

SCHEMA ELETTRICO - SHEMA ELECTRIQUE - WIRING DIAGRAM - SCHALTPLAN - ESQUEMA ELECTRICO

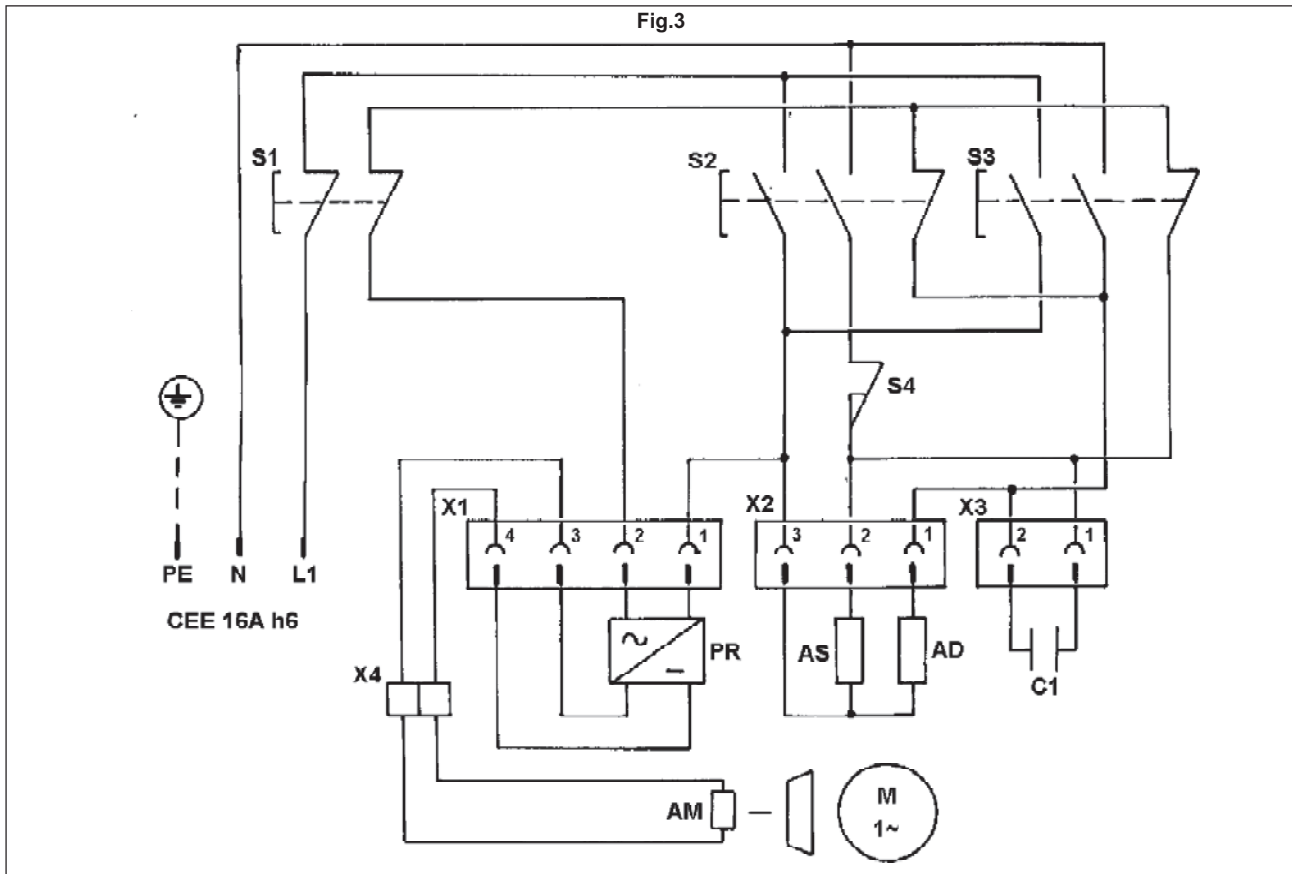

	<i>I</i>	<i>F</i>	<i>GB</i>	<i>D</i>	<i>E</i>
L1	CONDUTTORE LINEA	CONDUCTEUR DE LIGNE PHASE	PHASE WIRE	PHASENLEITER	CONDUCTOR DE LÍNEA FASE
N	CONDUTTORE LINEA NEUTRO	CONDUCTEUR DE LIGNE NEUTRE	NEUTRAL WIRE	MITTELLEITER	CONDUCTOR DE LÍNEA NEUTRO
PE	CONDUTTORE DI PROTEZIONE	CONDUCTEUR DE PROTECTION	EARTH WIRE	SCHUTZLEITER	CONDUCTOR DE LÍNEA PROTECCIÒN
S1	PULSANTE DI EMERGENZA	BOUTON-POUSSOIR D'URGENCE	EMERGENCY BUTTON	NOT-DRUCKSCHALTE	BOTÒN DE EMERGENCIA
S2	PULSANTE SALITA	BOUTON-POUSSOIR MONTEE	UP BUTTON	DRUCKSCHALTER HEBEN	BÒTON DE SUBIDA
S3	PULSANTE DISCESA	BOUTON-POUSSOIR DESCENTE	DOWN BUTTON	DRUCKSCHALTER HEBEN	BOTON DE BAJADA
S4	FINECORSA SALITA	FIN DE COURSE DESCENTE	DOWN SWITCH	ENDSCHALTER HUB	FINAL DE CARRERA SUBIDA
AS	AVVOLGIMENTO SALITA MOTORE	ENROULEMENT MOTEUR MONTEE	MOTOR WINDING, UP	MOTORWICKLUNG HUB	BOBINADO MOTOR SUBIDA
AD	AVVOLGIMENTO DISCESA MOTORE	ENROULEMENT MOTEUR DESCENTE	MOTOR WINDING, DOWN	MOTORWICKLUNG SENKEN	BOBINADO MOTOR BAJADA
AM	AVVOLGIMENTO MAGNETE FRENO	ENROULEMENT AIMANT FREIN	BRAKE MAGNET WINDING	WICKLUNG BREMSMAGNET	BOBINADO MAGNETO DEL FRENO
PR	ALIMENTATORE MAGNETE FRENO	ALIMENTATEUR AIMANT	BRAKE RECTIFIER	SPEISEGERÄT MAGNET	ALIMENTATOR MAGNETO
C1	CONDENSATORE	CONDENSEUR	CAPACITOR	KONDENSATOR	CONDENSADOR
X1	CONNETTORE ALIMENTAZIONE MAGNETE FRENO	CONNECTEUR ALIMENTATEUR AIMANT	BRAKE MAGNET CONNECTOR	VERBINDER MAGNET-SPEISEGERÄT	CONECTOR DEL ALIMENTADOR MAGNETO
X2	CONNETTORE MOTORE	CONNECTEUR MOTEUR	MOTOR CONNECTOR	MOTORVERBINDER	CONECTOR DEL MOTOR
X3	CONNETTORE CONDENSATORE	CONNECTEUR CONDENSATEUR	CAPACITOR CONNECTOR	KONDENSATOR VERBINDER	CONECTOR CONDENSADOR
X4	MORSETTI CONNESSIONE MAGNETE	BORNES AIMANT	MAGNET TERMINALS	KLEMMEN MAGNET	BORNES DEL MAGNETO

TAB.1				
Lunghezza cavo (m) / Longueur câble (m) / Cable length (m) / Kabel Länge (m) / Longitud cable (m)	0 ÷ 20	21 ÷ 35	36 ÷ 60	
sezione cavo (mm ²) / section câble (mm ²) / cable (mm ²) / kabel (mm ²) / cable (mm ²)	3x 1.5	2.5	4	