

FAR TOOLS



DM 300

Professional Machine

- FR** Outil multi fonctions (Notice originale)
- EN** Multi-function tool (Original manual translation)
- DE** Multifunktionswerkzeug (Originalbetriebsanleitung)
- ES** Herramienta multifuncional (Traducción del manual originale)
- IT** Utensile multifunzione (Traduzione dell'avvertenza originale)
- PT** Ferramenta multifuncional (Tradução do livro de instruções original)
- NL** Multifunctioneel gereedschap (Vertaling van de originele instructies)
- EL** Πολυλειτουργικό εργαλείο (Μετάφραση από τις πρωτότυπες οδηγίες)
- PL** Narzędzie wielofunkcyjne (Tłumaczenie z oryginalnej instrukcji)
- FI** Multifunksjonsverktøy (Käännös alkuperäisestä ohjeesta)
- SV** Multifunktionsverktyg (Översättning från originalinstruktioner)
- BU** Мулти-функционален електроинструмент (Превод на оригиналната инструкция)
- DA** Multifunktionsværktøj (Oversættelse fra oprindelige brugsanvisning)
- RO** Sculă electrică multifuncțională (Traducere din instrucțiunile originale)
- RU** Многофункциональный инструмент (Перевод с оригинальной инструкции)
- TU** Çok işlevli alet (Orijinal talimatlar çeviri)
- CS** Multifunkční nářadí (Překlad z originálního návodu)
- SK** Multifunkčné náradie (Preklad z originálneho návodu)
- HE** תיורוקמ תוארוהמ סוגרת) ממרטה רוטטת
- AR** (قي لصل آل تاميل عدل نم قم جردل) آلة صقل ارتج احيية
- HU** Többfunkciós szerszám (Fordítás az eredeti utasítások)
- SL** Multifunkcijsko orodje (Prevod iz izvornih navodil)
- ET** Multifunktsionaalne tööriist (Tõlge originaal juhiseid)
- LV** Daudzfunkciju instruments (Tulkojumā no instrukcijas oriģinālvalodā)
- LT** Daugiafunkcinis elektrinis įrankis (Vertimas iš originalių instrukcijas)



© FAR GROUP EUROPE

115145-A-20161107

www.fartools.com

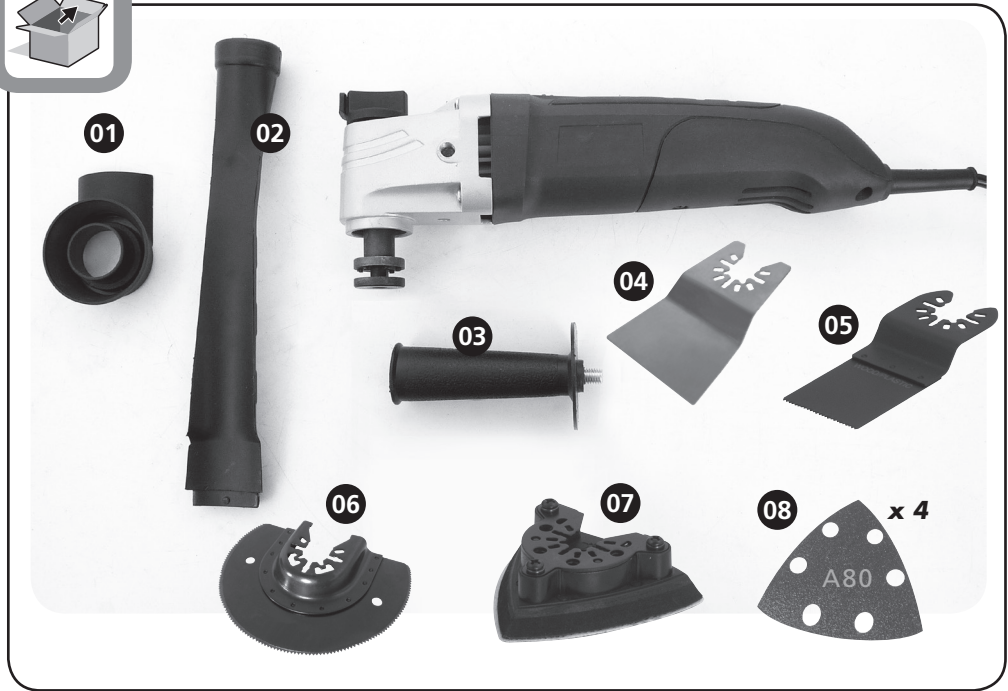

01

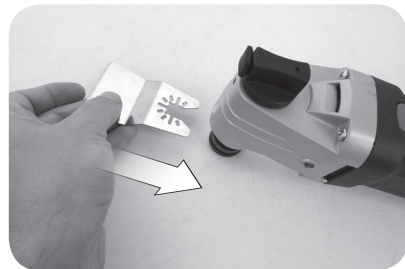
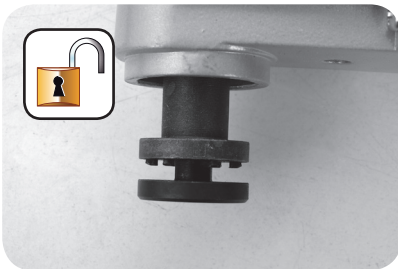
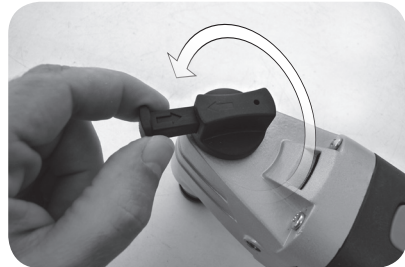
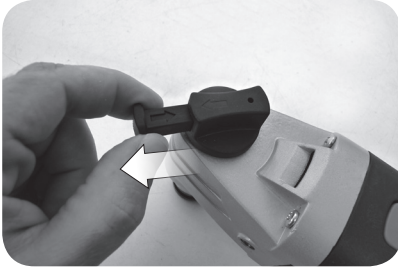



01

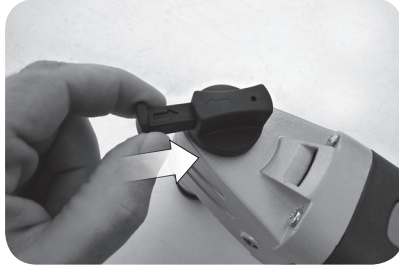
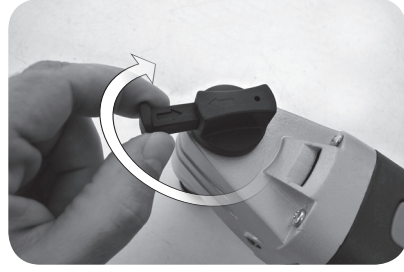

02

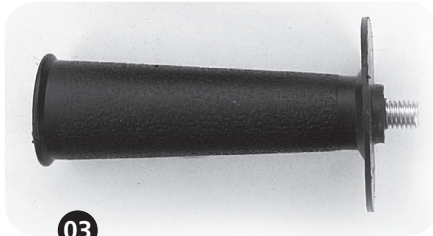

03





03

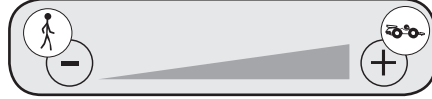
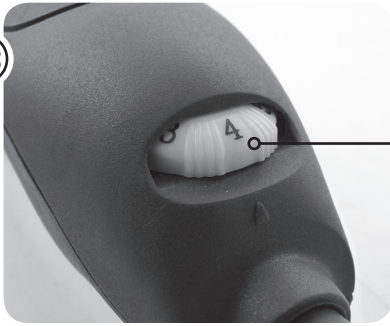

Variateur électronique
Elektronische regelaar
electrónica del inversor
electrónica inversor
Variador electrónico
Electronic variable speed

04

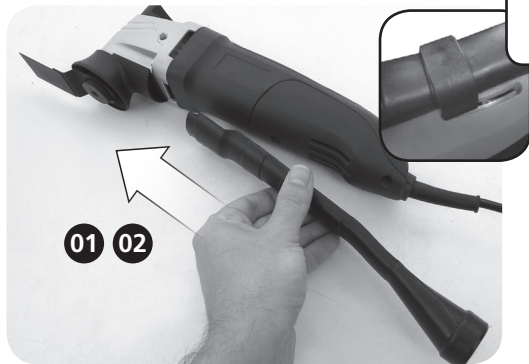
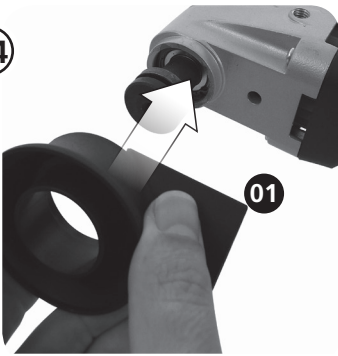

05



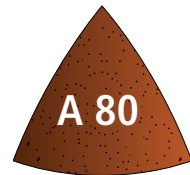
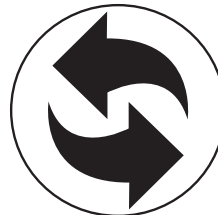

06





	<p>Tension et fréquence assignée: Nominal frequency and power: Spannung und Frequenz: Tensión y frecuencia fijada: Tensione e frequenza assegnata: Aangewezen spanning en frequentie: Ονομαστική τάση και συχνότητα: Napięcie i częstotliwość przydzielona: Jännite ja määrittäty taajuus: Angiven spänning och frekvens: Anført spænding og frekvens: Tensiune și frecvență de lucru:</p>	<p>Заданное напряжение и частота: Tahsis gerilimi ve frekansı: Stanovené napětí a frekvence: Stanovené napätie a frekvencia: מחמת ותדר מוקצב الغلطية والذبذبة المبرمجة. Névleges feszültség és frekvencia: Napetost in določena frekvenca: Консумирано напрежение и честота : Määratud pinge ja sagedus Nustatyta įtampa ir dažnis Noteiktais spriegums un frekvence.</p>	230 V ~ 50 Hz
---	--	---	----------------------

	<p>Puissance assignée: Nominal power: Leerlaufdrehzahl: Potencia fijada: Potenza assegnata: Potência assinada: Onbelast toerental: Ονομαστική ή ισχύς : Prędkość na biegu jałowym: Teho: Angiven effekt: Anført styrke: Putere de lucru:</p>	<p>Заданная мощность: Tahsis edilen güç: Stanovený příkon: Predpísaný výkon: כוח מוקצב. القدرة المبرمجة. Névleges teljesítmény : Določena jakost: Консумирана мощност: Määratud võimsus. Nustatyta galia Noteiktā jauda</p>	300 W
---	--	---	--------------

	<p>Vitesse à vide: No-load speed: Drehzahl unbelastet: Velocidad vacía: Velocità a vuoto: Velocidade no vácuo: Leerlaufdrehzahl: Ταχύτητα στο κενό: Prędkość bez bciążenia: Tyhjäkäyntinopeus Tomgångshastighet: Hastighed i ubelastet tilstand: Viteza în gol:</p>	<p>Скорость вращения на холостом ходу: Boşalma hızı: Rychlost naprázdno: Rýchlosť pri chode naprázdno: מהירות ריק. السرعة على الفارغ. Üres sebesség: Prosti tek: Скорост на празни обороти: Kiirus tühikäigul Tuščio prietaiso greitis Tukšgaitas ātrums</p>	1 5000-22000.min⁻¹
---	---	--	--------------------------------------

	<p>Poids : Weight : Gewicht : Peso : Peso : Peso : Gewicht : Βάρος : Masa : Paino : Vikt : Vægt : Greutate :</p>	<p>Вес : Ağırlık : Hmotnosť : Hmotnosť : משקל الوزن. Súly : Teža : Терло : Raskus Svoris Svars</p>	1,6 kg
---	--	---	---------------





	<p>Classe d'isolement : 2 Insulation class : 2 Isolierung klasse : 2 Aislamiento clase :2 Isolamento classe :2 Isolamento classe :2 Isolatie Klasse : 2 Εργαλειο τάξηζ : 2 Izolacja Klasy :2 Eristysluokka :2 Isolering Klass :2 Isoleringsklasse 2 Clasă izolație :2</p>	<p>Класс изоляции 2 : Yalıtım derecesi :2 Třída izolace :2 Izolačný systém 2 סוג בידוד 2 فية ال عزل 2 Szigetelési osztály :2 Razred izolacije :2 Инструмент Клас :2 Isolatsiooniklass 2 Izoliācijas rūšis 2 Izolācijas klase 2</p>	X
---	---	--	---

	<p>Conformité européenne Conforms to EC standards : CE-Konformität : Cumple con las directivas CE : Conforme alle norme CE : Conforme às normas CE : Voldoet aan de EG-normen : Συμφωνο με τα πρότυπα Zgodność z normami CE : EU-standardien mukainen : EU-standardien mukainen : Overholder EU standarderne : Conform cu normele europene:</p>	<p>соответствие европейским стандартам: Avrupa uygunluk : evropská shoda : európska dohoda : התאמה לתקנים האירופיים مطابق للمواصفات الأوروبية evropska ustreznost : európai megfeleléség : Съответствие с европейските норми : Euroopa Liidu vastavusmärk Europinių normų atitikima Atbilstība Eiropas standartiem</p>	X
---	---	--	---

	<p>Lire les instructions avant usage : Read the instructions before use : Vor Einsatz des Geräts Anweisung lesen : Léase las instrucciones antes de usar : Leggere le istruzioni prima dell'uso : Ler as instruções antes da utilização : Lees voor het gebruik de instructies : Διαβάστε τις οδηγίες χρήσης : Zapoznać się z instrukcją przed użyciem : Lue ohjeet ennen käyttöä : Läs anvisningarna före användning : læs instruktionerne før brug Înainte de utilizare, cititi instructiunile :</p>	<p>Внимательно прочитайте следующие инструкции : Kullanmadan talimatları okuyunuz : Pozorně si přečtete následující pokyny : Pred použitím si prečítajte pokyny : זרם חילופי اقرأ التعليمات قبل الاستخدام használat előtt olvassuk el az utasítást : Pred uporabo preberite ustrezna navodila : Прочетете указанията за употреба : Enne kasutamist lugege instruksiooni Prieš naudojimą perskaityti instrukciją izlasīt instrukcijas pirms lietošanas</p>	X
---	--	---	---

	<p>Danger : Danger : Gefahr : Peligro : Pericolo : Perigo : Gevaar : Κινδύος : Niebezpieczeństwo : Vaara : Fara : Fare : Pericol :</p>	<p>Опасно : Tehlike : Nebezpečí : Nebezpečnostvo : סכנה خطر Veszély : Nevamost: Опасност : Oht Pavojus Bīstamība</p>	X
---	--	--	---







	<p>Porter des lunettes de sécurité : Porter un masque anti-poussière: Porter une protection auditive:</p> <p>Wear protective eyewear : Wear a dust mask : Wear hearing protective equipment:</p> <p>Schutzbrille tragen : Staubschutzmaske tragen : Gehörschutz tragen:</p> <p>Llevar puestas gafas protectoras : Llevar puesta una careta de protección contra el polvo : Llevar puesta una protección auditiva:</p> <p>Portare de gli occhiali di sicurezza : Indossare una mascherina anti-polvere : Portare una protezione uditiva:</p> <p>Utilizar óculos de segurança : Utilizar uma máscara anti-poeira : Utilizar uma protecção auditiva:</p> <p>Draag een veiligheidsbril : Draag een stofmasker : Draag gehoorbeschermers:</p> <p>Φορέστε Προστατευτικά γυαλιά : χρήση προστατευτική μάσκα : Φορέστε Προστατευτικά ακουστικά</p> <p>Zakładać okulary ochronne : Zakładać maskę przeciwpyłową Zakładać słuchawki ochronne</p> <p>Käytä suojalaseja : Käytä pölysuojust : Käytä kuulosuojaimia:</p> <p>Använd skyddsglasögon : Bär mask mot damm : Bär hörselskydd:</p> <p>Der skal benyttes sikkerhedsbriller : Der skal benyttes beskyttelsesmaske mod støv: Der skal benyttes høreværn:</p> <p>Purtați ochelari de protecție : Purtați mască anti-praf : Purtați căști de protecție auz:</p>	<p>Наденьте защитные очки : Наденьте респиратор : наденьте средства звуковой защиты:</p> <p>Güvenlik gözlükleri takın : Toza karşı maske takın : İşitsel koruma aleti takın:</p> <p>Požívajte bezpečnostní brýle : Používejte masku proti prachu : Používejte ochranu sluchu:</p> <p>Noste ochrannú okuliare : Noste ochrannú masku proti prachu : Noste ochrannú slúchadlá:</p> <p>תוחיטב יפקשמ ביכרהל אן קבא דגנ הכסמ שובחל אן יש ל הרכיב הגנת שמיעה חמל נזחרות וקאי. ליבס קזא ע מוצאז ללדגבאר. ליבס חוזה צזש הצצגי. Viseljen védőszemüveget : Viseljen porvédő maszkot Viseljen fülvédőt</p> <p>Nositi zaščitna očala : Nositi zaščitno masko proti prahu: Nositi zašito ušes:</p> <p>Да се използват защитни очила : Да се използва защитна маска : Да се използват слухови защитни средства:</p> <p>Kandke kaitseprille Kandke tolmumaski. Kandke kõrvakaitset</p> <p>Nešioti apsauginius akinius Dėvėti respiratorių Nešioti apsaugą nuo triukšmo</p> <p>Valkät aizsargbrilles Valkät aizsarg masku pret putekljēm valkät dzirdes aizsarglīdzekli</p>
---	---	---

	<p>Porter des gants : Use rubber gloves : Schutzhandschuhe tragen : Llevar guantes de protección : Indossare i guanti di protezione : Utilizar luvas de protecção : Draag veiligheidshandschoenen : χρήση προστατευτικών γαντιών : Używać rękawic ochronnych : Käytä suojakäsineitä : Använd skyddshandskar : Der skal benyttes handsker : Purtați mănuși :</p>	<p>Наденьте перчатки : Eldiven takın : Noste rukavice : Noste rukavice : תופכ שובלל אן ליבס קזאזאז. Viseljen kesztyű t Nositi rokavice: a se използват предпазни ръкавици : Kandke kindaid Müvėti pirštines Valkät cimdus</p>
---	---	---





 L_{pA}	Niveau de pression acoustique : Acoustic pressure level : Schalldruckpegel : Nivel de presión acústica : Livello di pressione acustica : Nivel de pressão acústica : Niveau akoestische druk : Στάθμη Θορύβου : Poziom mocy akustycznej : Käytä kuulosuojaimia : Ljudtryksnivå : Lydtryk : Nivel presiune acustică :	Уровень акустического давления. : Akustik basınç seviyesi : Hladina akustického tlaku : Hladina akustického tlaku : רמת לחץ אקוסטי. مستوى الضغط السمعي. A hangnyomás szintje : Nivo akustičnega pritiska: Равнище на акустично налягане : Helirõhu nivoo Akustinio spaudimo lygis Akustiskā spiediena līmenis	84 dB (A)
--	--	--	------------------

 L_{wA}	Niveau de puissance acoustique : Acoustic power level : Schallleistungspegel : Nivel de potencia acústica : Livello di potenza acustica : Nivel de potência acústica : Niveau akoestisch vermogen : Στάθμη Ονομαστική Θορύβου : Poziom mocy akustycznej : Käytä suojalaseja : Ljudstyrkenivå : Lydstyrke : Nivel putere acustică :	уровень мощности звука : Akustik basınç seviyesi : Hladina zvukového výkonu : Hladina zvukového výkonu: רמת כוח אקוסטי. مستوى الخرجي. a hangnyomás szintje : Nivo akustične jakosti : Равнище на вибрации : Helivõimsuse nivoo Triukšmo lygis Akustiskās jaudas līmenis	95 dB (A)
--	--	---	------------------

NIVEAU SONORE D'EMISSION:

A VIDE

Pression acoustique LpA poste opérateur
Incertitude

84 dB
3

Puissance acoustique LWA
Incertitude

95 dB
3

Valeurs déterminées suivant le code d'essai de l'annexe B de la norme EN 61029-1 avec emploi des normes de base ISO 11201 et ISO 3744.

Les niveaux de pression acoustique obtenus in situ dépendent:

- Des niveaux réels de la machine considérées, en prenant en compte les incertitudes déclarées;
- Du local et de l'installation de la machine. Préférez une pièce dont l'acoustique est plus feutrée. Evitez les pièces vide à grande résonance. Placez vous auprès d'une fenêtre le cas échéant.
- Des outils montés, des pièces travaillées, des réglages choisis,...

 L_v	Niveau de vibration : Hand/arm vibration level : Vibrationspegel Hand/Arm : Nivel de vibración mano/brazo : Livello di vibrazione mano/braccio : Nivel de vibração mão/braço : Trillingsniveau hand/arm : Στάθμη κρα"οασμών : Poziom wibracji rózka/ramiów : Tärinätaso: Vibrationsnivå hand/arm : Vibrationsniveau : Nivel vibratii :	Уровень вибрации : Titreşim seviyesi : Úroveň vibrací : Hladina vibrácií : רמת תנודות مستوى الارتجاج. Vibrációs szint : Nivo vibracij : Равнище : Vibrācijas līmenis. Vibrācijas lygis Vibratsiooni nivo	3,55 m/s²
---	---	--	-----------------------------

VIBRATIONS:

Total des valeurs de vibration (somme vectorielle des trois directions) déterminée selon EN 60745:

a 3,55 m/s²
Incertitude K 1,5 m/s²

L'amplitude d'oscillation peut être utilisée comme valeur de comparaison d'outils électroportatifs.

Attention: Si l'outil électroportatif est utilisé pour d'autres applications, avec d'autres outils de travail, l'amplitude d'oscillation peut être différente.





DM 300

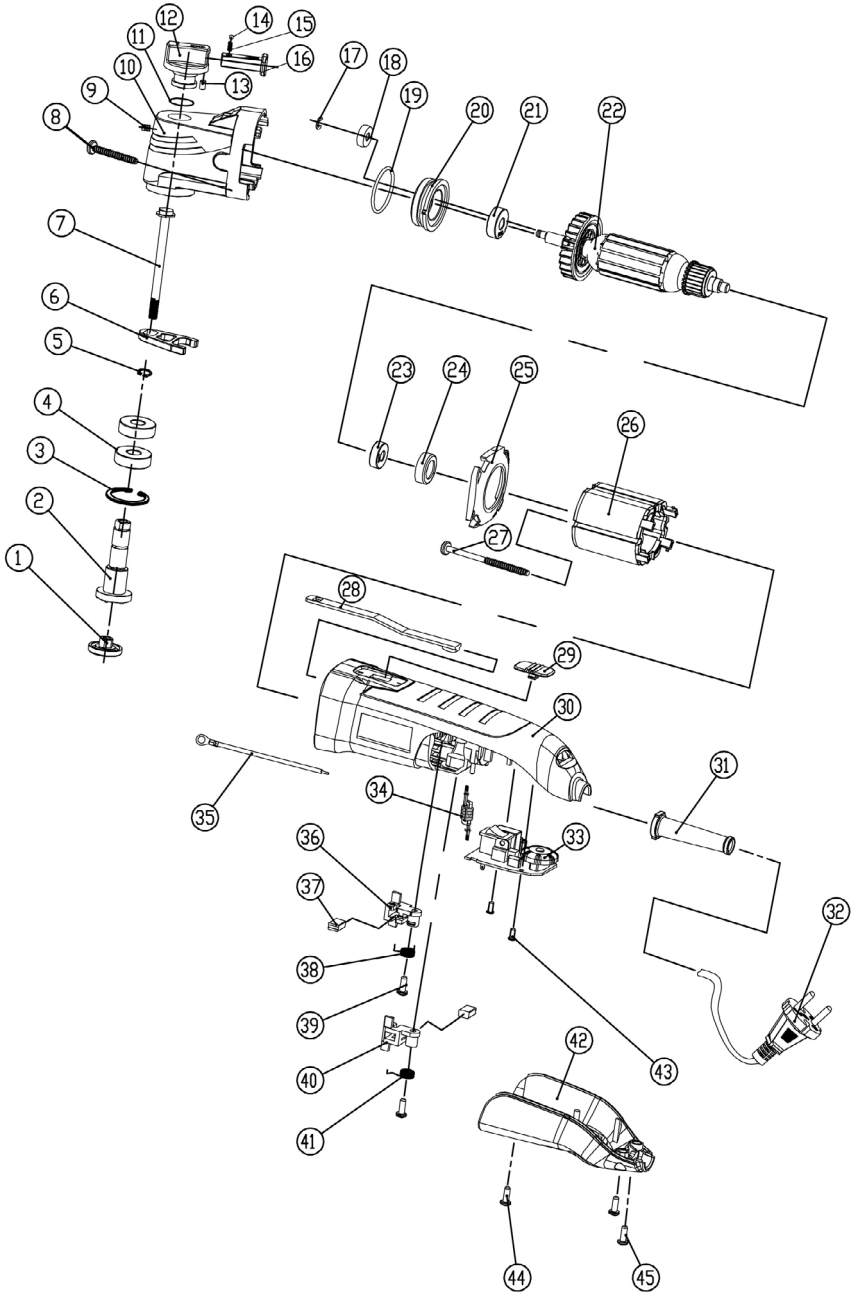



DECLARATION DE CONFORMITE
 VERKLARING VAN OVEREENSTEMMING
 DECLARACION DE CONFORMIDAD
 DICHIARAZIONE DI CONFORMITA
 KONFORMITÄSERKLÄRUNG
 DECLARAÇÃO DE CONFORMIDADE
 DEKLARACJA ZGODNOSCI Z NORMAMI
 OM ÖVERENSSTÄMMELSE
 VAATIMUSTENMUKAISUUSVAKUUTUS
 Overensstemmelseserklæring
 Δήλωση συμμόρφωσης/συμμόρφωσης

Declaratie de conformitate
 Vyhlasenie zhody
 הצהרת תאמת
 UYGUNLUK BEYANI
 التصريح بالطابق
 Prohlášení shody
 Egyezőségi nyilatkozat
 Декларация за съответствие с нормите
 Izjava o skladnosti
 DEKLARACIJA
 ΑΤΤΙΚΤΗΣ ΔΕΚΛΑΡΑCΙΑ
 KINNITUS

Le soussigné,
 Ondergetekende,
 Der Unterzeichner,
 O abaixo assinado,
 Undertecknad,
 Долуподписаният
 Undertegnede
 Subsemnatul,
 Я, нижеподписавшийся,
 Imzalayan,
 Niže podepsaný,
 Toliau pasirašęs

Personne autorisée à constituer
 le dossier technique :
 Christophe HUREL



FAR GROUP EUROPE
 192, Avenue Yves Farge
 37700 Saint-Pierre-des-Corps
 FRANCE

El suscrito,
 Il sottoscritto,
 The undersigned,
 Nínej podpisany
 Allekirjoittanut,
 Ουδτογεγραμμένος
 Nižšie podpisany
 הצהרת מתה
 الجوق ع أدناه
 Alulírott,
 Podpisani,
 Apakšā parakstijies
 allakirjutanut

Declaro por la presente que,
 Dichiare che,
 Declares that,
 OÖwiedzca niniejszym, że
 Ilmoittaan täten että,
 Δηλώνει με την Παράστα
 týmto vyhlasuje, že
 מצהיר בה כי
 یصدیح استنادا علی ذاك
 kijelentem, hogy a készülék Izjavlja da,
 Pareiškia, kad,
 Ar šo apliecina, ka,
 Kinnitat, et

Déclare par la présente que,
 Verklaart hiermede dat,
 Erklärt hiermit daß,
 Declara pela presente que,
 Förklarar härmed att
 Заявлява с настоящото
 erklærer hermed, at
 Declar prin prezenta că
 настоящим подтверждаю, что
 Mecvut belgeyle beyan edilyor ki,
 tímto prohlašuje, že,
 Pareiškia, kad,

**Outil multi fonctions / Multi-function tool / Multifunktionswerkzeug / Herramienta multifuncional /
 Utensile multifunzione / Ferramenta multifuncional / Multifunctioneel gereedschap / Πολυλεειτουργικό εργαλείο /
 Narzędzie wielofunkcyjne / Multifunktionsværktøj / Multifunktionsverktøy / Мульти-функционален електроинструмент /
 Multifunktionsværktøj / Sculă electrică multifuncțională / Мультифункциональный инструмент / Cok islevisli alet / Multifunkční nářadí /
 Multifunkčné náradie / מטרות רבטות / آلة حرقول ارتجاجة / Többfunkciós szerszám / Multifunkcijsko orodje /
 Multifunktsionaalne tööriist / Daudzfunkciju instruments / DAUGIAFUNKCINIS ELEKTRINIS IRANKIS**

code

FARTOOLS / 115145 / DM 300 / LD2906

Est conforme et satisfait aux directives et normes CE,
 In overeenstemming si met en Voldoet aan EG richtlijnen,
 Den folgenden EU-Bestimmungen entspricht,
 Respeita e está em conformidade com as normas CE,
 Överensstämmer med och uppfyller EG-standarder,
 Съответства и отговаря европейските норми
 er i overensstemmelse med og overholder EU standarderne
 Este conform și satisface normele CE
 полностью соответствует и удовлетворяет
 требованиям стандартов ЕС
 CE şartlara uygundur,
 odpovídá normám ES,
 Atitinka ir atitinka EB direktyvas ir standartus,

Cumple con la directivas de la CE,
 E conforme alle direttive CEE,
 Complies with the EEC directives and standards,
 Odpowiada normom UE,
 Täyttää EU-vaatimukset,
 Είναι σύμμορφων και ανταποκρίεται στα Παράστα CE
 zodpovedá normám ES,
 מתאים ועונה לתקני CE
 بان الحدان يطابق ويلبي م مجموعة الدول الأوروبية
 kielégíti a CE szabványok előírásait.
 Je v skladu z in izpolnjuje norme Evropske skupnosti.
 Atbilst un atbilst EK direktīvas un standartus,
 Vastab ja vastab EU direktīvidele ja standartitele,

EMC: 2014/30/EU MD: 2006/42/EC RoHS:2011/65/EU

EN60745-1:2009 +A11:2010
 EN60745-2-4:2009+A11:2011
 EN ISO12100:2010 EK9-BE-88:2014
 EN55014-1:2017
 EN55014-2:2015
 EN61000-3-2:2014
 EN61000-3-3:2013

Christophe HUREL,
 Président Directeur Général
 07/03/2018
 Fait à Saint-Pierre-des-Corps





Plaques signalétiques - naamplaatjes - placas de identificación - placas de identificação - targhette - machine labels

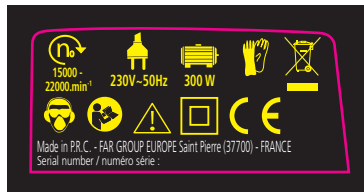



FR. GARANTIE

Cet outil est garanti contractuellement contre tout vice de construction et de matière, à compter de la date de vente à l'utilisateur et sur simple présentation du ticket de caisse. La garantie consiste à remplacer les parties défectueuses. Cette garantie n'est pas applicable en cas d'exploitation non conforme aux normes de l'appareil, ni en cas de dommages causés par des interventions non autorisées ou par négligence de la part de l'acheteur. La garantie ne s'applique pas sur les dommages causés par une défaillance de l'outil.

DE. GARANTIE

Die Garantiezeit für dieses Gerät in bezug auf Konstruktions- und Materialfehler beträgt lt. Vertrag bei Vorlage des Kassensbons. Die Garantieleistung besteht im Ersatz schadhafter Teile. Die Garantie erlischt bei einem Einsatz des Geräts, der nicht normentsprechend ist, bei Schäden, die auf unsachgemäße Eingriffe zurückzuführen sind bzw. bei Nachlässigkeit seitens des Käufers. Die Garantie erstreckt sich nicht auf Schäden, die auf Fehlfunktionen des Geräts zurückzuführen sind.

IT. GARANZIA

Quest' attrezzo è garantito per contratto contro qualsiasi difetto di costruzione e di materia, a partire dalla data di vendita all' utente e su semplice presentazione dello scontrino. La garanzia consiste nel sostituire le parti difettose. Questa garanzia non è applicabile in caso di sfruttamento non conforme alle norme dell' apparecchio, né in caso di danni causati da interventi non autorizzati o da negligenza da parte dell' acquirente. La garanzia non si applica ai danni causati da un' avaria dell' attrezzo.

EN. GARANTEE

This tool is guaranteed, in writing, against any defect in manufacture or parts from the date of sale, upon simple presentation of the sales slip. The guarantee is limited to the replacement of faulty parts. This guarantee is not applicable in the event of usage which is not conform with the intended usage of the apparatus, nor in the event of damage caused by unauthorised servicing or negligence on behalf of the purchaser. This guarantee does not apply to any damage caused by the failure of this tool.

ES. GARANTIA

Esta herramienta se garantiza contractualmente contra todo defecto de construcción y materia, a partir de la fecha de venta a l' usuario y sobre simple presentación del recibo de caja. La garantía consiste en sustituir a las partes defectuosas. Esta garantía no es aplicable en caso de explotación no conforme a las normas del aparato, ni en caso de daños causados por intervenciones no autorizadas o por negligencia por parte del comprador. La garantía no se aplica sobre los daños causados por un fallo del herramienta.

NL. GARANTIE

Dit gereedschap heeft een garantie tegen constructiefouten en materiaaldefecten, die geldig is vanaf de aankoopdatum door de gebruiker, op vertoning van de kassabon. De garantie betreft de vervanging van de defecte onderdelen. Deze garantie is niet van toepassing indien het apparaat niet volgens de normen gebruikt is, noch in geval van schade veroorzaakt door oneigenlijk gebruik of nalatigheid van de koper. De garantie is niet van toepassing op schade voortvloeiend uit een defect van het gereedschap.

PT. GARANTIA

Esta ferramenta tem uma garantia contratual contra qualquer defeito de construção e de material, a partir da data de venda ao utilizador e sobre simples apresentação do talão da caixa.. A garantia consiste em substituir as partes defeituosas. Esta garantia não é aplicável no caso de exploração não conforme às normas do aparelho, nem em caso de danos causados pelas intervenções não autorizadas ou por negligência da parte do comprador. A garantia não se aplica para os danos causados por uma falha da ferramenta.

EL. Εγγύηση

Το εργαλείο αυτό φέρει συμβατική εγγύηση για οποιoδήποτε ελάττωμα κατασκευής απ'ο την ημερομηνία Π'ωλησης στο χρώστη. με απλή Προσκόμιση της απ'ο'οείξης αγοράς. Η εγγύηση αποτελείται απ'ο την αντικατάσταση των ελαττωματικών τμημάτων. Η Παρούσα εγγύηση οεν εφαρμόζεται σε περίπτωση χρήσης μη σύμφωνα με τα Πρόστυπα της συσκευής. η σε περίπτωση ζημιών που Προκλήθηκε απ'ο μη εγκκερμ'ενη επέμβαση ή απ'ο αμ'είλεια του αγοραστή. Η εγγύηση "οεν εφαρμόζεται στις ζημιές που Προκαλούνται απ'ο βλάβη του εργαλείου Σταυρού κενού Διασπασμο-Παρέμυσμα

PL. GWARANCJA

Narz'dzie jest obj'ete gwarancją na wszelkie wady konstrukcyjne i materiałowe, licząc od daty sprzed'any u'ytownikowi i po okazaniu paragonu kasowego. Gwarancją obejmuje wymian' cz'łci wybrakowanych. Gwarancją nie znajduje zastosowania w przypadku u'ytowania niezgodnego z normami urz'adzenia, ani w przypadku szkód spowodowanych działaniami niedozwolonymi lub zaniebaniami ze strony nabywcy. Gwarancją nie obejmuje szkód powstałych z powodu upadku urz'adzenia.

SV. GARANTI

Detta verktyg har en avtalsenlig garanti mot konstruktions- och materialfel, från och med tidpunkten för användarens inköp och genom uppvissning av kassakvittot. Garantin består i att ersätta de bristfälliga delarna. Denna garanti gäller inte om användningen inte motsvarar apparatens standarder, inte heller vid skador som orsakas av ej tillåtna ingrepp eller på grund av köparens vårdslöshet. Garantin gäller inte förskador som orsakats av att verktyget fungerat bristfälligt.

FI. TAKUU

Tämän laitteen takuu on voimassa sopimuksenmukaisesti kattaa kaikki rakenne- ja materiaaliiviat lukien ostopäivästä kassakuittia vastaan. Takuu sisältää viallisten osien korvaamisen. Takuu ei korvaa ohjeidenvastaista käyttöä eikä valtuuttamattomien henkilöiden käsittelystä tai ostajan huolimattomuudesta aiheutuneita vahinkoja. Takuu ei vastaa myöskään toimintahäiriöistä aiheutuneita vahinkoja.

BU. Гаранция

Този инструмент е под договорна гаранция срещу всякакъв дефект в изработката и използваните материали, считано от датата на продажба на потребителя и само срещу представяне на касовата бележка. Гаранционното обслужване се състои в замяна на дефектните части. Настоящата гаранция не е валидна когато апаратът се използва по начин, несъответстващ на стандарта за работа с него, както и в случай на щети, нанесени от неоторизирани лица, или вследствие на проявена небрежност от страна потребителя.

Гаранцията не покрива щети, произтекли вследствие на техническа неизправност на апарата.





DA. GARANTI

Dette værktøj er dækket af en garantikontrakt for konstruktions- og materialefejl, som gælder fra købsdatoen ved visning af kassebonen. Garantien består i at udskifte de defekte dele. Garantien dækker ikke fejl opstået som følge af anvendelse, som ikke overholder standarderne for apparatet, eller skader opstået ved ikke autoriserede indgreb eller sløsethed fra brugerens side. Garantien dækker ikke skader opstået, fordi værktøjet har svigtet.

RO. GARANȚIE

Acest aparat este garantat din punct de vedere contractual împotriva tuturor viciilor de construcție și de material, începând de la data vânzării lui către utilizator și la simpla prezentare a bonului de casă. Garanția constă în înlocuirea componentelor defecte. Această garanție nu se aplică în cazul exploataării în alt mod decât cel recomandat de normele aparatului și nici în caz de stricăciuni provocate de intervenții neautorizate sau prin neglijența cumpărătorului. Garanția nu se aplică asupra pagbelor cauzate de o defectare a aparatului.

RU. ГАРАНТИЯ

Данное изделие обладает имеющей силу контракта гарантией, покрывающей все возможные дефекты изготовления и материала. Гарантия вступает в силу с даты продажи изделия пользователю, для этого достаточно сохранить и предъявить полученный в кассе чек. Гарантия обязывает изготовителя заменить дефектные части изделия. В случае не соответствующего нормам использования изделия, несанкционированного демонтажа или ремонта или небрежного обращения действие гарантии прекращается. Гарантия не покрывает ущерба, возникшего в результате сбоев в работе изделия.

TU. GARANTI

Bu araç, satış tarihinden itibaren, kullanıcının sadece vezne alındısını summasıyla tüm üretim ve malzeme hatasına karşı garantilidir. Garanti eksik olan kısımları değiştirmek içindir. Bu garanti aracın şartlarına uygun olmayan işleme durumunda, izin verilmeyen kullanımlardan kaynaklanan hasarlarda veya alıcının isteği durumunda uygulanmaz. Garanti malzemenin bir eksikliğinden meydana gelen bir zararda uygulanmaz.

CS. ZÁRUKA

Pro tento nástroj platí smluvní záruka na všechny výrobní a materiálové vady od data prodeje uživateli a na základě předložení pokladního bloku. Záruka spočívá ve výměně vadných částí. Tato záruka neplatí v případě použití přístroje, které neodpovídá normám, ani v případě škod způsobených nepovolenými zásahy nebo nedbalostí ze strany kupujícího. Záruka se nevztahuje na škody způsobené závadou nástroja.

SK. ZÁRUKA

Pre tento nástroj platí zmluvná záruka na všetky výrobné a materiálové chyby od dátumu predaja užívateľovi a na základe predloženia pokladničného bloku. Záruka spočíva vo výmene chybných častí. Táto záruka neplatí v prípade použitia prístroja, ktoré nezodpovedá normám, ani v prípade škôd spôsobených nepovolenými zásahmi alebo nedbalosťou zo strany kupujúceho. Záruka sa nevzťahuje na škody spôsobené poruchou nástroja.

HE. אחריות

הי עלכלי זה חלה אחריות לפי חוזה מופני כל ליקוי בייצור או בחומר, החל מיום המכירה למשתמש עם הצגת חשבונית קופה. האחריות-משמעה החלף תחלקם הלקויים אחריות זו אינה חלה במקרה של שימוש במכשיר שאינו מתאים לתקנים ובמקרה של נזק שנגרם על ידי התערבות תלל סמכות או על ידי רשלנות מאת הקונה. האחריות אינה חלה על נזק שנגרם על ידי תקלה בכלי.

AR. الضمان

دة مضمونة تأقديا من أي عيب في التصني عوفسي الجواء، إعتبارا من تاريخ البيع إلى المستعمل وبنابا على مجرد تقديم بطاقة الشراء، يتعل ق الأجزاء العاطلة لا يكون هذا الضمان قابلا للتطبيق في حالة الأستخدام غير المطابق لمعايير الجهاز، ولا في حالة تعرضه لتألفات إن هذه الع ناتجة عن عمليات تدل غير مخصصة أو في حالة الإهمال من قبل المشتري لا ينطبق الضمان على الخرد الناتج عن غل الضمان فباي سبدال

HU. GARANCIA

Erre a szerszámra szerződéses garanciát vállalunk bármilyen gyártási és anyaghiba felmerülése esetére, a fogyasztó részére történt eladás napjától számítva, a pénztári blokk egyszerű felmutatása ellenében. A garancia a hibás alkatrészek cseréjére terjed ki. Ez a garancia nem érvényes, ha a készüléket nem rendeltetésszerűen használták, sem illetéktelen beavatkozások, vagy a vásárló hanyagsága okozta károk esetén. A garancia nem fedezi azokat a károkat, melyeket a szerszám hibás működése okozott.

SL. GARANCIJA

To orodje je z garancijsko pogodbo zaščiteno proti vsem napakam v izdelavi in v sestavnem materialu od datuma prodaje naprej in ta velja ob predložitvi blagajniškega računa . Garancija velja za zamenjavo delov z napako. Ta garancija ne velja za uporabo orodja, ki ni v skladu z normami, predpisanimi za omenjeno orodje in za primere okvar, ki nastanejo zaradi nedovoljenih posegov na orodju ali zaradi malomarnega rokovanja kupca. Garancija ne velja za škodo, ki jo lahko povzroči okvara orodja.

ET. GARANTII :

See tööriist kuulub lepingu järgi garantiiremonti arvestades alates müümise päevast ja kasatšeki alusel kasutatjale kõigi konstrukt-siooni- ja materjalvigade puhul. Garantii seisneb defektsete osade väljavahetamises. See garantii ei kehti aparadi normide eba-tavalise eiramise puhul ega ostja poolt keelatud viisil kasutamises või hooletussejätmisest tulenevate kahjude korral. Garantii ei kehti seadme defektidest põhjustatud kahjude puhul

LV. GARANTIJA :

Šis prietaisais yra užtikrinamas kaip itin geros kokybės, nuo jo pardavimo datos iki jo panaudojimo, ir jam yra suteikiamas garantinis talonas. Garantijos metu galima pakeisti atsiradusius trumplataikius gedimus. Ši garantija netaikoma esant netinkamam naudojimui ar nesilaikant reikiam šio aparato vartojimo instrukcijų, tai pat pačiam pirkėjui jį sugadinus. Garantija taip pat netaikoma, prietaisą naudojant ne pagal paskirtį ir jį apgadinus

LT. GARANTIJA :

Šim darbarikam ir liğumà noteikta garantija visiem defektiem, kas saistàs ar konstrukciju un materiàlu, sàkot ar pàrdošanas datumu, kad mašinu pàrdo lietotàjam un vienkàrši uzràdot kases àeku. Garantija ieklauj bojàto daļu nomaiņu. Ši garantija nav derīga, ja aparàts nav lietots saskaņà ar drošibas noteikumiem, ne gadījumos ja bojājumi radušies nesankcionētās iejaukšanās gadījumā vai arī pircēja nolaidības dēļ. Garantija nav derīga , ja bojājumi radušies darbarika defekta dēļ

