

# FAR TOOLS®



## MS 3625

Professional Machine

© FAR GROUP EUROPE

113770-C-20150519



- FR** *Mortaiseuse ( Notice originale )*
- EN** *Mortiser ( Original manual translation )*
- DE** *Stemmmaschine (Originalbetriebsanleitung)*
- ES** *Mortajadora ( Traducción del manual originale )*
- IT** *Mortasatrice ( Traduzione dell'avvertenza originale )*
- PT** *Escatelador ( Tradução do livro de instruções original )*
- NL** *Steekbank ( Vertaling van de originele instructies )*
- EL** ΜΗΧΑΝΗ ΔΙΑΤΡΗΣΗΣ ( Μετάφραση από τις πρωτότυπες οδηγίες )
- PL** ΔΕΥΤΑΡΚΑ ( Tłumaczenie z oryginalnej instrukcji )
- FI** *Pistoajursinkone ( Käännös alkuperäisestä ohjeet )*
- SV** *Stickmaskin ( Översättning från originalinstruktioner )*
- BU** ДЪЛБАЧНА МАШИНА ( Превод на оригиналната инструкция )
- DA** *Taphulsmaskine ( Oversættelse fra oprindelige brugsanvisning )*
- RO** MAȘINĂ DE MORTEZAT ( Traducere din instrucțiunile originale )
- RU** ДОЛБЁЖНЫЙ СТАНОК (Перевод с оригинальной инструкции)
- TU** PLANYA MAKINESİ ( Orijinal talimatlar çeviri )
- CS** SVISLÝ OBRÁŽECÍ STROJ ( Překlad z originálního návodu )
- SK** DLABAČKA (Preklad z originálneho návodu)
- HE** תוירוקמ תוארוהמ סוגרת) ע דוביעל הצרמח
- AR** قة لصلأا تامي لعتلا نم قم جرتلا) بشغلا قراون
- HU** CSAPLYUKVÉSŐ GÉP ( Fordítás az eredeti utasítások )
- SL** VERIŽNI REZKAR (Prevod iz izvornih navodil)
- ET** TAPIFREES (Tõlge originaal juhiseid)
- LV** GROPĒTĀJS (Tulkojumā no instrukcijas oriģinālvalodā)
- LT** SUJUNGIMO LIZDŲ SKOBTUVAS (Vertimas iš originalių instrukcijas)

[www.fartools.com](http://www.fartools.com)

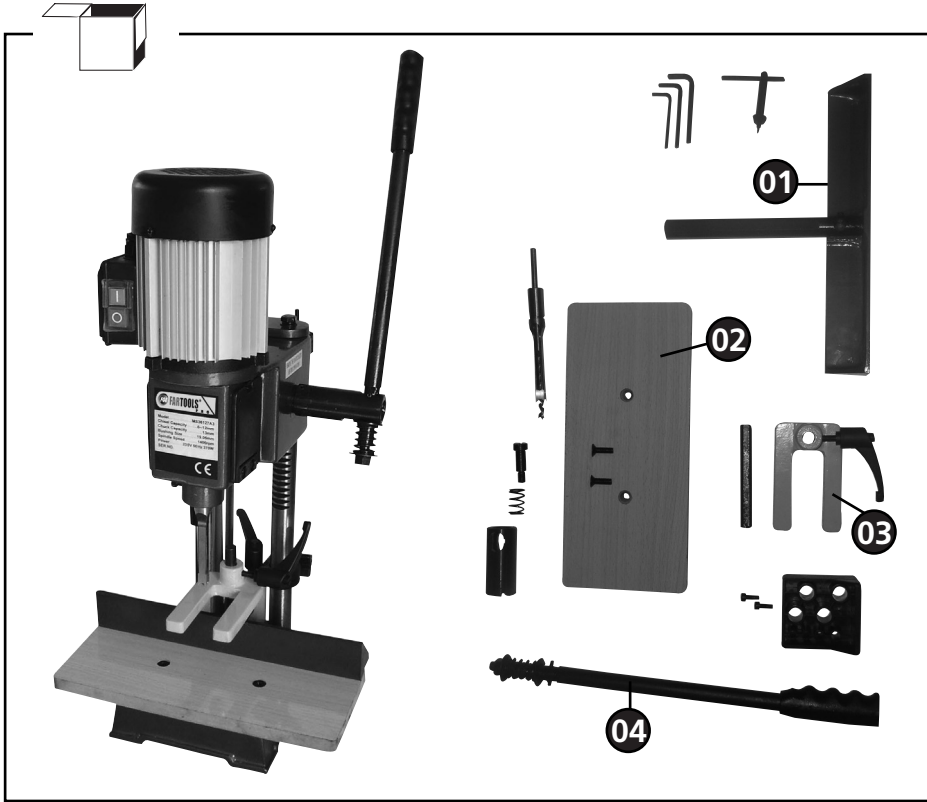

01

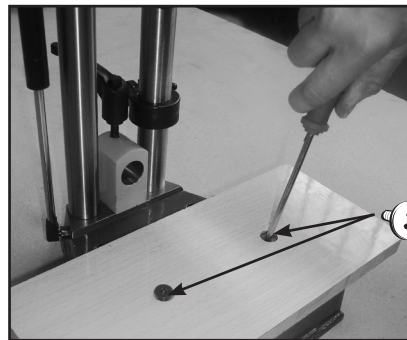
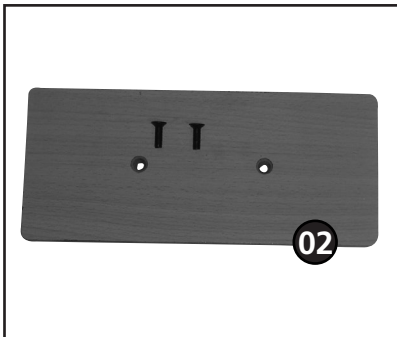
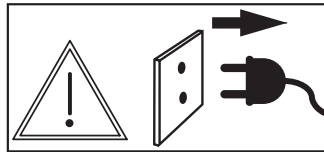



02



01

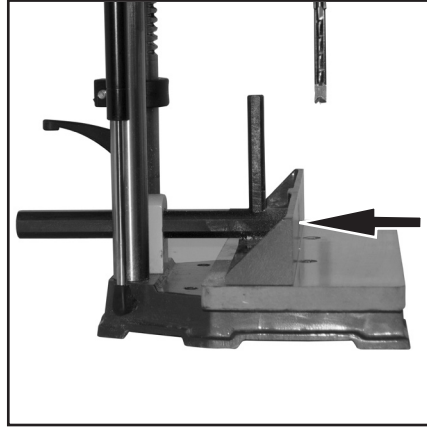

03



03

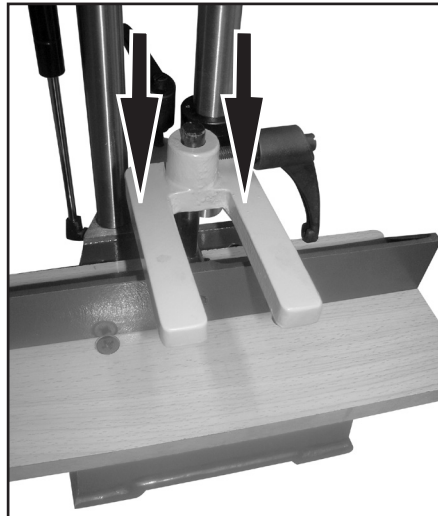
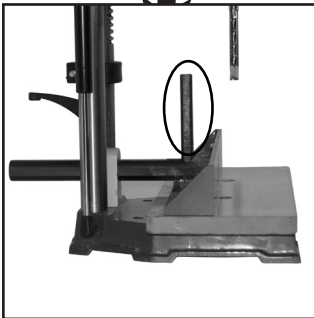



04

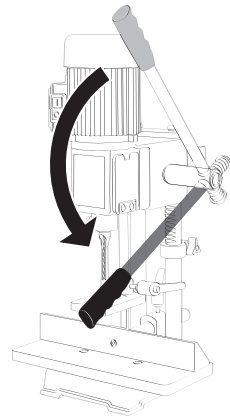
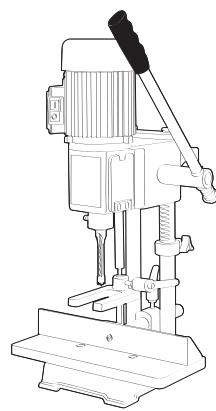
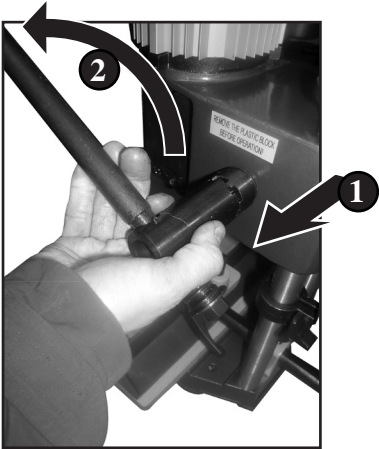
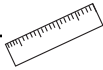
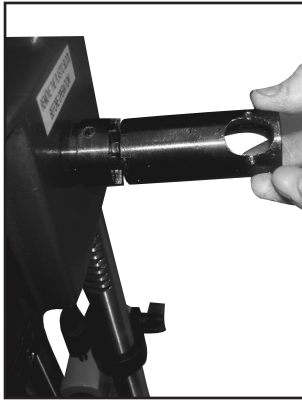
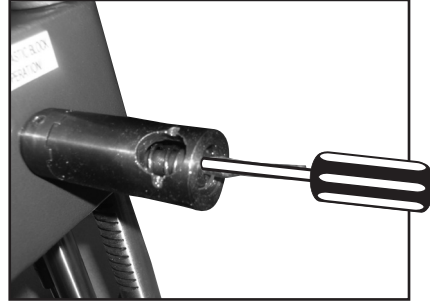
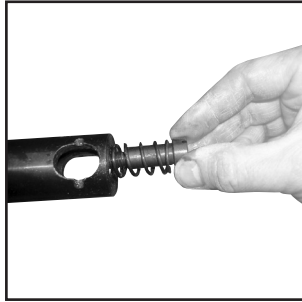



05

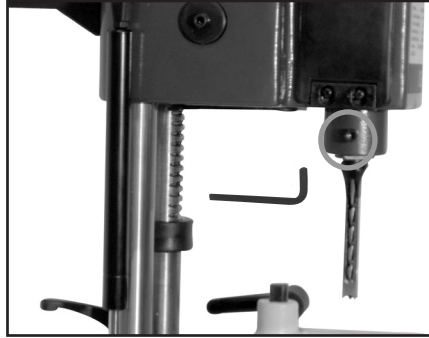
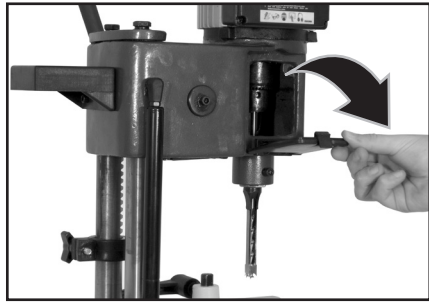
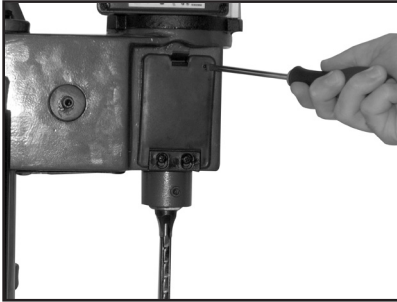

06

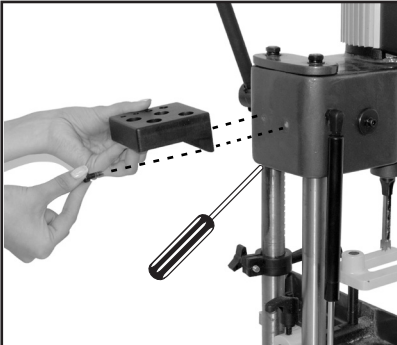



01

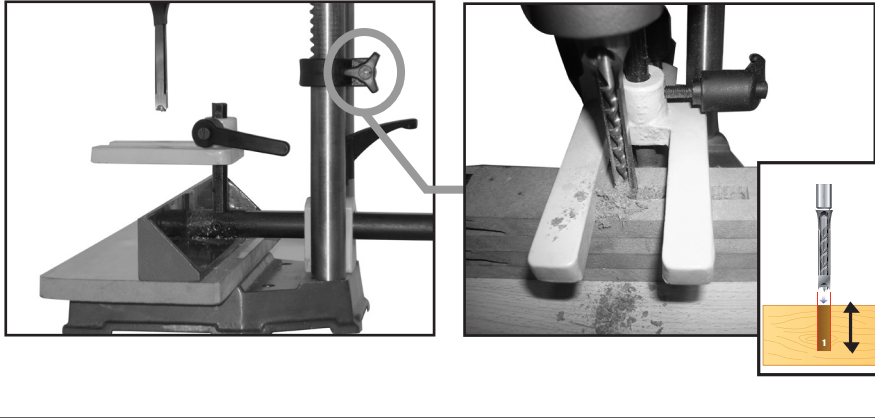

02

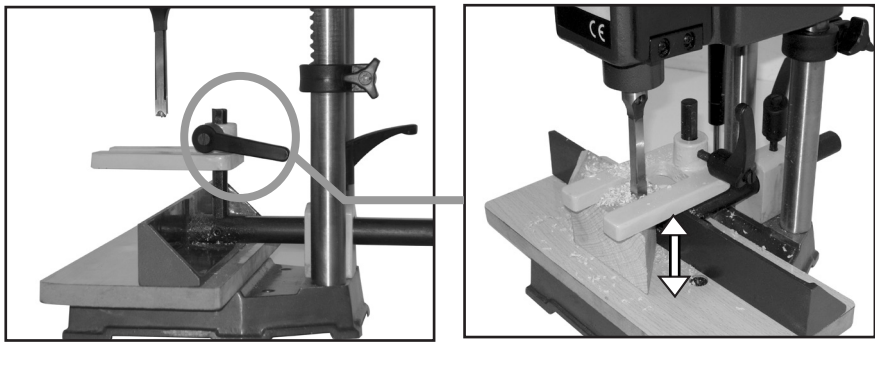

03

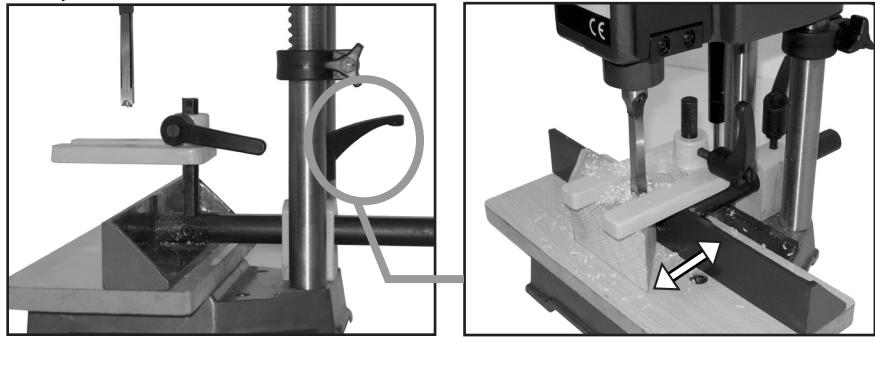



04



2 mm

03

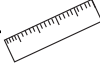

1

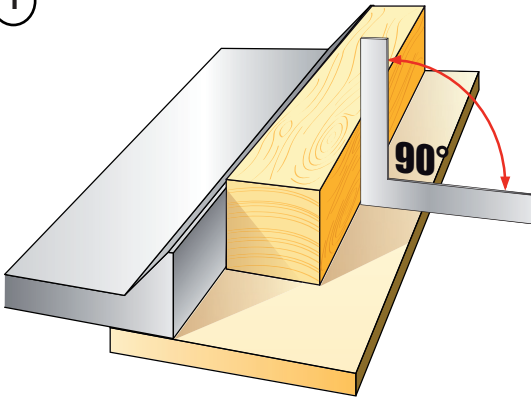

2

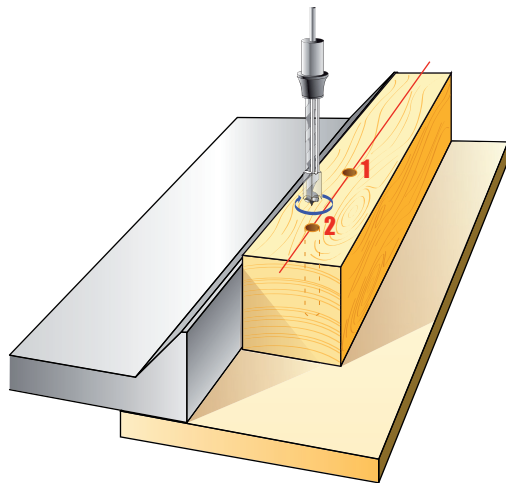
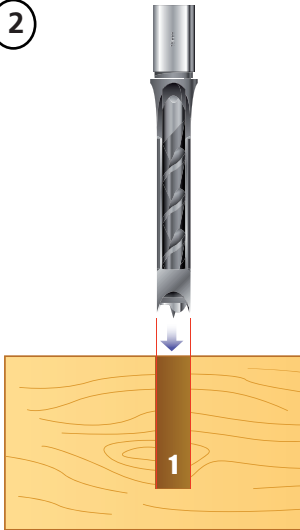

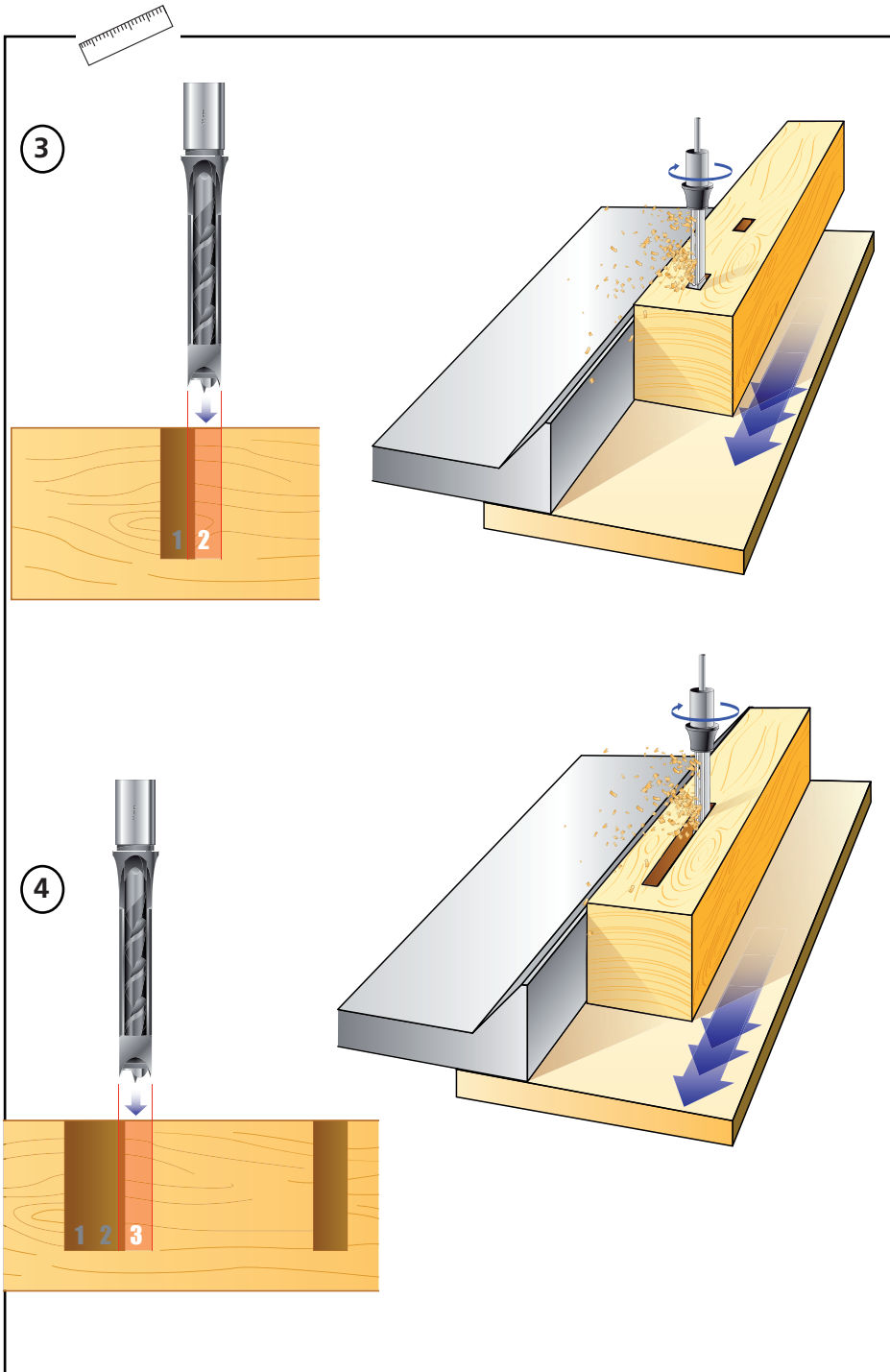



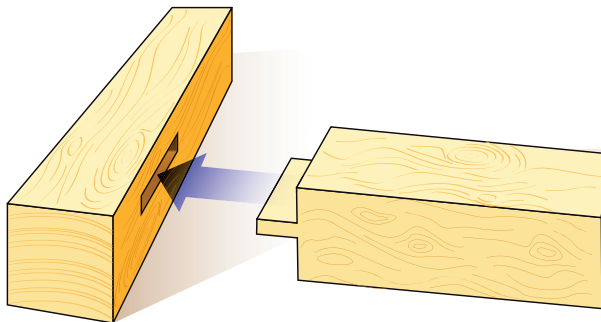
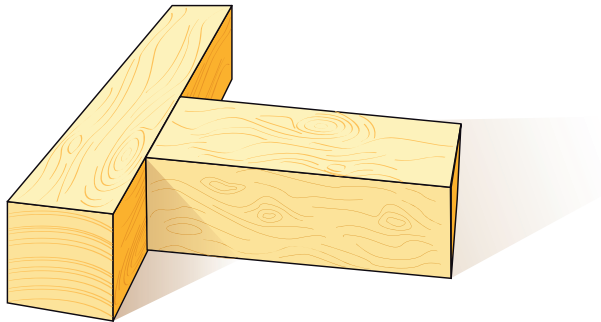
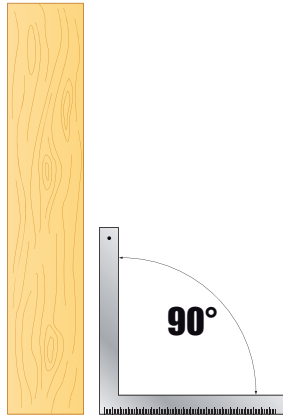







	<p>Tension et fréquence assignée: Nominal frequency and power: Spannung und Frequenz: Tensiön y frecuencia fijada: Tensione e frequenza assegnata: Tensão e frequência fixa: Aangewezen spanning en frequentie: Ονομαστική τάση και συχνότητα: Napięcie i częstotliwość przydzielona: Jännite ja määrittäy taajuus: Angiven spänning och frekvens: Anført spænding og frekvens: Tensiune și frecvență de lucru:</p>	<p><b>Заданное напряжение и частота:</b> Tahsis gerilimi ve frekansı: Stanovené napětí a frekvence: Stanovené napätie a frekvencia: בצקומ דתתו חתמת تجھربملا قېذبذلاو قېظلفلا Névleges feszültség és frekvencia: Napetost in določena frekvenca: <b>Консумирано напрежение и честота :</b> <b>Määratud pinge ja sagedus</b> Nustatyta įtampa ir dažnis <b>Noteiktais spriegums un frekvence.</b></p>	<p>230 V ~ 50 Hz</p>
---	---	--	----------------------

	<p>Puissance assignée: Nominal power: Leerlaufdrehzahl: Potencia fijada: Potenza assegnata: Potência assinada: Onbelast toerental: Ονομαστική ισχύς : Prędkość na biegu jałowym: Teho: Angiven effekt: Anført styrke: Putere de lucru:</p>	<p><b>Заданная мощность:</b> Tahsis edilen güç: Stanovený příkon: Predpísaný výkon: בצקומ חזק تجھربملا قېدوللا Névleges teljesítmény: Določena jakost: <b>Консумирана мощност:</b> <b>Määratud võimsus.</b> Nustatyta galia <b>Noteiktā jauda</b></p>	<p>370 W</p>
---	--	---	--------------

	<p>Vitesse à vide: No-load speed: Drehzahl unbelastet: Velocidad vacía: Velocità a vuoto: Velocidade no vácuo: Leerlaufdrehzahl: Ταχύτητα στο κενό: Prędkość bez obciążenia: Nopeus tyhjillään: Tomgångshastighet: Hastighed i ubelastet tilstand: Viteza în gol:</p>	<p><b>Скорость вращения на холостом ходу:</b> Boşalma hızı: Rychlost naprázdno: Rýchlost' pri chode naprázdno: קיר תוריהמ غزافلا ىلع ةعرسللا Üres sebesség: Prosti tek: <b>Скорост на празни обороти:</b> <b>Kiirus tühikäigul</b> <b>Tuščio prietaiso greitis</b> <b>Tukšgaitas ātrums</b></p>	<p>1400 min<sup>-1</sup></p>
---	---	---	------------------------------

	<p>Poids : Weight : Gewicht : Peso : Peso : Peso : Gewicht : Βάρος : Masa : Käytä suojakäsineitä : Vikt : Vægt : Greutate :</p>	<p><b>Вес :</b> Ağırlık : Hmotnost : Hmotnost' : לקשמ نزلولا Súly : Teža : <b>Тегло :</b> <b>Raskus</b> <b>Svoris</b> <b>Svars</b></p>	<p>24,5 kg</p>
---	---	--	----------------

		<p>76 mm</p>
---	--	--------------

		<p>X</p>
---	--	----------





	<p>Porter des lunettes de sécurité : Wear protective eyewear : Schutzbrille tragen : Llevar puestas gafas protectoras : Portare de gli occhiali di sicurezza : Utilizar óculos de segurança : Draag een veiligheidsbril : Φορέστε Προστατευτικά γυαλιά : Zakładać okulary ochronne : Käytä suoja-laseja : Använd skyddsglasögon : Der skal benyttes sikkerhedsbriller : Purtati ochelari de protecție :</p>	<p><b>Наденьте защитные очки :</b> Güvenlik gözlükleri takın : Používejte bezpečnostní brýle : Noste ochranné okuliare : תוהיטב יפקשמ ביכרהל אנ חמל נזלרות וקאי.ة. Viseljen védőszemüveget : Nositi zaščitna očala : <b>Да се използват защитни очила :</b> Kandke kaitseprille Nešioti apsauginius akinius Valkät aizsargbrilles</p>	X
---	---	---	---

	<p>Porter un masque anti-poussière: Wear a dust mask : Staubschutzmaske tragen : Llevar puesta una careta de protección contra el polvo : Indossare una mascherina anti-polvere : Utilizar uma máscara anti-poeira : Draag een stofmasker : χρήση προστατευτική μάσκα : Zakładać maskę przeciwpyłową Käytä pölysuojust : Bär mask mot damm : Der skal benyttes beskyttelsesmaske mod støv: Purtati mască anti-praf :</p>	<p><b>Наденьте респиратор :</b> Toza karşı maske takın : Používejte masku proti prachu : Noste ochrannú masku proti prachu : קבא דגנ הכסמ שובחל אנ ליבס קנא ע מוצאס ללדגבאר. Viseljen porvédő maszkot Nositi zaščitno masko proti prahu: <b>Да се използва защитна маска :</b> Kandke tolmumaski. Dėvėti respiratorių Valkät aizsarg masku pret putekljēm</p>	X
---	--	---	---

	<p>Porter une protection auditive: Wear hearing protective equipment: Gehörschutz tragen: Llevar puesta una protección auditiva: Portare una protezione uditiva: Utilizar uma protecção auditiva: Draag gehoorbeschermers: Φορέστε Προστατευτικά ακουστικά Zakładać słuchawki ochronne Käytä kuulosuojaimia: Bär hörselskydd: Der skal benyttes høreværn: Purtati căști de protecție auz:</p>	<p><b>наденьте средства звуковой защиты:</b> İşitsel koruma aleti takın: Používejte ochranu sluchu: Noste ochranné slúchadlá: יש ל הרכיב הגנת שמיעה ליבס גוידה צנצנ הצטייג. Viseljen fülvédőt Nositi zašito ušes: <b>Да се използва слухови защитни средства:</b> Kandke kõrvakaitset Nešioti apsaugą nuo triukšmo valkät dzirdes aizsarghdzekli</p>	X
--	---	--	---

	<p>Porter des gants : Use rubber gloves : Schutzhandschuhe tragen : Llevar guantes de protección : Indossare i guanti di protezione : Utilizar luvas de protecção : Draag veiligheidshandschoenen : χρήση προστατευτικών γαντιών : Używać rękawic ochronnych : Käytä suoja-käsineitä : Använd skyddshandskar : Der skal benyttes handsker : Purtati mănuși :</p>	<p><b>Наденьте перчатки :</b> Eldiven takın : Noste rukavice : Noste rukavice : תופכ שובלל אנ ליבס קנאזאט. Viseljen kesztyű t Nositi rokavice: <b>а се използват предпазни ръкавици :</b> Kandke kindaid Muvėti pirštinės Valkät cimduš</p>	X
---	--	---	---





Niveau de pression acoustique : Acoustic pressure level : Schalldruckpegel : Nivel de presión acústica : Livello di pressione acustica : Nivel de pressão acústica : Niveau akoestische druk : Στάθμη Θορύβου : Poziom mocy akustycznej : Käytä kuulosuojaimia : Ljudtrycksnivå : Lydtryk : Nivel presiune acustică :	<b>Уровень акустического давления :</b> Akustik basınç seviyesi : Hladina akustického tlaku : Hladina akustického tlaku : רמת לחץ אקוסטי. مستوى الضغط السمعي. A hangnyomás szintje : <b>Nivo akustičnega pritiska:</b> <b>Равнище на акустично налягане :</b> <b>Helirõhu tase</b> <b>Akustinio spaudimo lygis</b> <b>Akustiskā spiediena līmenis</b>	<b>66,6 dB (A)</b>
---	--	--------------------

Niveau de puissance acoustique : Acoustic power level : Schalleistungspegel : Nivel de potencia acústica : Livello di potenza acustica : Nivel de potência acústica : Niveau akoestisch vermogen : Στάθμη Ονομαστικής Θορύβου : Poziom mocy akustycznej : Käytä suoja-laseja : Ljudstyrkenivå : Lydstyrke : Nivel putere acustică :	<b>уровень мощности звука :</b> Akustik basınç seviyesi : Hladina zvukového výkonu : <b>Hladina zvukového výkonu:</b> רמת כוח אקוסטי. مستوى الضجيج. a hangnyomás szintje : <b>Nivo akustične jakosti :</b> <b>Равнище на вибрации :</b> <b>Helivõimsuse tase</b> <b>Triukšmo lygis</b> <b>Akustiskās jaudas līmenis</b>	<b>77,5 dB (A)</b>
---	--	--------------------

NIVEAU SONORE D'EMISSION:

A VIDE

Pression acoustique LpA poste opérateur  
Incertitude

66,6 dB  
3

Puissance acoustique LWA  
Incertitude

77,5 dB  
3

Valeurs déterminées suivant le code d'essai de l'annexe B de la norme EN 61029-1 avec emploi des normes de base ISO 11201 et ISO 3744.

Les niveaux de pression acoustique obtenus in situ dépendent:

- Des niveaux réels de la machine considérées, en prenant en compte les incertitudes déclarées;
- Du local et de l'installation de la machine. Préférez une pièce dont l'acoustique est plus feutrée. Evitez les pièces vide à grande résonance. Placez vous auprès d'une fenêtre le cas échéant.
- Des outils montés, des pièces travaillées, des réglages choisis,...

Niveau de vibration : Hand/arm vibration level : Vibrationspegel Hand/Arm : Nivel de vibración mano/brazo : Livello di vibrazione mano/braccio : Nivel de vibração mão/braço : Trillingsniveau hand/arm : Στάθμη κρα'οσμηών : <b>Poziom vibracji rżka/ramię :</b> Tärinätaso: Vibrationsnivå hand/arm : Vibrationsniveau : Nivel vibrații :	<b>Уровень вибрации :</b> Titreşim seviyesi : Úroveň vibrací : <b>Hladina vibráci :</b> רמת תנודות مستوى الارتجاج. Vibrációs szint : <b>Nivo vibracij :</b> <b>Равнище :</b> <b>Vibrācijas līmenis.</b> <b>Vibrācijas lygis</b> <b>Vibratsiooni tase</b>	<b>2,5 m/s<sup>2</sup></b>
---	---	----------------------------

VIBRATIONS:

Total des valeurs de vibration ( somme vectorielle des trois directions ) déterminée selon EN 60745:

a 2,5 m/s<sup>2</sup>  
Incertitude K 1,5 m/s<sup>2</sup>

L'amplitude d'oscillation peut être utilisée comme valeur de comparaison d'outils électroportatifs.

Attention: Si l'outil électroportatif est utilisé pour d'autres applications, avec d'autres outils de travail, l'amplitude d'oscillation peut être différente.





	<p>Conformité européenne          Conforms to EC standards :          CE-Konformität :          Cumple con las directivas CE :          Conforme alle norme CE :          Conforme às normas CE :          Voldoet aan de EG-normen :          Συμφώνο με τα πρότυπα          Zgodność z normami CE :          EU-standardien mukainen :          EU-standardien mukainen :          Overholder EU standarderne :          Conform cu normele europene:</p>	<p><b>соответствие европейским стандартам:</b>          Avrupa uygunluk :          evropská shoda :          európska dohoda :          התאמה לתקנים האירופיים          مطابق للخواصفات الأوروبية          evropska ustreznost :          európai megfeleléség :  <b>Съответствие с европейските норми :</b>  <b>Euroopa Liidu vastavusmärk</b>  <b>Europinių normų atitikima</b>  <b>Atbilstība Eiropas standartiem</b></p>	<p>X</p>
---	---	--	----------

	<p>Lire les instructions avant usage :          Read the instructions before use :          Vor Einsatz des Geräts Anweisung lesen :          Léase las instrucciones antes de usar :          Leggere le istruzioni prima dell'uso :          Ler as instruções antes da utilização :          Lees voor het gebruik de instructies :          Διαβάστε τις οδηγίες χρήσης :          Zapoznać się z instrukcją przed użyciem :          Lue ohjeet ennen käyttöä :          Läs anvisningarna före användning :          læs instruktionerne før brug          Înainte de utilizare, citiți instrucțiunile :</p>	<p><b>Внимательно прочитайте следующие инструкции :</b>          Kullanmadan talimatları okuyunuz :          Pozorně si přečtěte následující pokyny :          Pred použitím si prečítajte pokyny :          זרם הילופי          اقرأ التعليمات قبل الاستخدام.          használat előtt olvassuk el az utasítást :          Pred uporabo preberite ustrezná navodila :  <b>Прочетете указанията за употреба :</b>  <b>Enne kasutamist lugege instruksiooni</b>  <b>Prieš naudojimą perskaityti instrukciją</b>  <b>izlasīt instrukcijas pirms lietošanas</b></p>	<p>X</p>
---	--	--	----------

	<p>Danger :          Danger :          Gefahr :          Peligro :          Pericolo :          Perigo :          Gevaar :          Κιίνδυνος :          Niebezpieczeństwo :          Vaara :          Fara :          Fare :          Pericol :</p>	<p><b>Опасно :</b>          Tehlike :          Nebezpečí :          Nebežpečenstvo :          סכנה.          خطر.          Veszély :          Nevarnost:  <b>Опасно :</b>  <b>Oht</b>  <b>Pavojus</b>  <b>Bīstamība</b></p>	<p>X</p>
---	--	---	----------

	<p>Recyclable, soumis au tri sélectif          Recyclable, subject to recycling          Recyclingfähige, unterliegen Recycling          Reciclables, sujetos a reciclaje          Riciclabili, soggetti a riciclaggio          Recicláveis, sujeitos à reciclagem          Recycleerbare, onderworpen aan recycling          Ανακυκλώσιμες συσκευασίες που υπόκεινται σε κύκλωση          Opakowanie nadaje się do recyklingu podlegają recyklingu          Kierrätettävien pakkausten kohteena kierrätys          Återvinningsbara förpackningar omfattas återvinning  <b>Рециклиращи се опаковки подлежат на рециклиране</b>          Genanvendelig underlagt genbrug</p>	<p>Reciclabile sub rezerva reciclare  <b>Повторно опаковка подлежат вторичной переработке</b>          Geri dönüştürülebilir ambalaj konusu          Recyklovateľné podliehajúci recyklácii          Recyklovateľné podliehajúce recyklácii          הוחמל הוחמל הזיראה אשון          ریودنلا هاهال عنضعت ریودنلا هاهال تلبااوالا نغیل نجلالو قوبع نجلالو          Újrahasznosítható csomagolás alá újrahasznosítás          Reciklirati predmet recikliranja          Pakendite suhtes ringlussevõtu          Pārstrādājams iepakojumus otrreizējai pārstrādei          Perdīrbamų taikomos perdirbimo</p>	<p>X</p>
---	--	---	----------





	<p>Soumis à recyclage Subjected to recycling Sujeto a reciclaje Sottoposti a riciclaggio Sujeitos à reciclagem Nāo deite no lixo : Niet wegwerpen : Μην την πετάτε : Nie wyrzucas : Älä heittä pois luontoon : Batteriet får inte kastas : Bortkast det ikke: Nu le auncati :</p>	<p>Не выбрасывайте в мусорный ящик Atmayıniz : Nevyhazujte je do bežného odpadu : Neodhadzovat : אין לזרוק סוללות فلا ترمدها لنذا في القمامة. ne mečíte! Ne odvržite ga/jih vstran : Не го изхвърляйте : Ärge visake seda minema : Nemétykíte : Nemest :</p>	X
--	---	--	---

**FR-Recyclage des déchets:**

Les outils, accessoires et leur emballages doivent suivre une voie de recyclage adaptée. Conformément aux directives Européenne 2002/96/CE et 91/157/CEE, les composants d'un produit doivent être séparés, collectés, recyclés ou éliminés en conformité avec les réglementations environnementales en vigueur. Les appareils, batteries, piles, huiles, emballages devront être déposés dans les systèmes d'élimination des déchets spéciaux tels que déchetteries. Renseignez vous auprès de votre commune pour connaître l'organisme le plus proche à même de retraiter ou de collecter ces déchets.

**NL-Waste Recycling:**

Gereedschappen, accessoires en de verpakking moet een recycling traject aangepast volgen. Overeenstemming met de Europese Richtlijnen 2002/96/EG en 91/157/EEG, de onderdelen van een product moet worden gescheiden, verzameld, gerecycleerd of verwijderd in overeenstemming met de milieuvorschriften. Apparaten, batterijen, olie, moet de verpakking worden gedeponoerd in de verwijdering van gevaarlijke afvalstoffen, zoals afvalverwerking systemen. Informeer bij uw gemeente naar de dichtstbijzijnde staat om opnieuw te verwerken of te verzamelen het afval lichaam te vinden.

**EN-Waste recycling:**

The tools, accessories and their packaging must use an appropriate recycling channel. In compliance with European Directives 2002/96/EC and 91/157/EEC, a product's components must be separated, collected, recycled or eliminated in accordance with the environmental regulations in force. The appliance, batteries, oils and packaging must be deposited in the special waste elimination systems such as the waste collection centres. Ask your commune for information on the nearest organisation in a position to reprocess or collect this waste

**ES-Reciclado de los residuos:**

Las herramientas, los accesorios y los envases tienen que seguir la vía de reciclaje adecuada. En virtud de las directivas europeas 2002/96/CE y 91/157/CEE, los componentes de un producto deben separarse, recogerse, reciclarse o eliminarse de acuerdo con las reglamentaciones medioambientales vigentes. Los aparatos, baterías, pilas, aceites, envases deberán llevarse a los centros de eliminación de residuos especiales tales como los ecoparques. Pedir información al municipio par conocer el centro más cercano apto para reciclar o recoger dichos residuos.

**IT-Riciclaggio dei rifiuti:**

Gli apparecchi, i loro accessori ed imballaggi devono essere sottoposti ad un processo di riciclaggio appropriato. In conformità con le direttive europee 2002/96/CE e 91/157/CEE, i componenti di un prodotto devono essere separati, raccolti, riciclati o smaltiti in conformità con le normative ambientali in vigore. Gli apparecchi, le batterie, le pile, gli oli, gli imballaggi dovranno essere conferiti nei sistemi di smaltimento dei rifiuti speciali come le isole ecologiche. Informarsi presso il proprio comune per sapere qual è l'ente più vicino in grado di fare il trattamento o la raccolta differenziata di questi rifiuti

**PT-Reciclagem do lixo:**

As ferramentas, acessórios e suas embalagens devem seguir um canal de reciclagem adaptado. Conformemente às diretivas europeias 2002/96/CE e 91/157/CEE, os componentes de um produto devem ser separados, recolhidos, reciclados ou eliminados de acordo com as regulamentações ambientais em vigor. Os aparelhos, baterias, pilhas, óleos e embalagens deverão ser depositados nos sistemas de eliminação de detritos especiais, tais como unidades de triagem de detritos. Informar-se junto ao seu concelho municipal para conhecer o órgão mais próximo habilitado a evacuar ou recolher estes detritos.





MS 3625

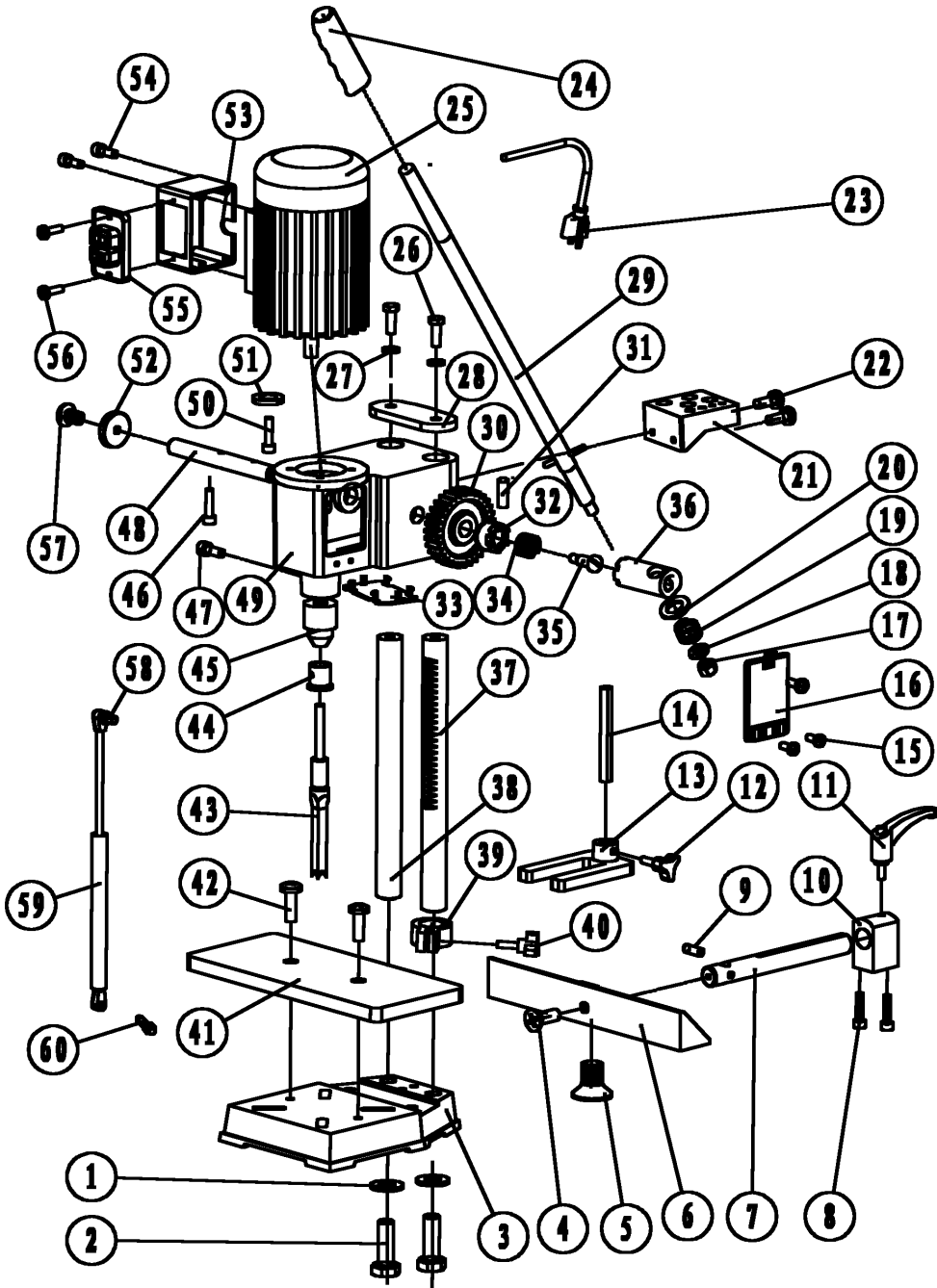



# Plaques signalétiques - naamplaatjes - placas de identificación - placas de identificação - targhette - machine labels

**FAR TOOLS**

MS3625  
113770

230 V ~ 50 Hz    370 W    1400 min<sup>-1</sup>

76 mm    13 mm / B16    150 x 340 mm

24,5 kg

CE

Serial number / numéro série :  
MS36127A3  
Made in P.R. C.  
FAR GROUP EUROPE Saint Pierre (37700) - FRANCE

113770-Sticker-C.indd 1      18/05/15 10:52:37







**VERKLARING VAN OVEREENSTEMMING**  
**DECLARATION DE CONFORMITE**  
**KONFORMITÄSERKLÄRUNG**  
**DECLARAÇÃO DE CONFORMIDADE**  
**OM ÖVERENSSTÄMMELSE**  
**Overensstemmelseerklæring**

Declarație de conformitate  
 Декларация соответствия  
 UYGUNLUK BEYANI  
 Prohlášení shody  
 Декларация за съответствие с нормите

**DECLARACION DE CONFORMIDAD**  
**DICHIARAZIONE DI CONFORMITA**  
**DECLARATION CONFORMITY**  
**DEKLARACJA ZGODNOSCI Z NORMAMI**  
**VAATIMUSTENMUKAISUUSVAKUUTUS**  
**Δήλωση συμμόρφωσης/συμμόρφωσης**  
 Vyhlášení zhody  
 הצהרת תואמת  
 التصريح بالمتطابق ة  
 Egyezőségi nyilatkozat  
 Izjava o skladnosti

Ondergetekende,  
 Le soussigné,  
 Der Unterzeichner,  
 O abaixo assinado,  
 Undertecknad,  
 Долуподписаният  
 Undertegnede  
 Subsemnatul,  
 Я, нижеподписавшийся,  
 Ímzalayan,  
 Níže podepsaný,

Personne autorisée à constituer  
 le dossier technique:  
 Christophe HUREL

El suscrito,  
 Il sottoscritto,  
 The undersigned,  
 Nínej podpisany  
 Allekirjoittanut,  
 Ουπτογεγραμμένος/  
 Nižšie podpísaný  
 הטתנתה,  
 الجوق ع أدناه  
 Alulírott,  
 Podpisani,

Verklaart hiermede dat,  
 Déclare par la présente que,  
 Erklärt hiermit daß,  
 Declara pela presente que,  
 Förklarar härmed att  
 Заявява с настоящото  
 erklærer hermed, at  
 Declar prin prezenta că,  
 настоящим подтверждаю, что  
 Mevcut belgeyle beyan ediliyor ki,  
 tímto prohlašuje, že,



FAR GROUP EUROPE  
 192, Avenue Yves FARGE  
 37700 Saint-Pierre-des-Corps  
 FRANCE

Declara por la presente, que,  
 Dichiare che,  
 Declares that,  
 OÖwiadcza niniejszym, że  
 Ilmoitetaan täten että,  
 Δηλώνει με τη παρούσα  
 týmto vyhlasuje, že  
 מצהיר בזה כי  
 يصدرح إسنادا على ذلك  
 kijelentem, hogy a készülék Izjavlja da,

**Mortiser/ Mortaiseuse /**

**Stemmashine / Mortajadora / Mortasatrice / Escatelador / Steekbank / ΜΗΧΑΝΗ ΔΙΑΤΡΗΣΗΣ / DLUTARKA /**  
**Pistoijyrinkone / Stickmaskin / ДЪЛБАЧНА МАШИНА / Taphulsmaskine / MAŠINÁ DE MORTEZAT. / ДОЛБЕЖНЫЙ СТАНОК. /**  
**PLANYA MAKINESI. / SVISLÝ OBRÁZECÍ STROJ. / ДЛАВАЧКА. / یق دویبعل הצרחה / بشوعلا قراون / CSAPLYUKVÉŠÓ GÉP / VERIŽNI REZKAR.**  
**/ TAPIFREES / GROPETÁJS / SUJUNGIMO LIZDŲ SKOBTUVAŠ.**

code

FARTOOLS / 113770 / MS 3625 / MS 36127A3

In overeenstemming is met en Voldoet aan EG richtlijnen,  
 Est conforme et satisfait aux normes CE,  
 Den folgenden EU-Bestimmungen entspricht,  
 Respeita e está em conformidade com as normas CE,  
 Överensstämmer med och uppfyller EG-standarder,  
 Съответства и отговаря европейските норми  
 er i overensstemmelse med og overholder EU standarderne  
 Este conform și satisface normele CE  
**подобають соответствует и удовлетворяет**  
**требованиям стандартов ЕС**  
 CE şartlara uygundur,  
 odpovídá normám ES.

2006/42/EC, 2014/30/EU,  
 2011/65/EU  
 2015/863/EU

EN 61029-1: 2009  
 EN 55014-1:2006+A1+A2  
 EN 61000-3-2:2014  
 EN 61000-3-3:2013  
 EN 55014-2:2015

Cumple con la directivas de la CE,  
 E conforme alle direttive CEE,  
 Complies with the EEC standards,  
 Odpowiada normom UE,  
 Täyttää EU-vaatimukset,  
 Είναι σύμφωνα και ανταποκρίνεται στα Πρωτόκολλα CE  
 zodpovedá normám ES.  
 מתאים ועונה לתקני CE  
 بأن الجهاز مطابق و يلبي معايير مجموعة الدول الأوروبية  
 kielégíti a CE szabványok előírásait.  
 Je v skladu z in izpolnjuje norme Evropske skupnosti.

Christophe HUREL,  
 Président Directeur Général  
 14/05/2017  
 Fait à Saint Pierre des Corps





#### FR. GARANTIE

Cet outil est garanti contractuellement contre tout vice de construction et de matière, à compter de la date de vente à l'utilisateur et sur simple présentation du ticket de caisse. La garantie consiste à remplacer les parties défectueuses. Cette garantie n'est pas applicable en cas d'exploitation non conforme aux normes de l'appareil, ni en cas de dommages causés par des interventions non autorisées ou par négligence de la part de l'acheteur. La garantie ne s'applique pas sur les dommages causés par une défaillance de l'outil.

#### DE. GARANTIE

Die Garantiezeit für dieses Gerät in bezug auf Konstruktions- und Materialfehler beträgt lt. Vertrag bei Vorlage des Kassensbons. Die Garantieleistung besteht im Ersatz schadhafter Teile. Die Garantie erlischt bei einem Einsatz des Geräts, der nicht normentsprechend ist, bei Schäden, die auf unsachgemäße Eingriffe zurückzuführen sind bzw. bei Nachlässigkeit seitens des Käufers. Die Garantie erstreckt sich nicht auf Schäden, die auf Fehlfunktionen des Geräts zurückzuführen sind.

#### IT. GARANZIA

Quest' attrezzo è garantito per contratto contro qualsiasi difetto di costruzione e di materia, a partire dalla data di vendita all'utente e su semplice presentazione dello scontrino. La garanzia consiste nel sostituire le parti difettose. Questa garanzia non è applicabile in caso di sfruttamento non conforme alle norme dell'apparecchio, né in caso di danni causati da interventi non autorizzati o da negligenza da parte dell'acquirente. La garanzia non si applica ai danni causati da un'avaria dell'attrezzo.

#### EN. GARANTEE

This tool is guaranteed, in writing, against any defect in manufacture or parts from the date of sale, upon simple presentation of the sales slip. The guarantee is limited to the replacement of faulty parts. This guarantee is not applicable in the event of usage which is not conform with the intended usage of the apparatus, nor in the event of damage caused by unauthorised servicing or negligence on behalf of the purchaser. This guarantee does not apply to any damage caused by the failure of this tool.

#### ES. GARANTIA

Esta herramienta se garantiza contractualmente contra todo defecto de construcción y materia, a partir de la fecha de venta a l'usuario y sobre simple presentación del recibo de caja. La garantía consiste en sustituir a las partes defectuosas. Esta garantía no es aplicable en caso de explotación no conforme a las normas del aparato, ni en caso de daños causados por intervenciones no autorizadas o por negligencia por parte del comprador. La garantía no se aplica sobre los daños causados por un fallo del herramienta.

#### NL. GARANTIE

Dit gereedschap heeft een garantie tegen constructiefouten en materiaaldefecten, die geldig is vanaf de aankoopdatum door de gebruiker, op vertoning van de kassabon. De garantie betreft de vervanging van de defecte onderdelen. Deze garantie is niet van toepassing indien het apparaat niet volgens de normen gebruikt is, noch in geval van schade veroorzaakt door oneigenlijk gebruik of nalatigheid van de koper. De garantie is niet van toepassing op schade voortvriend uit een defect van het gereedschap.

#### PT. GARANTIA

Esta ferramenta tem uma garantia contratual contra qualquer defeito de construção e de material, a partir da data de venda ao utilizador e sobre simples apresentação do talão da caixa. A garantia consiste em substituir as partes defeituosas. Esta garantia não é aplicável no caso de exploração não conforme às normas do aparelho, nem em caso de danos causados pelas intervenções não autorizadas ou por negligência da parte do comprador. A garantia não se aplica para os danos causados por uma falha da ferramenta.

#### EL. Εγγύηση

Το εργαλείο αυτό φέρει συμβατική εγγύηση για οποιούδήποτε ελάττωμα κατασκευής απ'ο την ημερομηνία Πώλησης στο χρήστη. με απλή Προσκόμιση της απ'οσοειζησ αγοράς. Η εγγύηση αποτελείται απ'ο την αντικατάσταση των ελαττωματικών τμημάτων. Η Παρούσα εγγύηση οεν εφαρμόζεται σε περίπτωση χρήσης μη σύμφωνα με τα Πρότυπα της συσκευής, η σε περίπτωση ζημιών που Προκαλήθηκε απ'ο μη εγκεκριμένη επέμβαση ή απ'ο αμέλεια του αγοραστή. Η εγγύηση οεν εφαρμόζεται στις ζημιές που Προκαλούνται απ'ο βλάβη του εργαλείου Σταυροί κενού Διασθημο-Παρέμβυσμα

#### PL. GWARANCJA

Narz dzie jest objte gwarancj na wszelkie wady konstrukcyjne i materia[owe, liczàc od daty sprzeday uytownikowi i po okazaniu paragonu kasowego. Gwarancja obejmuje wymian czci wybrakowanych. Gwarancja nie znajduje zastosowania w przypadku uytowania niezgodnego z normami urzàdzenia, ani w przypadku szkód spowodowanych dzia[aniami niedozwolonymi lub zaniebdaniami ze strony nabywcy. Gwarancja nie obejmuje szkód powstajych z powodu upadku urzàdzenia.

#### SV. GARANTI

Detta verktyg har en avtalsenlig garanti mot konstruktions- och materialfel, från och med tidpunkten för användarens inköp och genom uppvisning av kasskvittot. Garantin består i att ersätta de bristfälliga delarna. Denna garanti gäller inte om användningen inte motsvarar apparatens standarder, inte heller vid skador som orsakas av ej tillåtna ingrepp eller på grund av köparens vårdslöshet. Garantin gäller inte för skador som orsakats av att verktyget fungerat bristfälligt.

#### FI. TAKUU

Tämän laitteen takuu on voimassa sopimuksenmukaisesti kattaen kaikki rakenne- ja materiaaliiviat lukien ostopäivästä kassakuittia vastaan. Takuu sisältää viallisten osien korvaamisen. Takuu ei korvaa ohjeidenvastaista käyttöä eikä valtuuttamattomien henkilöiden käsittelystä tai ostajan huolimattomuudesta aiheutuneita vahinkoja. Takuu ei vastaa myöskään toimintahäiriöistä aiheutuneita vahinkoja.

#### VU. Гаранция

Този инструмент е под договорна гаранция срещу всякакъв дефект в изработката и използваните материали, считано от датата на продажба на потребителя и само срещу представяне на касовата бележка. Гаранционното обслужване се състои в замяна на дефектните части. Настоящата гаранция не е валидна когато апаратът се използва по начин, несъответстващ на стандарта за работа с него, както и в случай на щети, нанесени от неоторизирани лица, или вследствие на проявена небрежност от страна потребителя.

Гаранцията не покрива щети, произтекли вследствие на техническа неизправност на апарата.





#### DA. GARANTI

Dette værktøj er dækket af en garantikontrakt for konstruktions- og materialefejl, som gælder fra købsdatoen ved visning af kassebonen. Garantien består i at udskifte de defekte dele. Garantien dækker ikke fejl opstået som følge af anvendelse, som ikke overholder standarderne for apparatet, eller skader opstået ved ikke autoriserede indgreb eller sløsethed fra brugerens side. Garantien dækker ikke skader opstået, fordi værktøjet har svigtet.

#### RO. GARANȚIE

Acest aparat este garantat din punct de vedere contractual împotriva tuturor viciilor de construcție și de material, începând de la data vânzării lui către utilizator și la simpla prezentare a bonului de casă. Garanția constă în înlocuirea componentelor defecte. Această garanție nu se aplică în cazul exploataării în alt mod decât cel recomandat de normele aparatului și nici în caz de stricăciuni provocate de intervenții neautorizate sau prin neglijența cumpărătorului. Garanția nu se aplică asupra pagbelor cauzate de o defectare a aparatului.

#### RU. ГАРАНТИЯ

Данное изделие обладает имеющей силу контракта гарантией, покрывающей все возможные дефекты изготовления и материала. Гарантия вступает в силу с даты продажи изделия пользователю, для этого достаточно сохранить и предъявить полученный в кассе чек. Гарантия обязывает изготовителя заменить дефектные части изделия. В случае не соответствующего нормам использования изделия, несанкционированного демонтажа или ремонта или небрежного обращения действие гарантии прекращается. Гарантия не покрывает ущерба, возникшего в результате сбоев в работе изделия.

#### TU. GARANTI

Bu araç, satış tarihinden itibaren, kullanıcının sadece vezne alındısını sunmasıyla tüm üretim ve malzeme hatasına karşı garantilidir. Garanti eksik olan kısımlardan değiştirilerek içindir. Bu garanti aracın şartlarına uygun olmayan işleme durumunda, izin verilmeyen kullanımlardan kaynaklanan hasarlarda veya alıcının isteği durumunda uygulanmaz. Garanti malzemenin bir eksikliğinden meydana gelen bir zararda uygulanmaz.

#### CS. ZÁRUKA

Pro tento nástroj platí smluvní záruka na všechny výrobní a materiálové vady od data prodeje uživateli a na základě předložených pokladničního bloku. Záruka spočívá ve výměně vadných částí. Tato záruka neplatí v případě použití přístroje, které neodpovídá normám, ani v případě škod způsobených nepovolenými zásahy nebo nedbalostí ze strany kupujícího. Záruka se nevztahuje na škody způsobené závadou nástroje.

#### SK. ZÁRUKA

Pre tento nástroj platí zmluvná záruka na všetky výrobné a materiálové chyby od dátumu predaja užívateľovi a na základe predloženia pokladničného bloku. Záruka spočíva vo výmene chybných častí. Táto záruka neplatí v prípade použitia prístroja, ktoré nezodpovedá normám, ani v prípade škôd spôsobených nepovolenými zásahmi alebo nedbalosťou zo strany kupujúceho. Záruka sa nevzťahuje na škody spôsobené poruchou nástroja.

#### HE. אחריות

הי עלכלי זה חלה אחריות לפי חוזה מפני כל ליקוי בייצור או בחומר, החל מיום המכירה למשתמש עם הצגת חשבונית קופה. האחריות-משמעה החלף תחלקם הלקויים אחריות זו אינה חלה במקרה של שימוש במכשיר שאינו מתאים לתקנים ובמקרה של נזק שנגרם על ידי התערבותי תללל סמכות או על ידי רשלנות מאת הקונה. האחריות אינה חלה על נזק שנגרם על ידי תקלה בכלל.

#### AR. الضمان

إن هذه العدة مضمونة تعاقدياً من أي عيب فني التصدي عوقفي الجوار. إعتباراً من تاريخ البيع إلى المشتري عمل وبناءاً على مجرد تقديم بطاقة الشراء. يتعلّق الضمان فبأي استبدال الأجزاء الأعطلة لا يُلون هذا الضمان قابلاً للتطبيق في حالة الاستخدام غير المطابق لمعايير الجهاز، ولا في حالة تعرضه لتآكل أو تلف ناتج عن عمليات تعديل غير مصرح بها أو في حالة الإهمال من قبل المشتري لا يتطابق الضمان على الخردة الناتج عن غل

#### HU. GARANCIJA

Erre a szerszámra szerződéses garanciát vállalunk bármilyen gyártási és anyaghiba felmentülése esetére, a fogyasztó részére történő eladás napjától számítva, a pénztári blokk egyszerű felmutatása ellenében. A garancia a hibás alkatrészek cseréjére terjed ki. Ez a garancia nem érvényes, ha a készülék nem rendeltetésszerűen használták, sem illetéktelen beavatkozások, vagy a vásárló hanyagsága okozta károk esetén. A garancia nem fedezi azokat a károkat, melyeket a szerszám hibás működése okozott.

#### SL. GARANCIJA

To orodje je z garancijsko pogodbo zaščiteno proti vsem napakam v izdelavi in v sestavnem materialu od datuma prodaje naprej in ta velja ob predložitvi blagajniškega računa. Garancija velja za zamenjavo delov z napako. Ta garancija ne velja za uporabo orodja, ki ni v skladu z normami, predpisanimi za omenjeno orodje in za primere okvar, ki nastanejo zaradi nedovoljenih posegov na orodju ali zaradi malomarnega rokovanja kupca. Garancija ne velja za škodo, ki jo lahko povzroči okvara orodja.

#### ET. GARANTII

See tööriist kuulub lepingu järgi garantiiremonti arvestades alates müümise päevast ja kasatšeki alusel kasutajale kõigi konstruktsiooni- ja materjalivigade puhul. Garantii seisneb defektsete osade väljavahetamises. See garantii ei kehti aparadi normide ebaavalise eiramise puhul ega ostja poolt keelatud viisil kasutamistest või hooletussejätmisest tulenevate kahjude korral. Garantii ei kehti seadme defektidest põhjustatud kahjude puhul.

#### LV. GARANTIJA

Šis prietaisas yra užtikrinamas kaip itin geros kokybės, nuo jo pardavimo datos iki jo panaudojimo, ir jam yra suteikiamas garantinis talonas. Garantijos metu galima pakeisti atsiradusius trumplataikus gedimus. Ši garantija netaikoma esant netinkamam naudojimui ar nesilaikant reikiam šio aparato vartojimo instrukcijų, tai pat pačiam pirkejiui jį sugadinus. Garantija taip pat netaikoma, prietaisą naudojant ne pagal paskirtį ir jį apgadinus.

#### LT. GARANTIJA

Šim darbarikam ir ligumā noteikta garantija visiem defektiem, kas saistās ar konstrukciju un materiālu, sākot ar pārdošanas datumu, kad mašīnu pārdo lietotājam un vienkārtī uzrādot kases čeku. Garantija iekļauj bojāto daļu nomaiņu. Šī garantija nav derīga, ja aparāts nav lietots saskaņā ar drošības noteikumiem, ne gadījumos ja bojājumi radušies nesankcionētas iejaukšanās gadījumā vai arī pircēja nolaidības dēļ. Garantija nav derīga, ja bojājumi radušies darbarika defekta dēļ.

