

FAR one® TOOLS



CP 150
Simple Machine

© FAR GROUP EUROPE

113200-G-20180604

FR	<i>Combiné ponceur (Notice originale)</i>
EN	<i>Belt and disc sander (Original Manual translation)</i>
DE	<i>Combischleifer</i>
ES	<i>Lijadora Combinada (Traducción del manual de instrucciones originale)</i>
IT	<i>Levigatrice combinata (Traduzione dell'avvertenza originale)</i>
PT	<i>Lixasdeira (Tradução do livro de instruções original)</i>
NL	<i>Bandschuurachine et schuurschijf</i>
EL	Παλι υδρο μκ'οσ
PL	<i>Kombinacja szlifierek</i>
FI	<i>Lautas/nauhahiomakone</i>
SV	<i>Bandslipmaskin med sliptallrik</i>
BU	<i>Bandslipmaskin med sliptallrik</i>
DA	<i>Kombineret slibemaskine</i>
RO	<i>Mașină de șlefuit combinată</i>
RU	<i>Комбинированный шлифовальный станок</i>
TU	<i>Bant ve diskli kombine zımpara makinesi</i>
CS	<i>Kombinovaná bruska</i>
SK	<i>Kombinovaná brúska</i>
HE	יתילכת-בר שוטיל תנוכמ
AR	آي رادم لقص قلا
HU	<i>Kombinált csiszoló</i>
SL	<i>kombiniran polirni stroj</i>
ET	<i>Kombineeritud lihviija</i>
LV	<i>Kombinuota (mišri) grēžimo mašina</i>
LT	<i>Kombinėta slīpmašina</i>

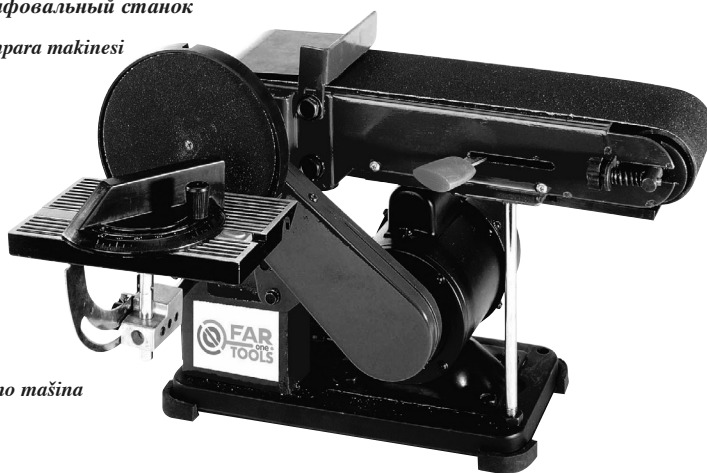

www.fartools.com



Contenu du carton
Inhoud van de doos
Conteúdo da caixa
Contenido de la caja
Contenuto della confezione
Contents of the box

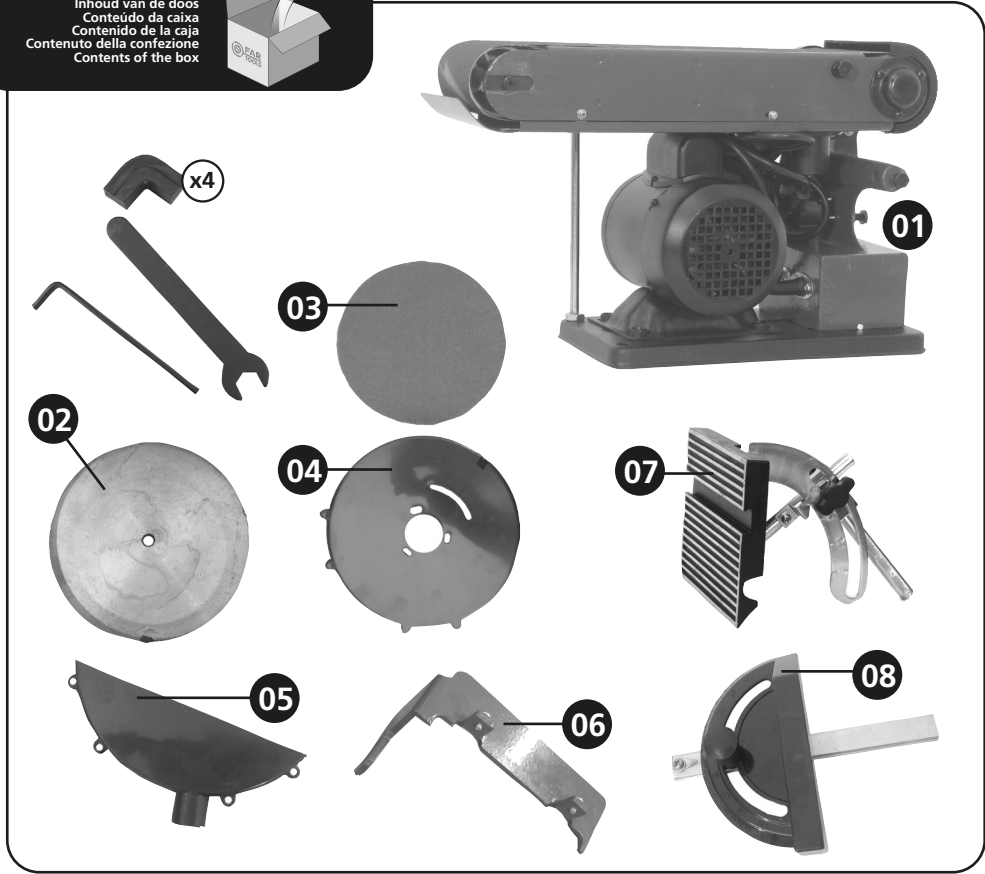

1

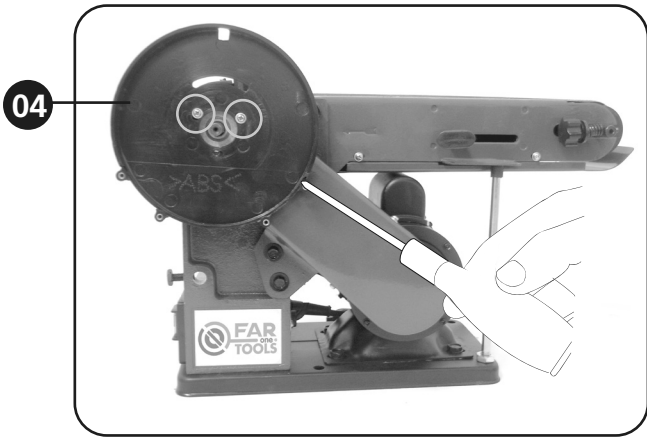

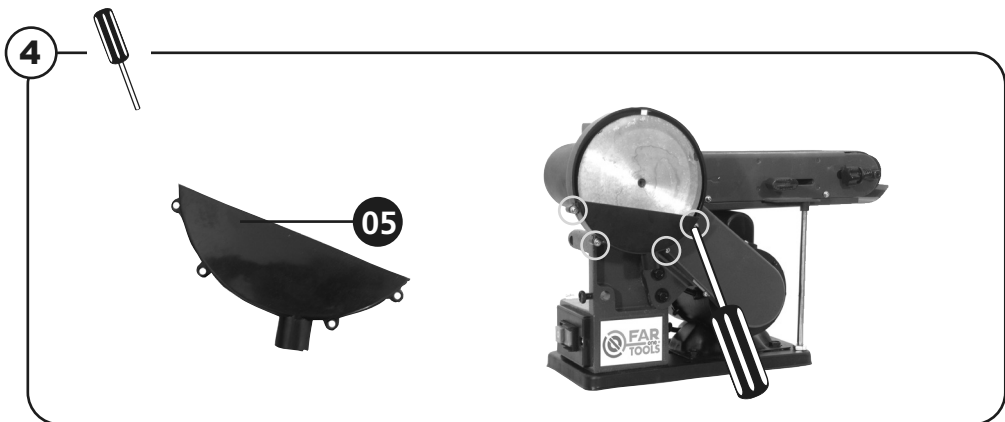
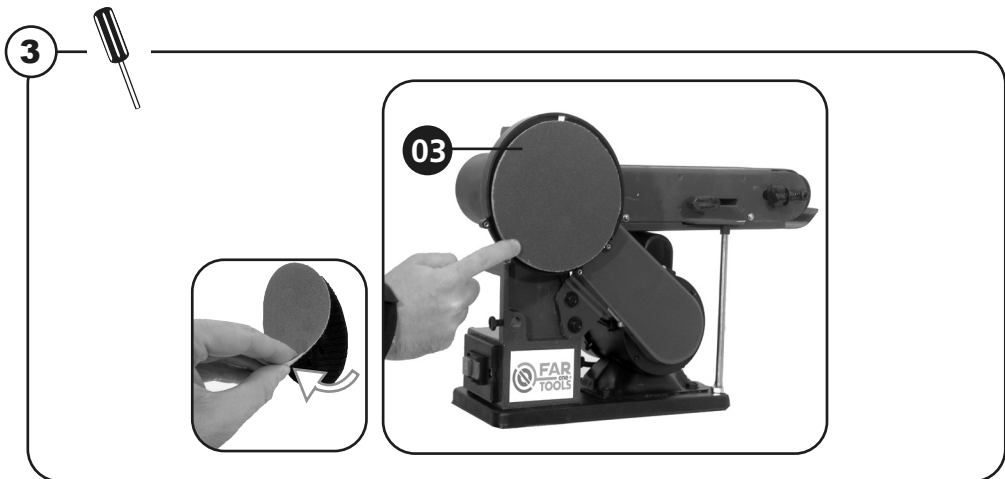
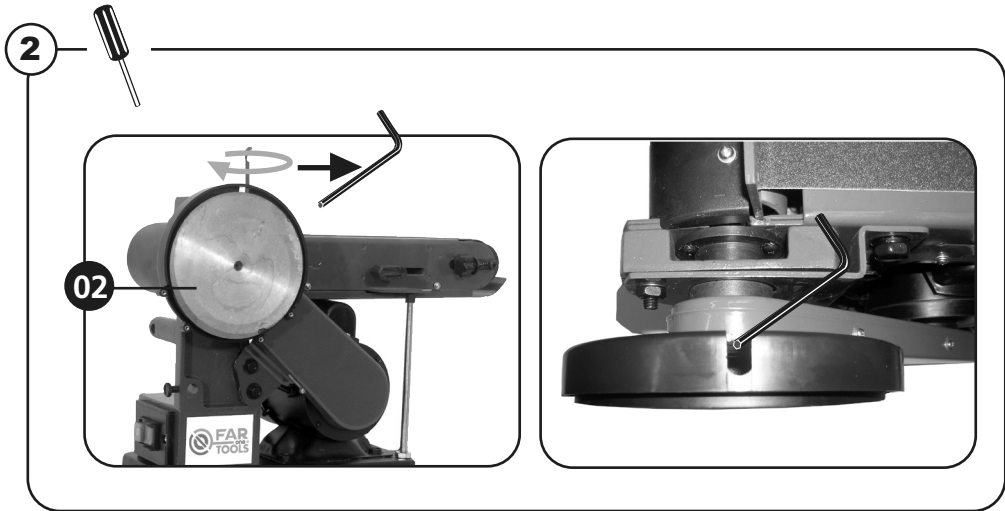



5

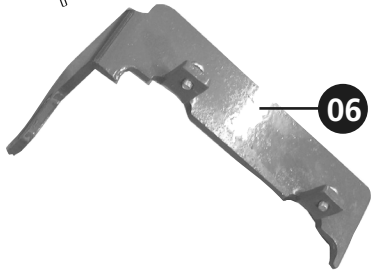

06

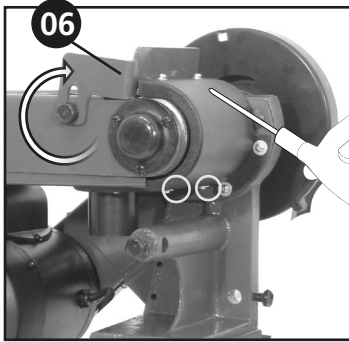

06

6

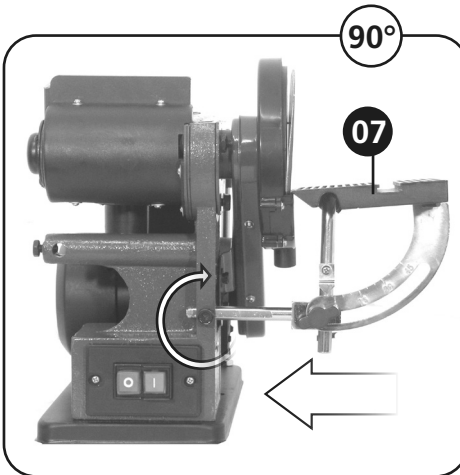

90°

07

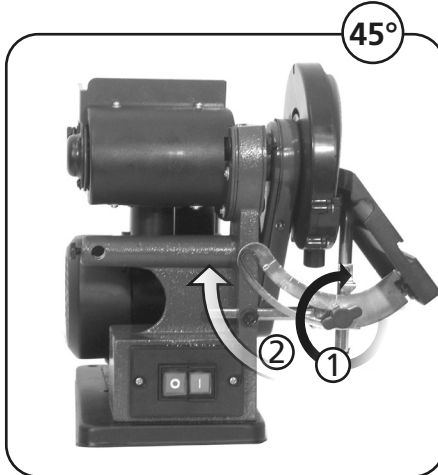

45°

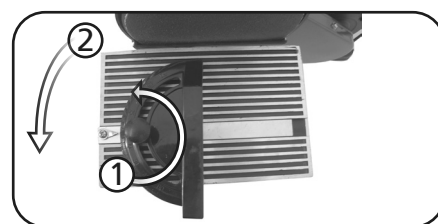
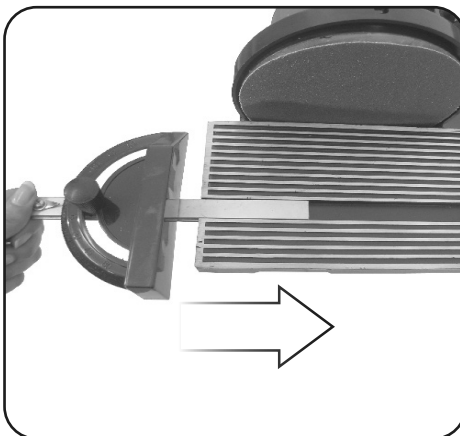

2

1

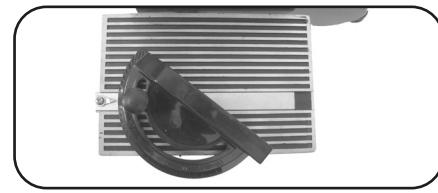



7

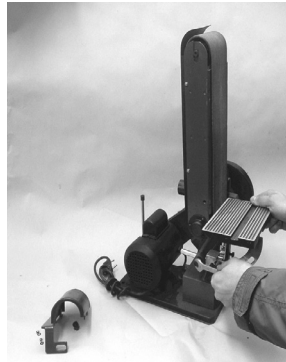
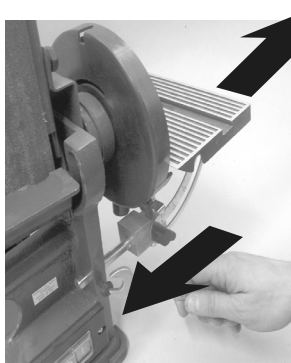
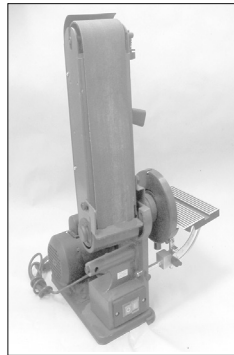

8

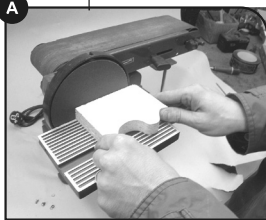
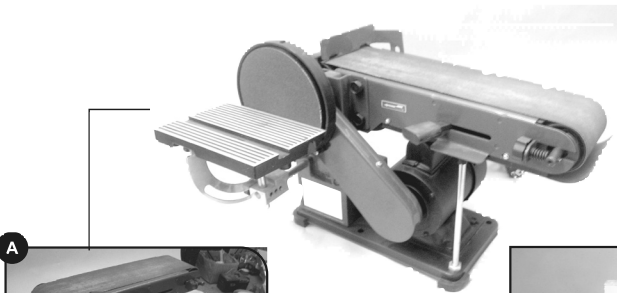
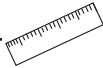



1

1

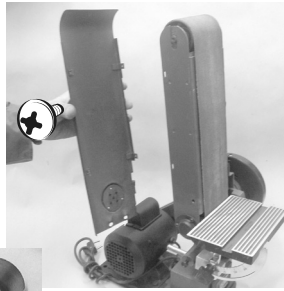
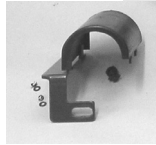
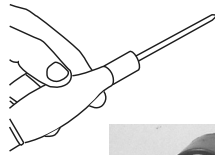

2



3

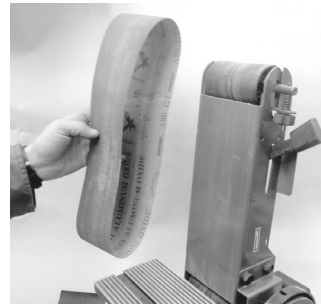
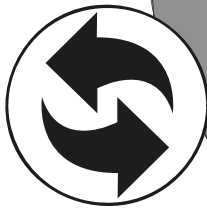

4

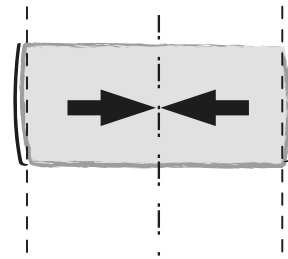

113259

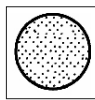

150 mm

A 40x2
A 80x2
A 120x2

113360

113361

113362





100x914

A 120x2
A 80x2
A 40x2





	<p>Tension et fréquence assignée: Nominal frequency and power: Spannung und Frequenz: Tensión y frecuencia fijada: Tensione e frequenza assegnata: Tensão e frequência fixa: Aangewezen spanning en frequentie: Όνομαστωμένη τάση και συχνότητα: Napięcie i częstotliwość przydzielona: Jännite ja määrätty taajuus: Angiven spänning och frekvens: Anført spænding og frekvens: Tensiune și frecvență de lucru:</p>	<p>Заданное напряжение и частота: Tahsis gerilimi ve frekansı: Stanovené napětí a frekvence: Stanovené napätie a frekvencia: מחמת ותדר מוקצב الغلطية والذبذب المبرمجة. Névfleges feszültség és frekvencia: Napetost in določena frekvenca: Консумирано напрежение и честота : Määratud pinge ja sagedus Nustatyta įtampa ir dažnis Noteiktas spriegums un frekvence.</p>	230 V ~ 50 Hz
---	--	---	----------------------





	<p>Vitesse à vide: No-load speed: Drehzahl unbelastet: Velocidad vacía: Velocità a vuoto: Velocidade no vácuo: Leerlaufdrehzahl: Ταχύτητα στο κενό: Prędkość bez obciążenia: Tyhjäkäyntinopeus Tomgångshastighet: Hastighed i ubelastet tilstand: Viteza în gol:</p>	<p>Скорость вращения на холостом ходу: Boşalma hızı: Rychlost naprázdno: Rýchlost' pri chode naprázdno: מהירות ריק. السرعة على الفارغ. Üres sebesség: Prosti tek: Скорост на празни обороти: Kiirus tühikäigul Tuščio prietaiso greitis Tukšgaitas ātrums</p>	1450 min⁻¹
---	--	--	------------------------------

	<p>Puissance assignée: Nominal power: Leerlaufdrehzahl: Potencia fijada: Potenza assegnata: Potência assinada: Onbelast toerental: Όνομαστωμένη ισχύς : Prędkość na biegu jałowym: Teho: Angiven effekt: Anført styrke: Putere de lucru:</p>	<p>Заданная мощность: Tahsis edilen gücü: Stanovený příkon: Predpísaný výkon: כוח מוקצב. القدرة المبرمجة. Névfleges teljesítmény : Določena jakost: Консумирана мощност: Määratud võimsus. Nustatyta galia Noteiktā jauda</p>	375 W (S2)
--	--	--	-------------------

	<p>Poids : Weight : Gewicht : Peso : Peso : Peso : Gewicht : Βάρος : Masa : Paino : Vikt : Vægt : Greutate :</p>	<p>Вес : Ağırlık : Hmotnost : Hmotnost' : משקל الوزن. Súly : Teža : Тегло : Raskus Svoris Svars</p>	15,3 kg
---	--	--	----------------





	<p>Porter des lunettes de sécurité : Wear protective eyewear : Schutzbrille tragen : Llevar puestas gafas protectoras : Portare de gli occhiali di sicurezza : Utilizar óculos de segurança : Draag een veiligheidsbril : Φορέστε Προστατευτικά γυαλιά : Zakładać okulary ochronne : Käytä suoja-laseja : Använd skyddsglasögon : Der skal benyttes sikkerhedsbriller : Purtati ochelari de protectie :</p>	<p>Наденьте защитные очки : Güvenlik gözlükleri takın : Používejte bezpečnostní brýle : Noste ochranné okuliare : תווחיטב יפקשמ ביכרהל אנ חמל נזפארט וציאי. Viseljen védőszemüveget : Nositi zaščitna očala : Да се използват защитни очила : Kandke kaitseprille Nešioti apsauginius akinius Valkät aizsargbrilles</p>	X
	<p>Porter un masque anti-poussière: Wear a dust mask : Staubschutzmaske tragen : Llevar puesta una careta de protección contra el polvo : Indossare una mascherina anti-polvere : Utilizar uma máscara anti-poeira : Draag een stofmasker : χρήση προστατευτική μάσκα : Zakładać maskę przeciwpyłową Käytä pölysuojust : Bär mask mot damm : Der skal benyttes beskyttelsesmaske mod støv: Purtati mască anti-praf :</p>	<p>Наденьте респиратор : Toza karşı maske takın : Používejte masku proti prachu : Noste ochrannú masku proti prachu : קבא דגג הכסמ שובחל אנ ליס צנאע מצראס ללגיאר. Viseljen porvédő maszkot Nositi zaščitno masko proti prahu: Да се използва защитна маска : Kandke tolmumaski. Dëvëti respiratorių Valkät aizsarg masko pret putekļiem</p>	X
	<p>Porter une protection auditive: Wear hearing protective equipment: Gehörschutz tragen: Llevar puesta una protección auditiva: Portare una protezione uditiva: Utilizar uma protecção auditiva: Draag gehoorbeschermers: Φορέστε Προστατευτικά ακουστικά Zakładać słuchawki ochronne Käytä kuulosuojaimia: Bär hörselskydd: Der skal benyttes hørevern: Purtati căști de protectie auz:</p>	<p>наденьте средства звуковой защиты: İşitsel koruma aleti takın: Používejte ochranu sluchu: Noste ochranné slúchadlá: יש ל הרכיב הגנת שמיעה ליס חודצה צמצ הצרעיגי. Viseljen fülvédőt Nositi zašitno ušes: Да се използва слухови защитни средства: Kandke kõrvakaitset Nešioti apsaugā nuo triukšmo valkät dzirdes aizsarglīdzekļi</p>	X
	<p>Porter des gants : Use rubber gloves : Schutzhandschuhe tragen : Llevar guantes de protección : Indossare i guanti di protezione : Utilizar luvas de protecção : Draag veiligheidshandschoenen : χρήση προστατευτικών γαντιών : Używać rękawic ochronnych : Käytä suoja-käsineitä : Använd skyddshandskar : Der skal benyttes handsker : Purtati mănuși :</p>	<p>Наденьте перчатки : Eldiven takın : Noste rukavice : Noste rukavice : תופכ שובלל אנ ליס צנאזאט. Viseljen kesztyű t Nositi rokavice: а се използват предпазни ръкавници : Kandke kindaid Muvëti pirštines Valkät cimdus</p>	X





Niveau de puissance acoustique : Acoustic power level : Schallleistungspegel : Nivel de potencia acústica : Livello di potenza acustica: Nivel de potência acústica: Niveau akoestisch vermogen : Σπίθμη Ονομαστική Θορόβου : Poziom mocy akustycznej : Käytä suojalaseja : Ljudstyrkenivå : Lydstyrke : Nivel putere acustică :	уровень мощности звука : Akustik basınc seviyesi : Hladina zvukového výkonu: Hladina zvukového výkonu: רמת כוח אקוסטי. مستوى الضجيج. a hangnyomás szintje : Nivo akustične jakosti : Равнище на вибрации : Helivõimsuse nivoo Triukšmo lygis Akustiskās jaudas līmenis	92 dB (A)
--	--	------------------

Niveau de pression acoustique : Acoustic pressure level : Schalldruckpegel : Nivel de presión acústica : Livello di pressione acustica : Nivel de pressão acústica : Niveau akoestische druk : Σπίθμη Θορόβου : Poziom mocy akustycznej : Käytä kuulosuojaimia: Ljudtrycksnivå : Lydtryk : Nivel presiune acustică :	Уровень акустического давления. : Akustik basınc seviyesi : Hladina akustického tlaku : Hladina akustického tlaku : רמת לחץ אקוסטי. مستوى الضغط السمعي. A hangnyomás szintje : Nivo akustičnega pritiska: Равнище на акустично налягане : Helirõhu nivoo Akustinio spaudimo lygis Akustiskā spiediena līmenis	79 dB (A)
--	--	------------------

NIVEAU SONORE D'EMISSION:	A VIDE
Pression acoustique LpA poste opérateur	79 dB
Incertitude	3
Puissance acoustique LWA	92 dB
Incertitude	3



Valeurs déterminées suivant le code d'essai de l'annexe B de la norme EN 61029-1 avec emploi des normes de base ISO 11201 et ISO 3744.

Les niveaux de pression acoustique obtenus in situ dépendent:

- Des niveaux réels de la machine considérées, en prenant en compte les incertitudes déclarées;
- Du local et de l'installation de la machine. Préférez une pièce dont l'acoustique est plus feutrée. Evitez les pièces vides à grande résonance. Placez vous auprès d'une fenêtre le cas échéant.
- Des outils montés, des pièces travaillées, des réglages choisis,...











	<p>Conformité européenne Conforms to EC standards : CE-Konformität : Cumples con las directivas CE : Conforme alle norme CE : Conforme às normas CE : Voldoet aan de EG-normen : Συμφώνω με τα πρότυπα Zgodność z normami CE : EU-standardien mukainen : EU-standardien mukainen : Overholder EU standarderne : Conform cu normele europene:</p>	<p>соответствие европейским стандартам: Avrupa uygunluk : evropská shoda : európska dohoda : התאמה לתקנים האירופיים مطابق للمواصفات الأوروبية. evropska ustreznost : európai megfeleléség : Съответствие с европейските норми : Euroopa Liidu vastavusmärk Europinių normų atitikima Atbilstība Eiropas standartiem</p>	X
	<p>Lire les instructions avant usage : Read the instructions before use : Vor Einsatz des Geräts Anweisung lesen : Léase las instrucciones antes de usar : Leggere le istruzioni prima dell'uso : Ler as instruções antes da utilização : Lees voor het gebruik de instructies : Διαβάστε τις οδηγίες χρήσης : Zapoznać sięz instrukcją przed użyciem : Lue ohjeet ennen käyttöä : Läs anvisningarna före användning : læs instruktionerne før brug Înainte de utilizare, citiți instrucțiunile :</p>	<p>Внимательно прочитайте следующие инструкции : Kullanmadan talimatları okuyunuz : Pozorně si přečtěte následující pokyny : Pred použitím si prečítajte pokyny : זרם חילופי اقرأ التعليمات قبل الاستخدام. használat előtt olvassuk el az utasítást : Pred uporabo preberite ustreznna navodila : Прочетете указанията за употреба : Enne kasutamist lugege instruksiooni Prieš naudojimą perskaityti instrukciją izlasīt instrukcijas pirms lietošanas</p>	X
	<p>Danger : Danger : Gefahr : Peligro : Pericolo : Perigo : Gevaar : Κίνδυνος : Niebezpieczeństwo : Vaara : Fara : Fare : Pericol :</p>	<p>Опасно : Tehlike : Nebezpečí : Nebezpečnstvo : סכנה. خطر. Vesély : Nevarnost: Опаснот : Oht Pavojus Bīstamība</p>	X



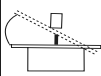

		150 mm
		1400 min ⁻¹
		275 min ⁻¹
		914 x 100 mm
		0 -> 45°
		125 x 190 mm





	<p>Soumis à recyclage Subjected to recycling Sujeto a reciclaje Sottoposti a riciclaggio Sujeitos à reciclagem Não deite no lixo : Niet wegwerpen : Μην την πετάτε : Nie wyrzucasz : Älä heittää pois luontoon : Batteriet får inte kastas : Bortkast det ikke : Nu le auncati :</p>	<p>Не выбрасывайте в мусорный ящик Atmayiniz : Nevyhazujte je do bežného odpadu : Neodhadzovat : אין לזרוק סוללות فلا ترمدها لهذا في القمامة. ne mečitel Ne odvřizte ga/jih vstran : Не го изхвърляйте : Ärge visake seda minema : Nemetykíte : Nemest :</p>	X
---	--	--	---

FR-Recyclage des déchets:

Les outils, accessoires et leur emballages doivent suivre une voie de recyclage adaptée. Conformément aux directives Européenne 2002/96/CE et 91/157/CEE, les composants d'un produit doivent être séparés, collectés, recyclés ou éliminés en conformité avec les réglementations environnementales en vigueur. Les appareils, batteries, piles, huiles, emballages devront être déposés dans les systèmes d'élimination des déchets spéciaux tels que déchetteries. Renseignez vous auprès de votre commune pour connaître l'organisme le plus proche à même de retraiter ou de collecter ces déchets.

EN-Waste recycling:

The tools, accessories and their packaging must use an appropriate recycling channel. In compliance with European Directives 2002/96/EC and 91/157/EEC, a product's components must be separated, collected, recycled or eliminated in accordance with the environmental regulations in force. The appliance, batteries, oils and packaging must be deposited in the special waste elimination systems such as the waste collection centres. Ask your commune for information on the nearest organisation in a position to reprocess or collect this waste

ES-Reciclado de los residuos:

Las herramientas, los accesorios y los envases tienen que seguir la vía de reciclaje adecuada. En virtud de las directivas europeas 2002/96/CE y 91/157/CEE, los componentes de un producto deben separarse, recogerse, reciclarse o eliminarse de acuerdo con las regulaciones medioambientales vigentes. Los aparatos, baterías, pilas, aceites, envases deberán llevarse a los centros de eliminación de residuos especiales tales como los ecoparques. Pedir información al municipio para conocer el centro más cercano apto para reciclar o recoger dichos residuos.

IT-Riciclaggio dei rifiuti:

Gli apparecchi, i loro accessori ed imballaggi devono essere sottoposti ad un processo di riciclaggio appropriato. In conformità con le direttive europee 2002/96/CE e 91/157/CEE, i componenti di un prodotto devono essere separati, raccolti, riciclati o smaltiti in conformità con le normative ambientali in vigore. Gli apparecchi, le batterie, le pile, gli oli, gli imballaggi dovranno essere conferiti nei sistemi di smaltimento dei rifiuti speciali come le isole ecologiche. Informarsi presso il proprio comune per sapere qual è l'ente più vicino in grado di fare il trattamento o la raccolta differenziata di questi rifiuti

PT-Reciclagem do lixo:

As ferramentas, acessórios e suas embalagens devem seguir um canal de reciclagem adaptado. Conformemente às diretivas europeias 2002/96/CE e 91/157/CEE, os componentes de um produto devem ser separados, recolhidos, reciclados ou eliminados de acordo com as regulamentações ambientais em vigor. Os aparelhos, baterias, pilhas, óleos e embalagens deverão ser depositados nos sistemas de eliminação de detritos especiais, tais como unidades de triagem de detritos. Informar-se junto ao seu concelho municipal para conhecer o órgão mais próximo habilitado a evacuar ou recolher estes detritos.





CP 150

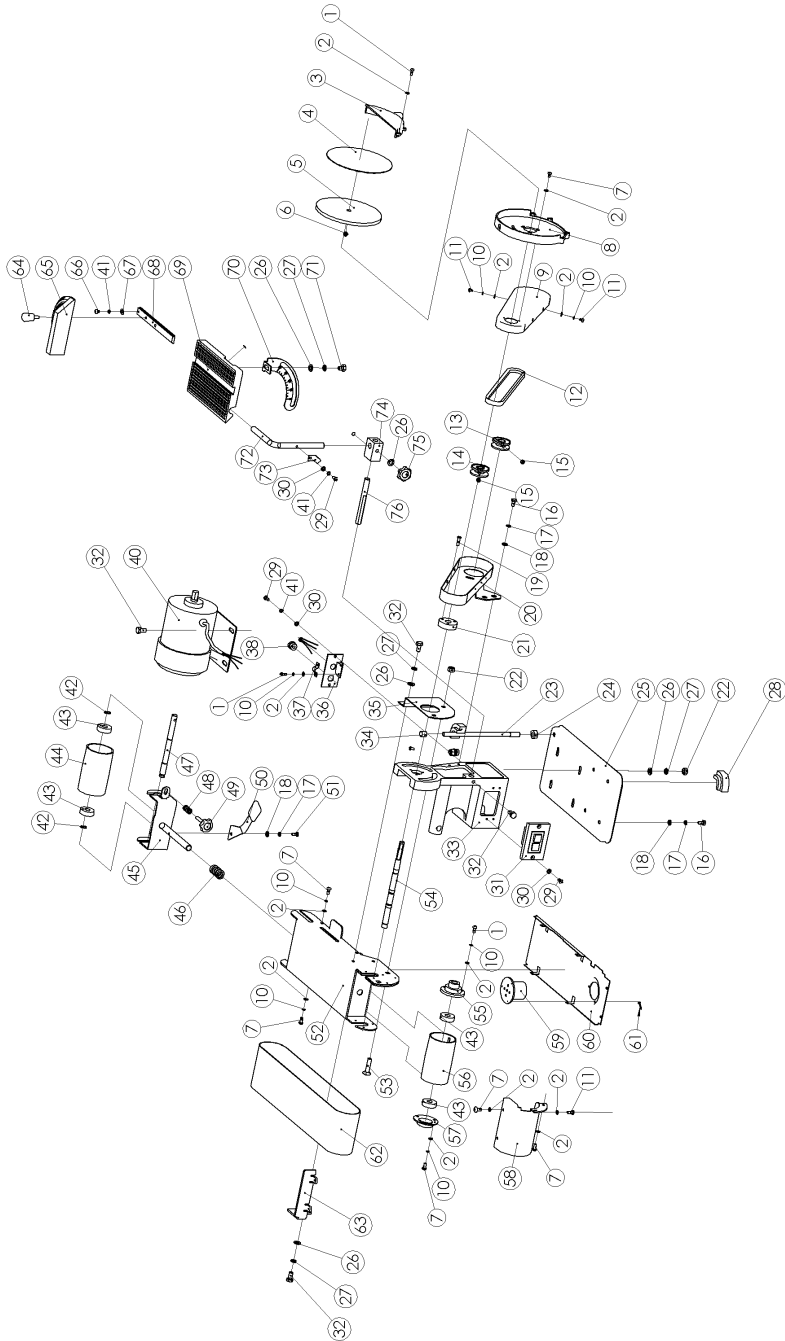

VERKLARING VAN OVEREENSTEMMING
DECLARATION DE CONFORMITE
KONFORMITÄSERKLÄRUNG
DECLARAÇÃO DE CONFORMIDADE
OM ÖVERENSSTÄMMESE
Overensstemmelseserklæring

Declarație de conformitate
 Декларация соответствия
 UYGUNLUK BEYANI
 Prohlášení shody
 Декларация за съответствие с нормите

DECLARACION DE CONFORMIDAD
DICHIAZIONE DI CONFORMITA
DECLARATION CONFORMITY
DEKLARACJA ZGODNOSCI Z NORMAMI
VAATIMUSTENMUKAISUUSVAKUUTUS
Δήλωση συμμόρφωσης/συμμόρφωση

Vyhlasenie zhody
 הצהרת תואמת
 التصريح بالخطابفة
 Egyezőségi nyilatkozat
 Izjava o skladnosti

Ondergetekende,
 Le soussigné,
 Der Unterzeichner,
 O abaixo assinado,
 Undertecknad,
 Долуподписаният
 Undertegnede
 Subsemnatul,
 Я, нижеподписавшийся,
 İmzalayan,
 Níže podepsaný,

Personne autorisée à constituer le dossier technique:
Christophe HUREL

El suscrito,
 Il sottoscritto,
 The undersigned,
 Nínej podpísany
 Allekirjoittanut,
 Ουπτογεγραμμένος
 Nižšie podpísaný
 הנתנת מטעמי
 الجوق ع انزاه
 Alulírott,
 Podpisani,



FAR GROUP EUROPE
 192 Avenue Yves Farge
 37700 Saint-Pierre-des-Corps
 FRANCE

Verklaart hiermede dat,
 Déclare par la présente que,
 Erklärt hiermit daß,
 Declara pela presente que,
 Förklarar härmed att
 Заявлява с настоящото
 erklærer hermed, at
 Declar prin prezenta că,
 настоящим подтверждаю, что
 Mecvut belgeyle beyan ediliyor ki,
 tímto prohlašuje, že,

Declara por la presente, que,
 Dichiare che,
 Declares that,
 OÖwiadcza niniejszym, że
 Ilmoitetaan täten että,
 Δηλώνει με την Παράστα
 týmto vyhlasuje, že
 מצהיר בזה כי
 يصدرح إسنادا على ذلك
 kijelentem, hogy a készülék Izjavlja da,

Combiné Ponceur / Belt and disc sander / Combischleifer / Lijadora Combinada / Levigatrice combinata / Lixadeira / Bandschuurachine et schuurschijf / Παλι υδρο μ.κ.ο.σ / Kombinacja szlifierek / Lautas/nauhahiomakone / Bandslipmaskin med sliptalrik / Bandslipmaskin med sliptalrik / Kombinert slibemaskine / Mašinã de șlefuit combinatã / Комбинированный шлифовальный станок / Bant ve diskli kombine zmpara makinesi / Kombinovaná bruska / Kombinovaná bruska / תיתילכת-בר שוטיל תנוכמ / شيراند لقص قلا / Kombinált csiszoló / kombiniran polirni stroj / Kombineeritud lihviija / Kombinuta (mišri) grěžimo mašina / Kombinētã slīpmašīna

code
FARTOOLS ONE / 113200 / CP 150 / MM1510

In overeenstemming is met en Voldoet aan EG richtlijnen,
 Est conforme et satisfait aux normes CE,
 Den folgenden EU-Bestimmungen entspricht,
 Respeita e está em conformidade com as normas CE,
 Överensstämmer med och uppfyller EG-standarder,
 Съответства и отговаря европейските норми
 er i overensstemmelse med og overholder EU standarderne
 Este conform și satisfac normele CE
**полностью соответствует и удовлетворяет
 требованиям стандартов ЕС**
 CE şartlara uygundur,
 odpovídá normám ES.

Cumple con la directivas de la CE,
 È conforme alle direttive CEE,
 Complies with the EEC standards,
 Odpowiada normom UE,
 Täyttää EU-vaatimukset,
 Είναι συμμόρφων και ανταποκρίνεται στα Πρότυπα CE
 zodpovedá normám ES.
 מתאים ועונה לתקני CE
 بأن الجهاز يطابق و يلبي معايير مجموعة الدول الأوروبية
 kielégíti a CE szabványok előírásait.
 Je v skladu z in izpolnjuje norme Evropske skupnosti.

2006/42/EC, 2014/30/EU 2015/863/EU
 2011/65/EU
 EN61029-1:2009+A11:2010
 EN55014-1:2017
 EN55014-2:2015
 EN61000-3-2:2014
 EN61000-3-3:2013
 EN ISO 12100:2010

Christophe HUREL,
 Président Directeur Général
 04/06/2018
 Fait à St. Pierre-des-Corps



Plaques signalétiques - naamplaatjes - placas de identificación - placas de identificação - targhette - machine labels

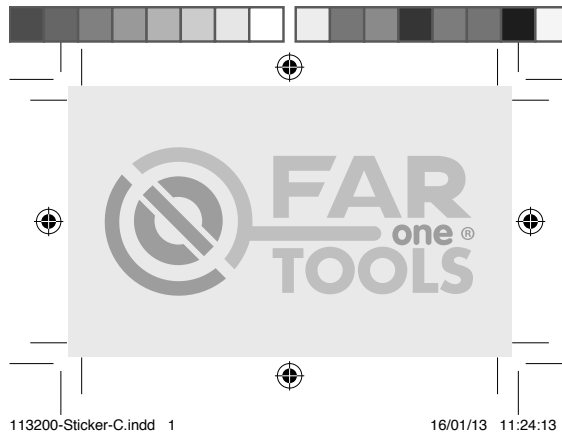
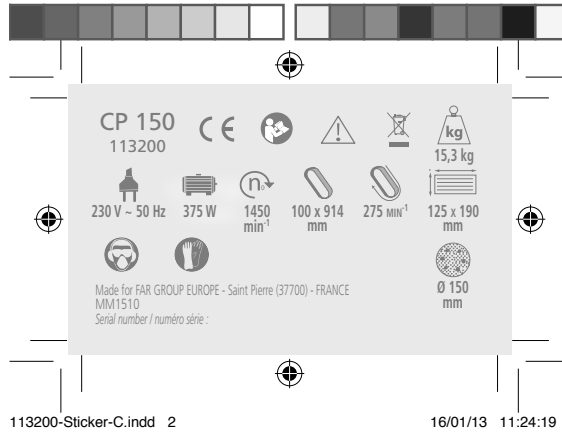



FR. GARANTIE

Cet outil est garanti contractuellement contre tout vice de construction et de matière, à compter de la date de vente à l'utilisateur et sur simple présentation du ticket de caisse. La garantie consiste à remplacer les parties défectueuses. Cette garantie n'est pas applicable en cas d'exploitation non conforme aux normes de l'appareil, ni en cas de dommages causés par des interventions non autorisées ou par négligence de la part de l'acheteur. La garantie ne s'applique pas sur les dommages causés par une défaillance de l'outil.

DE. GARANTIE

Die Garantiezeit für dieses Gerät in bezug auf Konstruktions- und Materialfehler beträgt lt. Vertrag bei Vorlage des Kassenbons. Die Garantieleistung besteht im Ersatz schadhafter Teile. Die Garantie erlischt bei einem Einsatz des Geräts, der nicht normentsprechend ist, bei Schäden, die auf unsachgemäße Eingriffe zurückzuführen sind bzw. bei Nachlässigkeit seitens des Käufers. Die Garantie erstreckt sich nicht auf Schäden, die auf Fehlfunktionen des Geräts zurückzuführen sind.

IT. GARANZIA

Quest' attrezzo è garantito per contratto contro qualsiasi difetto di costruzione e di materia, a partire dalla data di vendita all'utente e su semplice presentazione dello scontrino. La garanzia consiste nel sostituire le parti difettose. Questa garanzia non è applicabile in caso di sfruttamento non conforme alle norme dell'apparecchio, né in caso di danni causati da interventi non autorizzati o da negligenza da parte dell'acquirente. La garanzia non si applica ai danni causati da un'avaria dell'attrezzo.

EN. GARANTEE

This tool is guaranteed, in writing, against any defect in manufacture or parts from the date of sale, upon simple presentation of the sales slip. The guarantee is limited to the replacement of faulty parts. This guarantee is not applicable in the event of usage which is not conform with the intended usage of the apparatus, nor in the event of damage caused by unauthorised servicing or negligence on behalf of the purchaser. This guarantee does not apply to any damage caused by the failure of this tool.

ES. GARANTIA

Esta herramienta se garantiza contractualmente contra todo defecto de construcción y materia, a partir de la fecha de venta a l' usuario y sobre simple presentación del recibo de caja. La garantía consiste en sustituir a las partes defectuosas. Esta garantía no es aplicable en caso de explotación no conforme a las normas del aparato, ni en caso de daños causados por intervenciones no autorizadas o por negligencia por parte del comprador. La garantía no se aplica sobre los daños causados por un fallo del herramienta.

NL. GARANTIE

Dit gereedschap heeft een garantie tegen constructiefouten en materiaaldefecten, die geldig is vanaf de aankoopdatum door de gebruiker, op vertoning van de kassabon. De garantie betreft de vervanging van de defecte onderdelen. Deze garantie is niet van toepassing indien het apparaat niet volgens de normen gebruikt is, noch in geval van schade veroorzaakt door oneigenlijk gebruik of nalatigheid van de koper. De garantie is niet van toepassing op schade voortvriend uit een defect van het gereedschap.

PT. GARANTIA

Esta ferramenta tem uma garantia contratual contra qualquer defeito de construção e de material, a partir da data de venda ao utilizador e sobre simples apresentação do talão da caixa. A garantia consiste em substituir as partes defeituosas. Esta garantia não é aplicável no caso de exploração não conforme às normas do aparelho, nem em caso de danos causados pelas intervenções não autorizadas ou por negligência da parte do comprador. A garantia não se aplica para os danos causados por uma falha da ferramenta.

EL. Εγγύηση

Το εργαλείο αυτό φέρει συμβατική εγγύηση για οποιoδήποτε ελάττωμα κατασκευής απ'ο την ημερομηνία Π'ωλησης στο χ'ρήστη. με απλή Προσκ'ομιση της απ'ο'οειξης αγορ'αξ. Η εγγύηση απ'οτελείται απ'ο την αντικατ'ασταση των ελαττωματικ'ων τμημ'ατων. Η Παρο'υσα εγγύηση σ'ειν εφαρμ'οζεται σε Περίπτωση χ'ρήσης μη σ'υμφωνηξ με τα Πρ'οτυπα της συσκευ'ης. η σε Περίπτωση ζημ'ιαξ Που Προκλ'ηθηκε απ'ο μη εγκεκριμ'ενη επ'εμβαση 'η απ'ο αμ'ελεια του αγοραστ'η. Η εγγύηση 'οεν εφαρμ'οζεται στις ζημ'ειξ Που Προκαλο'υνται απ'ο βλ'αβη του εργαλει'ου Σταυρο'ι κεν'ο Δαστημο- Παρ'εμβυσμα

PL. GWARANCJA

Narz'dzie jest obj'ete gwarancją na wszelkie wady konstrukcyjne i materia[owe, licząc od daty sprzedania u'ytownikowi i po okazaniu paragonu kasowego. Gwarancją obejmuje wymian' cz'łci wybrakowanych. Gwarancją nie znajduje zastosowania w przypadku u'ytowania niezgodnego z normami urz'adzenia, ani w przypadku szk'od spowodowanych dzia[aniami niezadowolonymi lub zaniebdaniami ze strony nabywcy. Gwarancją nie obejmuje szk'od powsta[lych z powodu upadku urz'adzenia.

SV. GARANTI

Detta verktyg har en avtalsenlig garanti mot konstruktions- och materialfel, fr'ån och med tidpunkten för anv'andarens inköp och genom uppv'isning av kassakvittot. Garantin består i att ersätta de bristfälliga delarna. Denna garanti gäller inte om anv'andningen inte motsvarar apparatens standarder, inte heller vid skador som orsakas av ej tillåtna ingrepp eller på grund av köparens vårdslöshet. Garantin gäller inte förskador som orsakats av att verktyget fungerat bristfälligt.

FI. TAKUU

Tämän laitteen takuu on voimassa sopimuksenmukaisesti kattaen kaikki rakenne- ja materiaaliiviat lukien ostopäivästä kassakuittia vastaan. Takuu sisältää viallisten osien korvaamisen. Takuu ei korvaa ohjeidenvastaista käyttöä eikä valtuuttamattomien henkilöiden käsittelystä tai ostajan huolimattomuudesta aiheutuneita vahinkoja. Takuu ei vastaa myöskään toimintahäiriöistä aiheutuneita vahinkoja.

BU. Гаранция

Този инструмент е под договорна гаранция срещу всякакъв дефект в изработката и използваните материали, считано от датата на продажба на потребителя и само срещу представяне на касовата бележка. Гаранционното обслужване се състои в замяна на дефектните части. Настоящата гаранция не е валидна когато апаратът се използва по начин, несъответстващ на стандарта за работа с него, както и в случай на щети, нанесени от неоторизирани лица, или вследствие на проявена небрежност от страна потребителя.

Гаранцията не покрива щети, произтекли вследствие на техническа неизправност на апарата.



DA. GARANTI

Dette værktøj er dækket af en garantikontrakt for konstruktions- og materialefejl, som gælder fra købsdatoen ved visning af kassebonen. Garantien består i at udfiske de defekte dele. Garantien dækker ikke fejl opstået som følge af anvendelse, som ikke overholder standarderne for apparatet, eller skader opstået ved ikke autoriserede indgreb eller sløsethed fra brugerens side. Garantien dækker ikke skader opstået, fordi værktøjet har svigtet.

RO. GARANȚIE

Acest aparat este garantat din punct de vedere contractual împotriva tuturor viciilor de construcție și de material, începând de la data vânzării lui către utilizator și la simpla prezentare a bonului de casă. Garanția constă în înlocuirea componentelor defecte. Această garanție nu se aplică în cazul exploatarei în alt mod decât cel recomandat de normele aparatului și nici în caz de stricăciuni provocate de intervenții neautorizate sau prin neglijența cumpărătorului. Garanția nu se aplică asupra pagbelor cauzate de o defecțare a aparatului.

RU. ГАРАНТИЯ

Данное изделие обладает имеющей силу контракта гарантией, покрывающей все возможные дефекты изготовления и материала. Гарантия вступает в силу с даты продажи изделия пользователю, для этого достаточно сохранить и предъявить полученный в кассе чек. Гарантия обязывает изготовителя заменить дефектные части изделия. В случае не соответствующего нормам использования изделия, несанкционированного демонтажа или ремонта или небрежного обращения действие гарантии прекращается. Гарантия не покрывает ущерба, возникшего в результате сбоев в работе изделия.

TU. GARANTI

Bu araç, satış tarihinden itibaren, kullanıcının sadece vezne alındısını sunmasıyla tüm üretime ve malzeme hatasına karşı garantilidir. Garanti eksik olan kısımları değiştirmek içinidir. Bu garanti aracın şartlarına uygun olmayan işleme durumunda, izin verilmeyen kullanımlardan kaynaklanan hasarlarda veya alıcının isteği durumunda uygulanmaz. Garanti malzemenin bir eksikliğinden meydana gelen bir zararda uygulanmaz.

CS. ZÁRUKA

Pro tento nástroj platí smluvní záruka na všechny výrobní a materiálové vady od data prodeje uživateli a na základě předložených pokladničního bloku. Záruka spočívá ve výměně vadných částí. Tato záruka neplatí v případě použití přístroje, které neodpovídá normám, ani v případě škod způsobených nepovolenými zásahy nebo nedbalostí ze strany kupujícího. Záruka se nevztahuje na škody způsobené závadou nástroje.

SK. ZÁRUKA

Pre tento nástroj platí zmluvná záruka na všetky výrobné a materiálové chyby od dátumu predaja užívateľovi a na základe predloženia pokladničného bloku. Záruka spočíva vo výmene chybných častí. Táto záruka neplatí v prípade použitia prístroja, ktoré nezodpovedá normám, ani v prípade škôd spôsobených nepovolenými zásahmi alebo nedbalosťou zo strany kupujúceho. Záruka sa nevzťahuje na škody spôsobené poruchou nástroja.

HE. אחריות

הי עכלכי זה חלה אחריות לפי חוזה מפני כל לקויי בייצור או בחומר, החל מיום המכירה למשתמש עם הצגת חשבונית קופה. האחריות-משמעה החלף תחלקם הלקויים אחריות זו אינה חלה במקרה של שימוש במכשיר שאינו מתאים לתקנים ובמקרה של נזק שנגרם על ידי התערבותי תללא סמכות או על ידי רשלנות מאת הקונה. האחריות אינה חלה על נזק שנגרם על ידי תקלה בכלי.

AR. الضمان

إن هذه العدة مضمونة تعاقدياً من أي عيب فني التصدي عوقفي المواد. إعتباراً من تاريخ البيع الى المستهلك عمل وبننا على مجرد تقديم بطاقة الضمان. يتعلّق الضمان فباي سبدال الأجزاء العاطلة لا يلاون هذا الضمان قابلاً للتطبيع في حالة الأيسخدام غير المطابق لمعايير الجهاز، ولا في حالة تعرضه لإحتلافتات ناتجة عن عمليات تعديل غير مصرح بها أو في حالة الإهمال من قبل المشتري لا ينطبق الضمان على الضرر الناتج عن غل

HU. GARANCIA

Entre a szerszámra szerződéses garanciát vállalunk bármilyen gyártási és anyaghiba felmerülése esetére, a fogyasztó részére történő eladás napjától számítva, a pénztári blokk egyszerű felmutatása ellenében. A garancia a hibás alkatrészek cseréjére terjed ki. Ez a garancia nem érvényes, ha a készülék nem rendeltetésszerűen használták, sem illetéktelen beavatkozások, vagy a vásárló hanyagsága okozta károk esetén. A garancia nem fedezi azokat a károkat, melyeket a szerszám hibás működése okozott.

SL. GARANCIJA

To orodje je z garancijsko pogodbo zaščiteno proti vsem napakam v izdelavi in v sestavnem materialu od datuma prodaje naprej in ta velja ob predložitvi blagajniškega računa. Garancija velja za zamenjavo delov z napako. Ta garancija ne velja za uporabo orodja, ki ni v skladu z normami, predpisanimi za omenjeno orodje in za primere okvar, ki nastanejo zaradi nedovoljenih posegov na orodju ali zaradi malomarnega rokovanja kupca. Garancija ne velja za škodo, ki jo lahko povzroči okvara orodja.

ET. GARANTII

See tööriist kuulub lepingu järgi garantiiremonti arvestades alates müümise päevast ja kasatšeki alusel kasutajale kõigi konstruktsiooni- ja materjalivigade puhul. Garantii seisneb defektsete osade väljavahetamisest. See garantii ei kehti aparaadi normide ebatavalise eiramise puhul ega ostja poolt keelatud viisil kasutamistest või hooletussejätmisest tulenevate kahjude korral. Garantii ei kehti seadme defektidest põhjustatud kahjude puhul.

LV. GARANTIJA

Šis prietaisais yra užtikrinamas kaip itin geros kokybės, nuo jo pardavimo datos iki jo panaudojimo, ir jam yra suteikiamas garantinis talonas. Garantijos metu galima pakeisti atsiradusius trumplataikius gedimus. Ši garantija netaikoma esant netinkamam naudojimui ar nesilaikant reikiam šio aparato vartojimo instrukcijų, tai pat pačiam pirkejuji jį sugadinus. Garantija taip pat netaikoma, prietaisais naudojant ne pagal paskirtį ir jį apgadinus.

LT. GARANTIJA

Šim darbarikam ir ligumā noteikta garantija visiem defektiem, kas saistās ar konstrukciju un materiālu, sākot ar pārdošanas datumu, kad mašīnu pārdo lietotājam un vienkārsī uzrādāt kases čeku. Garantija iekļauj bojāto daļu nomaiņu. Šī garantija nav derīga, ja aparāts nav lietots saskaņā ar drošības noteikumiem, ne gadījumos ja bojājumi radušies nesankcionētas iejaukšanās gadījumā vai arī pircēja nolaidības dēļ. Garantija nav derīga, ja bojājumi radušies darbarika defekta dēļ.