



FR	Visseuse à choc sans fil (Notice originale)
EN	Cordless impact wrench (Original manual translation)
DE	Schlagschrauber (Übersetzung aus dem Original-Anleitung)
ES	Atornillador de impacto (Traducción del manual de instrucciones original)
IT	Avvitatrice ad urti (Traduzione dell'avvertenza originale)
PT	Aparafusadora de percussão (Tradução do livro de instruções original)
NL	Slagschroevendraaier (Vertaling van de originele instructies)
EL	ΚΡΟΥΣΤΙΚΗ ΜΗΧΑΝΗ ΒΙΔΩΜΑΤΟΣ (ΜΕΤΑΦΡΑΣΗ ΑΠΟ ΤΙΣ ΠΡΩΤΟΤΥΠΕΣ ΟΔΗΓΙΕΣ)
PL	Wkrętarka udarowa (Tłumaczenie z oryginalnej instrukcji)
FI	Iskuruuvaava porakone (Käännös alkuperäisestä ohjeet)
SV	Slagskruvdragare (Översättning från originalinstruktioner)
BU	машина за завинтване с удар (Превод на оригиналната инструкция)
DA	Stødkruemaskine (Oversættelse fra oprindelige brugsanvisning)
RO	Mașină de înșurubat electro-pneumatică (Traducere din instrucțiunile originale)
RU	Ударный шуруповерт (Перевод с оригинальной инструкции)
TU	Soklu vidalayıcı (Orijinal talimatlar çeviri)
CS	Nárazová uzavíračka (Překlad z originálního návodu)
SK	Nárazový uzatvárač (Překlad z originálneho návodu)
HE	יטוחלא גרוב חותיפו הגרבהלה חדקמ) מברגה הלמים
AR	(يكي لصلأا تام كيل عتلا نم قم جرتلا) قباطحلا راش نم
HU	Elektropneumatikus csavarozó (Fordítás az eredeti utasítások)
SL	Udarni vijačnik (Prevod iz izvirnih navodil)
ET	Löökjõuga kruvikeeraja (Tõlge originaal juhiseid)
LV	Elektriskais skrūvgriezis (Tulkojumā no instrukcijas oriģinālvalodā)
LT	Smūginis tvirtinimo aparatas (Vertimas iš originalių instrukcijas)
HR	Bežični upravljački program č (Prijevod prema originalne upute)



## XF-Wrench Professional Machine



© FAR GROUP EUROPE

216036-A-20200824



[www.fartools.com](http://www.fartools.com)



**5 min**

Description et repérage des organes de la machine  
Description and location of machine parts

A



Contenu du carton  
Contents of box

C



# D

01

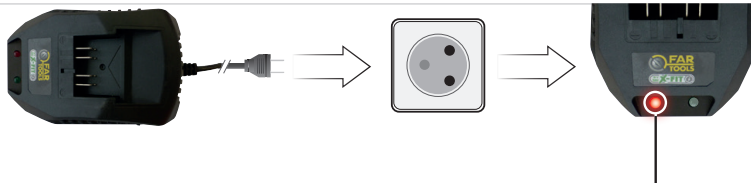

Rouge / Red / Rot / Rojo / Vermelho / Rosso

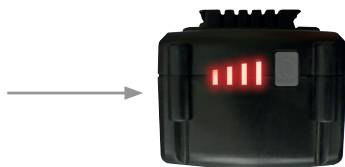

Vert / Green / Grün / Verde / Verde / Verde



40:00 = 1,5 Ah  
 80:00 = 3,0 Ah  
 100:00 = 4,0 Ah  
 120:00 = 5,0 Ah

02



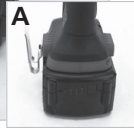
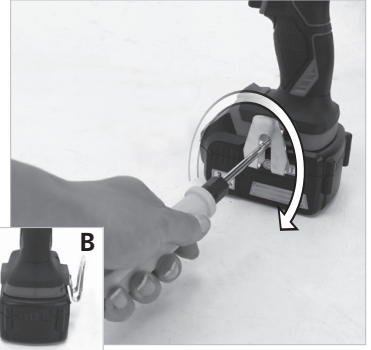
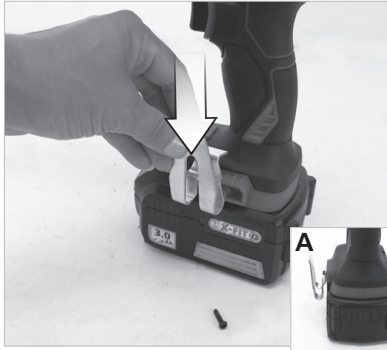
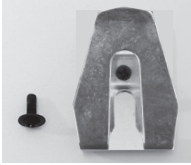

Fonctionnalité  
de la machine  
Functions  
of the machine

E

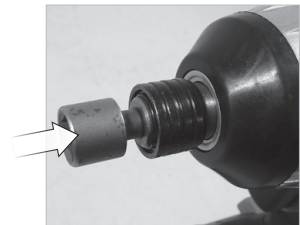
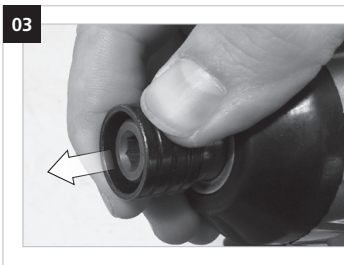
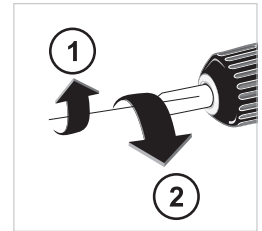
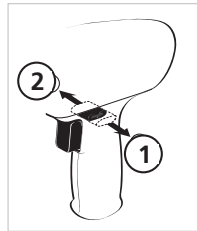
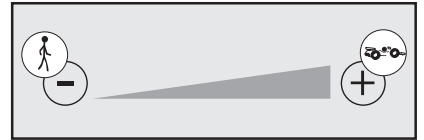
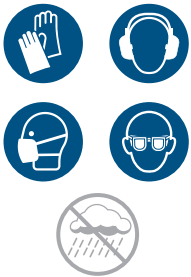

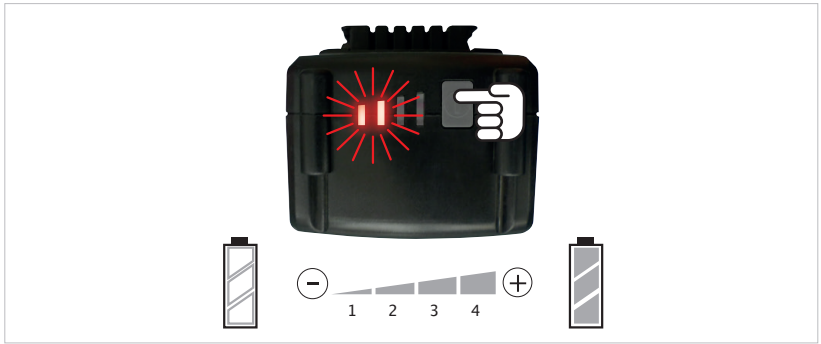

**216015:**  
 Batterie 18 Volts - 1,5Ah  
 Batterij 18 V - 1,5 Ah  
 18 Volts - 1,5Ah battery  
 Batteria 18 V - 1,5Ah



**216019:**  
 Batterie 18 Volts - 5,0 Ah  
 Batterij 18 V - 5,0 Ah  
 18 Volts - 5,0 Ah battery  
 Batteria 18 V - 5,0 Ah



**216017:**  
 Chargeur + Batterie 18 Volts - 1,5 Ah  
 Batterij 18 V - 1,5 Ah  
 18 Volts - 1,5 Ah battery  
 Batteria 18 V - 1,5 Ah



**216016:**  
 Batterie 18 Volts - 4Ah  
 Batterij 18 V - 4 Ah  
 18 Volts - 4Ah battery  
 Batteria 18 V - 4Ah



**216035:**  
 Chargeur + Batterie 18 Volts - 5,0Ah  
 Batterij 18 V - 5,0 Ah  
 18 Volts - 5,0 Ah battery  
 Batteria 18 V - 5,0 Ah



**216018:**  
 Chargeur + Batterie 18 Volts - 4,0Ah  
 Batterij 18 V - 4,0 Ah  
 18 Volts - 4,0 Ah battery  
 Batteria 18 V - 4,0 Ah



# Utilisation / Use / Utilização / Utilisacion / Utilizzazione

Une visseuse à choc permet le vissage et le dévissage d'ensembles boulonnés (assemblage de structure métallique, pose de bardages ou dépannage mécanique...)

Son principe de fonctionnement réside dans une succession de chocs portés sur l'axe de support de douille, provoquant un serrage (ou desserrage) important, particulièrement utile pour des boulons «grippés».

Force de serrage : 150 N/m

## **Fonction déblocage :**

- Utilisez si nécessaire une clé pour maintenir le contre écrou.

Pour un déblocage de visseries excessivement serrées ou rouillées, desserrez préalablement à l'aide d'une clé.

## **Fonction blocage :**

- La visseuse à choc permet de visser de façon rapide et sûre des ensembles boulonnés.

Néanmoins, Certains serrages de sécurité (roues de véhicules, organes mécaniques...) doivent être terminés manuellement à l'aide de clés standard, plate ou dynamométrique).

An impact wrench enables to screw and unscrew bolted sets ( assembling of metal structures, putting claddings or mechanical repairing...)  
This machine operates thanks to a succession of shocks, which are made on socket support axis and which also bring about an important screwing (or unscrewing), particularly useful for seized bolts.

Force of tightening : 150 N/m

## **Function unblocking :**

-If it's necessary, use a wrench in order to support lock nut.

Concerning the unblocking of excessively screwed or rusty screw, unscrew before hand with a wrench.

## **Function blocking :**

-The impact wrench enables to screw rapidly and safety bolted sets. Nethertheless, some safety tightenings ( wheels of vehicules ), mechanicals components ) must be finished manually thanks to standard flat or torque wrenches.

Uma chave de impacto de aperto e desaperto que poderá ser aplicada em variadíssimas soluções (montagem de estruturas metálicas, desempanagem mecânica, desaperto de rodas de automóveis, etc...)

A base do seu funcionamento reside numa sucessão de impactos levados sobre o eixo do veio, provocando assim o aperto ou desaperto bastante forte. Particularmente importante para parafusos onde a força de aperto ou desaperto é importante. 150 N/m

## **Função de desbloqueio :**

Em caso de necessidade de uma contra força de desbloqueio, utilizar uma chave manual para o efeito. Para um desbloqueio de parafusos excessivamente apertados ou presos, utilizar primeiro uma chave manual para aliviar a pressão.

## **Função de bloqueio :**

Esta chave de impacto permite apertar de forma rápida e eficaz conjuntos de parafusos determinado a força máxima de paragem de aperto. No entanto, e para certos casos (desempanagem de veículos) em que será necessário um aperto métrico do parafuso, aconselhamos a terminar o trabalho com uma chave manual ou uma chave dinométrica.

Un destornillador de choque permite el atornillamiento y el destornillamiento global empernado (montaje de estructura metálico, instalación de elevaciones o reparación mecánica).

Su principio de funcionamiento reside en una sucesión de choques referidos al eje de apoyo de cubierta, causando una sujeción (o aflojamiento) importante, especialmente útil para pernos «agarrotados».

Fuerza de sujeción : 150 N/m

## **Función desbloqueo:**

Utilizar en caso necesario una llave para mantener los contra tuerca.

Para un desbloqueo de tornillos en exceso apretadas u oxidadas, aflojar previamente con ayuda de una clave.

## **Función bloqueio**

El destornillador de choque permite atornillar de una manera rápida y segura los conjuntos empernados. Sin embargo, algunas sujeciones de seguridad (ruedas de vehículos, órganos mecánicos...) deben terminarse manualmente con ayuda de llaves normales, planas o dinamométricas.

Avvitatore a impulsi Permette l'avvitamento e la svitura di bulloni (assemblaggio di strutture metalliche, svitura di bulloni per cerchioni...).

Coppia di serraggio : 150 Nm .....

**Funzione sbloccaggio :** Utilizzate, se necessario una chiave per bloccare il dado. Per sbloccare bulloni eccessivamente serrati o arrugginiti, allentateli con una chiave.

**Funzione bloccaggio :** l'avvitatore permette di avvitare in modo rapido e sicuro tuttavia, alcuni serraggi di sicurezza (ruote di veicoli, organi meccanici...) devono essere serrati manualmente con chiavi dinamometriche.

		ø 6,35 mm - 1/4"
---	--	------------------

	<p>Vitesse à vide: No-load speed: Drehzahl unbelastet: Velocidad vacía: Velocità a vuoto: Velocidade no vácuo: Leerlaufdrehzahl: Ταχύτητα στο κενό: Prędkość bez bciążenia: Tyhjäkäyntinopeus Tomgångshastighet: Hastighed i ubelastet tilstand: Viteza în gol:</p>	<p><b>Скорость вращения на холостом ходу:</b> Boşalma hızı: Rychlost naprázdno: Rýchlost' pri chode naprázdno: מהירות ריק. السرعة على الفارغ. Üres sebesség: Prosti tek: <b>Скорост на празни обороти:</b> Kiirus tühikäigul Tuščio prietaiso greitis Tukšgaitas ātrums Brzina praznog hoda:</p>	0 - 2000 min-1
---	---	--	----------------

	<p>Vitesse à vide: No-load speed: Drehzahl unbelastet: Velocidad vacía: Velocità a vuoto: Velocidade no vácuo: Leerlaufdrehzahl: Ταχύτητα στο κενό: Prędkość bez bciążenia: Tyhjäkäyntinopeus Tomgångshastighet: Hastighed i ubelastet tilstand: Viteza în gol:</p>	<p><b>Скорость вращения на холостом ходу:</b> Boşalma hızı: Rychlost naprázdno: Rýchlost' pri chode naprázdno: מהירות ריק. السرعة على الفارغ. Üres sebesség: Prosti tek: <b>Скорост на празни обороти:</b> Kiirus tühikäigul Tuščio prietaiso greitis Tukšgaitas ātrums Brzina mirovanja:</p>	0-3000 Hit/min
---	---	---	----------------

		150 N. m
---	--	----------

	<p>Poids : Weight : Gewicht : Peso : Peso : Peso : Gewicht : Βάρος : Masa : Paino : Vikt : Vægt : Greutate :</p>	<p><b>Вес :</b> Ağırlık : Hmotnost : Hmotnost' : משקל الوزن. Súly : Teža : Тегло : Raskus Svaris Svars Težina:</p>	1,60 kg
---	--	--	---------





	<p> Lire les instructions avant usage :  Read the instructions before use :  Vor Einsatz des Geräts Anweisung lesen :  Léase las instrucciones antes de usar :  Leggere le istruzioni prima dell'uso :  Ler as instruções antes da utilização :  Lees voor het gebruik de instructies :  Διαβάστε τις οδηγίες χρήσης :  Zapoznać się instrukcją przed użyciem :  Lue ohjeet ennen käyttöä :  Läs anvisningarna före användning :  læs instruktionerne før brug  Înainte de utilizare, citiți instrucțiunile : </p>	<p> <b>Внимательно прочитайте следующие инструкции :</b>  Kullanmadan talimatları okuyunuz :  Pozorně si přečtěte následující pokyny :  Pred použitím si prečítajte pokyny :  זרם חילופי  قرأ التعلیمات قبل الاستخدام.  használat előtt olvassuk el az utasítást :  Pred uporabo preberite ustrezna navodila :  <b>Прочетете указанията за употреба :</b>  <b>Enne kasutamist lugege instruksiooni</b>  <b>Prieš naudojimą perskaityti instrukciją</b>  <b>izlasīt instrukcijas pirms lietošanas</b>  Prečitati upute prije uporabe: </p>	<b>X</b>
---	--	---	----------

	<p> Conformité européenne  Conforms to EC standards :  CE-Konformität :  Cumple con las directivas CE :  Conforme alle norme CE :  Conforme às normas CE :  Voldoet aan de EG-normen :  Συμφωνο με τα πρότυπα  Zgodność z normami CE :  EU-standardien mukainen :  EU-standardien mukainen :  Overholder EU standarderne :  Conform cu normele europene: </p>	<p> <b>соответствие европейским стандартам:</b>  Avrupa uygunluk :  evropská shoda :  európska dohoda :  התאמה לתקנים האירופיים  مطابق للمواصفات الأوروبية.  evropska ustreznost :  európai megfelelőség :  <b>Съответствие с европейските норми :</b>  <b>Euroopa Liidu vastavusmärk</b>  <b>Europinių normų atitikima</b>  <b>Atbilstība Eiropas standartiem</b>  Evropska sukladnost </p>	<b>X</b>
---	---	--	----------

	<p> Danger :  Danger :  Gefahr :  Peligro :  Pericolo :  Perigo :  Gevaar :  Κυδνός :  Niebezpieczeństwo :  Vaara :  Fara :  Fare :  Pericol : </p>	<p> <b>Опасно :</b>  Tehlike :  Nebezpečí :  Nebezpečenstvo :  .סכנה.  خطر.  Veszély :  Nevarnost:  <b>Опасност :</b>  <b>Oht</b>  <b>Pavojus</b>  <b>Bistamība</b>  <b>Opasnost:</b> </p>	<b>X</b>
---	---	--	----------

	<p>Porter des lunettes de sécurité : Wear protective eyewear : Schutzbrille tragen : Llevar puestas gafas protectoras : Portare de gli occhiali di sicurezza : Utilizar óculos de segurança : Draag een veiligheidsbril : Φορέστε Προστατευτικά γυαλιά : Zakładać okulary ochronne : Käytä suojalaseja : Använd skyddsglasögon : Der skal benyttes sikkerhedsbriller : Purtati ochelari de protectie :</p>	<p><b>Наденьте защитные очки :</b> Güvenlik gözlükleri takın : Používejte bezpečnostní brýle : Noste ochranné okuliare : תוהיטב יפקשמ ביכרהל אן חמל נזפארט וקאי. Viseljen védőszemüveget : Nositi zaščitna očala : <b>Да се използват защитни очила :</b> Kandke kaitseprille Nešioti apsauginius akinius Valkät aizsargbrilles Nosite zaštitne naočale:</p>	X
---	--	--	---

	<p>Porter un masque anti-poussière: Wear a dust mask : Staubschutzmaske tragen : Llevar puesta una careta de protección contra el polvo : Indossare una mascherina anti-polvere : Utilizar uma máscara anti-poeira : Draag een stofmasker : χρήση προστατευτική μάσκα : Zakładać maskę przeciwpyłową Käytä pölysuojust : Bär mask mot damm : Der skal benyttes beskyttelsesmaske mod støv: Purtati mască anti-praf :</p>	<p><b>Наденьте респиратор :</b> Toza karşı maske takın : <b>Používejte masku proti prachu :</b> Noste ochrannú masku proti prachu : קבא דגנ הכסמ שובחל אן לבס קזאע מפראש ללגבאר. Viseljen porvédő maszkot Nositi zaščitno masko proti prahu: <b>Да се използва защитна маска :</b> Kandke tolumaski. Dėvėti respiratorių Valkät aizsarg masku pret putekļiem Nosite masku za prašinu:</p>	X
---	--	---	---

	<p>Porter une protection auditive: Wear hearing protective equipment: Gehörschutz tragen: Llevar puesta una protección auditiva: Portare una protezione uditiva: Utilizar uma protecção auditiva: Draag gehoorbeschermers: Φορέστε Προστατευτικά ακουστικά Zakładać słuchawki ochronne Käytä kuulosuojaimia: Bär hörselskydd: Der skal benyttes høreværn: Purtati căști de protectie auz:</p>	<p><b>наденьте средства звуковой защиты:</b> Işıtsel koruma aleti takın: <b>Používejte ochranu sluchu:</b> Noste ochranné slúchadlá: יש ל הרכיב הגנת שמיעה לבס קזודה פרז הצרטיג. Viseljen fülvédőt Nositi zašito ušes: <b>Да се използва слухови защитни средства:</b> Kandke kõrvakaitset Nešioti apsaugą nuo triukšmo valkät dzirdes aizsarglīdzekli Nosite zaštitu sluha:</p>	X
--	---	--	---

	<p>Porter des gants : Use rubber gloves : Schutzhandschuhe tragen : Llevar guantes de protección : Indossare i guanti di protezione : Utilizar luvas de protecção : Draag veiligheidshandschoenen : χρήση προστατευτικών γαντιών : Używać rękawic ochronnych : Käytä suojakäsineitä : Använd skyddshandskar : Der skal benyttes handsker : Purtati mănuși :</p>	<p><b>Наденьте перчатки :</b> Eldiven takın : Noste rukavice : Noste rukavice : תופפכ שובלל אן לבס קפזאזא. Viseljen kesztyű t Nositi rokavice: <b>а се използват предпазни ръкавици :</b> Kandke kindaid Mūvēti pirštines Valkät cimdus Nosite rukavice:</p>	X
---	---	--	---

 <b>L<sub>pA</sub></b>	Niveau de pression acoustique : Acoustic pressure level : Schalldruckpegel : Nivel de presión acústica : Livello di pressione acustica : Nivel de pressão acústica : Niveau akoestische druk : Στάθμη Θορύβου : Poziom mocy akustycznej : Käytä kuulosuojaimia : Ljudtrycksnivå : Lydtryk : Nivel presiune acustică :	<b>Уровень акустического давления :</b> Akustik basınç seviyesi : Hladina akustického tlaku : Hladina akustického tlaku : ממת לחץ אקוסטי. مستوى الضغط السمعي. A hangnyomás szintje : <b>Nivo akustičnega pritiska:</b> <b>Равнище на акустично налягане :</b> <b>Helirõhu nivoo</b> <b>Akustinio spaudimo lygis</b> <b>Akustiskā spiediena līmenis</b> <b>Razina zvučnog tlaka:</b>	<b>92 dB (A)</b>

 <b>L<sub>wA</sub></b>	Niveau de puissance acoustique : Acoustic power level : Schalleistungspegel : Nivel de potencia acústica : Livello di potenza acustica: Nivel de potência acústica: Niveau akoestisch vermogen : Στάθμη Ονομαστική Θορύβου : Poziom mocy akustycznej : Käytä suojalaseja : Ljudstyrkenivå : Lydstyrke : Nivel putere acustică :	<b>уровень мощности звука :</b> Akustik basınç seviyesi : Hladina zvukového výkonu: <b>Hladina zvukového výkonu:</b> ממת כוח אקוסטי. مستوى الخرج ج. a hangnyomás szintje : <b>Nivo akustične jakosti :</b> <b>Равнище на вибрации :</b> <b>Helivõimsuse nivoo</b> <b>Triukšmo lygis</b> <b>Akustiskās jaudas līmenis</b> <b>Razina zvučne snage:</b>	<b>103 dB (A)</b>

NIVEAU SONORE D'EMISSION:

A VIDE

Pression acoustique LpA poste opérateur  
Incertitude

92 dB  
3

Puissance acoustique LWA  
Incertitude

103 dB  
3

Valeurs déterminées suivant le code d'essai de l'annexe B de la norme EN 61029-1 avec emploi des normes de base ISO 11201 et ISO 3744.

Les niveaux de pression acoustique obtenus in situ dépendent:

- Des niveaux réels de la machine considérées, en prenant en compte les incertitudes déclarées;
- Du local et de l'installation de la machine. Préférez une pièce dont l'acoustique est plus feutrée. Evitez les pièces vide à grande résonance. Placez vous auprès d'une fenêtre le cas échéant.
- Des outils montés, des pièces travaillées, des réglages choisis,...

 <b>L<sub>15,9</sub></b>	Niveau de vibration : Hand/arm vibration level : Vibrationspegel Hand/Arm : Nivel de vibración mano/brazo : Livello di vibrazione mano/braccio : Nivel de vibração mão/braço : Trillingsniveau hand/arm : Στάθμη κρα'οασημών : <b>Poziom wibracji rżka/ramiż :</b> Tärinätaso: Vibrationsnivå hand/arm : Vibrationsniveau : Nivel vibrații :	<b>Уровень вибрации :</b> Titreşim seviyesi : Úroveň vibrací : <b>Hladina vibrácií :</b> ממת תנודות مستوى الارتجاج ج. Vibrációs szint : <b>Nivo vibracij :</b> <b>Равнище :</b> <b>Vibrācijas līmenis.</b> <b>Vibracijos lygis</b> <b>Vibratsiooni nivo</b> Razina vibracije:	<b>15,9 m / s2</b>

VIBRATIONS:

Total des valeurs de vibration ( somme vectorielle des trois directions ) déterminée selon EN 60745:

a 15,9 m/s<sup>2</sup>  
Incertitude K<sub>w</sub> 1,5 m/s<sup>2</sup>

L'amplitude d'oscillation peut être utilisée comme valeur de comparaison d'outils électroportatifs.

Attention: Si l'outil électroportatif est utilisé pour d'autres applications, avec d'autres outils de travail, l'amplitude d'oscillation peut être différente.

	<p>Recyclable, soumis au tri sélectif          Recyclable, subject to recycling          Recyclingfähige, unterliegen Recycling          Reciclables, sujetos a reciclaje          Riciclabili, soggettii a riciclaggio          Recicláveis, sujeitos à reciclagem          Recycleerbare, onderworpen aan recycling          Ανακυκλώσιμες συσκευασίες που υπόκεινται σε κύκλωση          Opakowanie nadaje się do recyklingu podlegają recyklingu          Kierrätettävien pakkausten kohteena kierrätys          Återvinningsbara förpackningar omfattas återvinning  <b>Рециклиращи се опаковки подлежат на рециклиране</b>          Genanvendelig underlagt genbrug</p>	<p>Reciclabile sub rezerva reciclare  <b>Повторно упаковка подлежит вторичной переработке</b>          Geri dönüştürme Geri dönüştürülebilir ambalaj konusu          Recyklovateľné podliehajúce recyklácii          Recyklovateľné podliehajúce recyklácii          וחומר החיראה אשון          ریوندتل ها عال یضرت ریوندتل ها عال قلابازا فجل یئلوا قوب یئلوا          Újrahasznosítható csomagolás alá újrahasznosítás          Recikliranti predmet recikliranje          Pakendite suhtes ringlussevõtu          Pärsträdajams iepakojums otrreizējai pārstrādei          Perdirbamų taikomos perdirbimo  <b>Može se reciklirati, podložno selektivnom sortiranju</b></p>	<b>X</b>
---	---	---	----------

	<p>Soumis à recyclage          Subjected to recycling          Sujeto a reciclaje          Sottoposti a riciclaggio          Sujeitos à reciclagem          Não deite no lixo :          Niet wegwerpen :          Μην την πετάτε :          Nie wyrzucac :          Älä heitä pois luontoon :          Batteriet får inte kastas :          Bortkast det ikke :          Nu le auncati :</p>	<p>Не выбрасывайте в мусорный ящик          Atmayıniz :          Nevyhazujte je do bežného odpadu :          Neodhadzovat :          אין לזרוק סוללות          فلا ترمدها ملذا في القمامة.          ne mečite1          Ne odvržite ga/jih vstran :          Не го изхвърляйте :          Ärge visake seda minema :          Nemétykite :          Nemest :          Podvrqnuo recikliranju</p>	<b>X</b>
---	---	---	----------

**FR-Recyclage des déchets :**

Les outils, accessoires et leur emballages doivent suivre une voie de recyclage adaptée. Conformément aux directives Européenne 2012/19/UE et 2006/66/CE, les composants d'un produit doivent être séparés, collectés, recyclés ou éliminés en conformité avec les réglementations environnementales en vigueur. Les appareils, batteries, piles, huiles, emballages devront être déposés dans les systèmes d'élimination des déchets spéciaux tels que déchetteries. Renseignez-vous auprès de votre commune pour connaître l'organisme le plus proche à même de retraiter ou de collecter ces déchets.

**EN-Waste recycling:**

The tools, accessories and their packaging must use an appropriate recycling channel. In compliance with European Directives 2012/19/UE and 2006/66/CE, a product's components must be separated, collected, recycled or eliminated in accordance with the environmental regulations in force. The appliance, batteries, oils and packaging must be deposited in the special waste elimination systems such as the waste collection centres. Ask your commune for information on the nearest organisation in a position to reprocess or collect this waste

 <p>Li-ion</p>	<p>Recyclage des batteries :          Recycling the batteries :          Recycling von Batterien:          Reciclaje de baterías:          Riciclaggio delle batterie:          Reciclagem de baterias:          Batterijen recycelen:          Ανακύκλωση μπαταριών:          Recykling baterii:          Akkujen kierrätys:          Återvinning av batterier:          Рециклиране на батерии:          Genbrug af batterier:</p>	<p>Reciclarea bateriilor:          Утилизация аккумуляторов:          Geri dönüştürme piller:          Recyklační baterie:          Recyklačné batérie:          תוללוס החימי:          لريوندتل قدا عال تايراطي          Újrahasznosító elemek:          Recikliranje baterij:          Patareide ringlussevõtt:          Bateriju pārstrāde:          Perdirbančios baterijos:          Recikliranje baterija:</p>	<b>X</b>
---	--	--	----------

**FR- Recyclage des batteries:**

À la FIN de leur vie utile, S'éparez vous de vos batteries avec précautions pour notre environnement. La batterie contient du matériel dangereux pour vous et pour l'environnement. Il doit être retiré et éliminé séparément dans une installation qui accepte des batteries au lithium-ion.

**EN-Recycling of batteries:**

At the end of their useful life, discard batteries with due care for our environment. The battery contains material which is hazardous to you and the environment. It must be removed and disposed of separately at a facility that accepts lithium-ion batteries.

# XF-Wrench

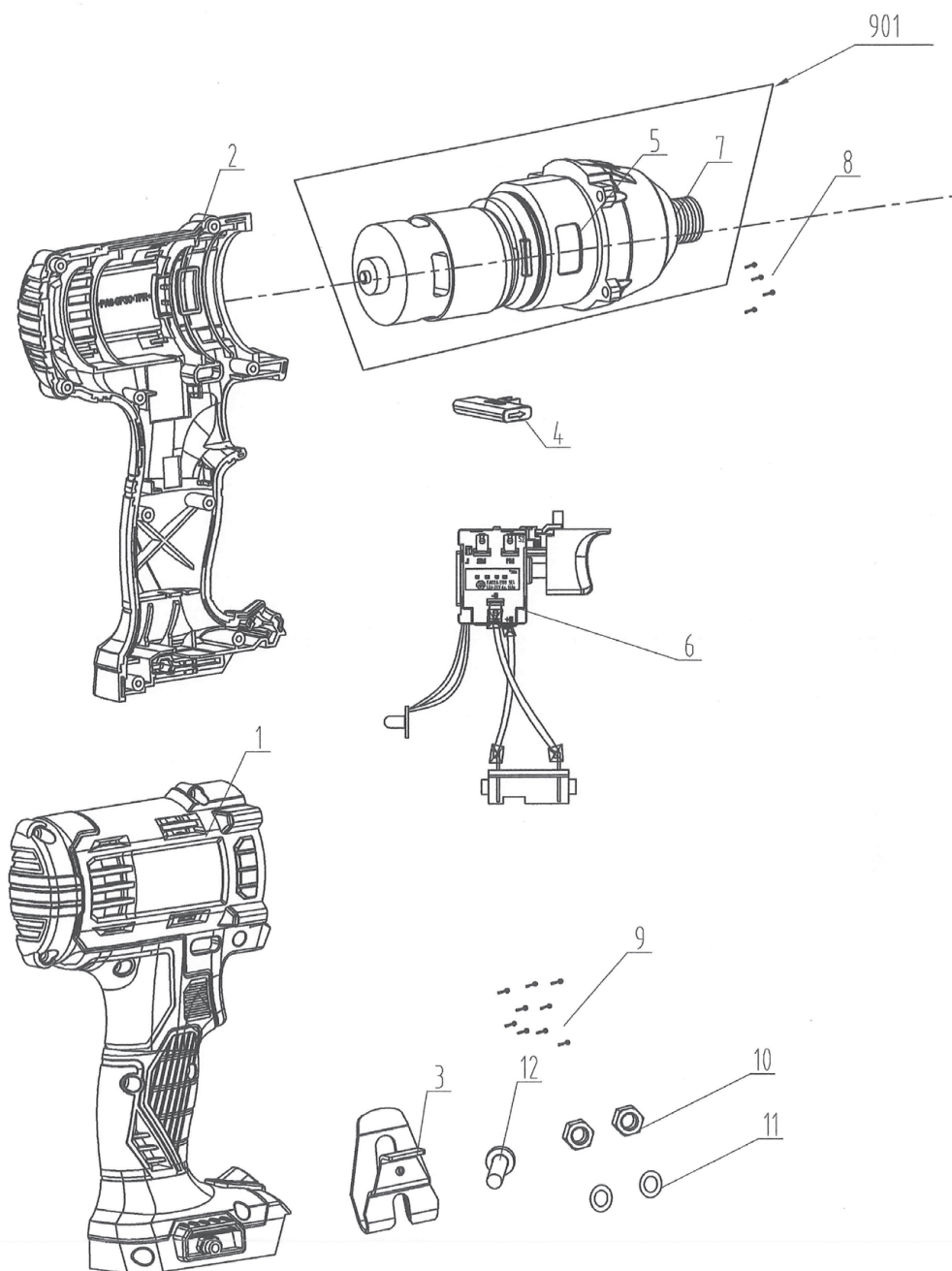

DECLARATION DE CONFORMITE  
VERKLARING VAN OVEREENSTEMMING  
DECLARACION DE CONFORMIDAD  
DICHIARAZIONE DI CONFORMITA  
KONFORMITÄSERKLÄRUNG  
DECLARATION OF CONFORMITY  
DECLARAÇÃO DE CONFORMIDADE  
DEKLARACJA ZGODNOSCI Z NORMAMI  
OM ÖVERENSSTÄMMELSE  
VAATIMUSTENMUKAISUUSVAKUUTUS  
OVERENSSTEMMELSESERKLÆRING  
Δήλωση συμμόρφωσης/συμμόρφωσης

DECLARAȚIE DE CONFORMITATE  
VYHLÁSENIE ZHODY  
Декларация соответствия  
תצהיר תואמת  
Uygunluk beyanı  
التصريح بالخطابفة  
PROHLÁŠENÍ SHODY  
EGYZEZŐSÉGI NYILATKOZAT  
Декларация за съответствие с нормите  
IZJAVA O SKLADNOSTI  
DEKLARACIJA  
ΑΤΤΙΚΤΗΣ ΔΕΚΛΑΡΑCΙΑ  
KINNTUS  
IZJAVA O SKLADNOSTI

**Le soussigné,**  
Ondergetekende,  
Der Unterzeichner,  
O abaixo assinado,  
Undertecknad,  
Долуподписаният  
Undertegnede  
Subsemnatul,  
Я, нижеподписавшийся,  
Imzalayan,  
Niže podpešany,  
Toliau pasirašęs

**Déclare par la présente que,**  
Verklaart hiermede dat,  
Erklårt hiermit daß,  
Declara pela presente que,  
Förklarar härmed att  
Заявлява с настоящото  
erklærer hermed, at  
Declar prin prezenta că,  
настоящим подтверждаю, что  
Mevcut belgeyle beyan ediliyor ki,  
tinto prohláše, že,  
Pareiškia, kad,

Personne autorisée à constituer  
le dossier technique :  
Christophe HUREL



FAR GROUP EUROPE  
192, Avenue Yves Farge  
37700 St. Pierre-des-Corps  
FRANCE

El suscrito,  
Il sottoscritto,  
The undersigned,  
Nijęz podpisany  
Allekirjoittanut,  
Ουπτογεγραμμένος  
Nižšie podpisany  
החתום מטעם  
الذوقع أدناه  
Alulírott,  
Podpisani,  
Apakšā parakstījies  
allakirjutanu  
Doļje potpisani,

Declara por la presente, que,  
Dichiare che,  
Declares that,  
Oöwiadoza niniejszym, że  
Ilmoittetaan täten että,  
Δηλώνω με την Παράστα  
týmto vyhlasuje, že  
מצהיר בזה כי  
يصرح استنادا على ذلك  
kijelentem, hogy a készülék Izjavlja da,  
Pareiškia, kad,  
Ar šo apliecinā, ka,  
Kinnitab, et  
Izjavljuje u ovom dokumentu da je

Cordless drill / Perceuse visseuse déviseuse sans fil / Schnurlose Bohrmaschine / Taladradora inalámbrica / Trapano senza fili /  
Furadora sem fio / Draadloze boormachine/ Ασύρματ κρουστικ δρπάντ - ιδγ Wiertarka przenośna / Johdoton porakone / Sladdlös bormmaskin /  
Ударнопробивна машина / Trádlös boremaskine/skruetrækker / Mašiná electricá fárá fir de găurit și însurubat /дешурбат/ Беспроводной гаиковерт /  
Vidali vidasz kablósuz matkap / Vrtačka uzavíračka otevíračka bezdrátová / Bezdrátová skrutkovacia-odskrutkovacia vrtačka / פיתחת ורג א לחוטי /  
מודדחל הברגרה / Önmetsző csavarbehajító fűrógép / Akumulatorski vrtalnik vijačnik /  
Juhtmeta drell / Bevielés prískamos ir atskamos grężimo staklės / Urbis saskrūvēšanai un atskrūvēšanai bez vada / Bežična akumulatorski odvijač

code

FARTOOLS / 216036 / XF-Wrench / PLIL-613

**Est conforme et satisfait aux directives et normes CE,**  
In overeenstemming is met en Voldoet aan EG richtlijnen,  
Den folgenden EU-Bestimmungen entspricht,  
Respeita e está em conformidade com as normas CE,  
Överensstämmer med och uppfyller EG-standarder,  
Съответства и отговаря европейските норми  
Er i overensstemmelse med og overholder EU standarderne  
Este conform și satisface normele CE  
полностью соответствует и удовлетворяет  
требованиям стандартов EC  
CE şartlara uygundur,  
odpovídá normám ES.  
Atitinka ir atitinka EB direktyvas ir standartus,

Cumple con la directivas de la CE,  
E conforme alle direttive CEE,  
Complies with the EEC directives and standards,  
Odpowiada normom UE,  
Täyttää EU-vaatimukset,  
Είναι συμμόρφω και ανταποκρίνεται στα Πρότυπα CE  
zodpovedá normám ES.  
מתאים ועונה לתקני CE  
بان الرجهاز خطابفة و تجايي معايير مجموعة الدول الأوروبية  
kielégíti a CE szabványok előírásait.  
Je v skladu z in izpolnjuje norme Evropske skupnosti.  
Atbilst un atbilst EK direktīvas un standartos,  
Vastab ja vastab EU direktīvidele ja standartitele,  
Sukladan i ispunjava direktive i standarde CE,

2014/30/EU 2006/42/EC 2011/65/EU&2015/863/EU

EN 62841-1:2015  
EN 62841-2-2:2014  
EN 55014-2:2015  
EN 55014-1:2017

Christophe HUREL,  
Président Directeur Général  
13/08/2020  
Fait à St. Pierre-des-Corps





## GARANTIE - WARRANTY



### FR. GARANTIE

Cet outil est garanti contractuellement contre tout vice de construction et de matière, à compter de la date de vente à l'utilisateur et sur simple présentation du ticket de caisse. La garantie consiste à remplacer les parties défectueuses. Cette garantie n'est pas applicable en cas d'exploitation non conforme aux normes de l'appareil, ni en cas de dommages causés par des interventions non autorisées ou par négligence de la part de l'acheteur. La garantie ne s'applique pas sur les dommages causés par une défaillance de l'outil.

### DE. GARANTIE

Die Garantiezeit für dieses Gerät in bezug auf Konstruktions- und Materialfehler beträgt lt. Vertrag bei Vorlage des Kassensbons. Die Garantieleistung besteht im Ersatz schadhafter Teile. Die Garantie erlischt bei einem Einsatz des Geräts, der nicht normentsprechend ist, bei Schäden, die auf unsachgemäße Eingriffe zurückzuführen sind bzw. bei Nachlässigkeit seitens des Käufers. Die Garantie erstreckt sich nicht auf Schäden, die auf Fehlfunktionen des Geräts zurückzuführen sind.

### IT. GARANZIA

Quest' attrezzo è garantito per contratto contro qualsiasi difetto di costruzione e di materia, a partire dalla data di vendita all' utente e su semplice presentazione dello scontrino. La garanzia consiste nel sostituire le parti difettose. Questa garanzia non è applicabile in caso di sfruttamento non conforme alle norme dell' apparecchio, né in caso di danni causati da interventi non autorizzati o da negligenza da parte dell' acquirente. La garanzia non si applica ai danni causati da un' avaria dell' attrezzo.

### EN. GARANTEE

This tool is guaranteed, in writing, against any defect in manufacture or parts from the date of sale, upon simple presentation of the sales slip. The guarantee is limited to the replacement of faulty parts. This guarantee is not applicable in the event of usage which is not conform with the intended usage of the apparatus, nor in the event of damage caused by unauthorised servicing or negligence on behalf of the purchaser. This guarantee does not apply to any damage caused by the failure of this tool.

### ES. GARANTIA

Esta herramienta se garantiza contractualmente contra todo defecto de construcción y materia, a partir de la fecha de venta a l' usuario y sobre simple presentación del recibo de caja. La garantía

consiste en sustituir a las partes defectuosas. Esta garantía no es aplicable en caso de explotación no conforme a las normas del aparato, ni en caso de daños causados por intervenciones no autorizadas o por negligencia por parte del comprador. La garantía no se aplica sobre los daños causados por un fallo del herramienta.

### NL. GARANTIE

Dit gereedschap heeft een garantie tegen constructiefouten en materiaaldefecten, die geldig is vanaf de aankoopdatum door de gebruiker, op vertoning van de kassabon. De garantie betreft de vervanging van de defecte onderdelen. Deze garantie is niet van toepassing indien het apparaat niet volgens de normen gebruikt is, noch in geval van schade veroorzaakt door oneigenlijk gebruik of nalatigheid van de koper. De garantie is niet van toepassing op schade voortvloeiend uit een defect van het gereedschap.

### PT. GARANTIA

Esta ferramenta tem uma garantia contratual contra qualquer defeito de construção e de material, a partir da data de venda ao utilizador e sobre simples apresentação do talão da caixa. A garantia consiste em substituir as partes defeituosas. Esta garantia não é aplicável no caso de exploração não conforme às normas do aparelho, nem em caso de danos causados pelas intervenções não autorizadas ou por negligência da parte do comprador. A garantia não se aplica para os danos causados por uma falha da ferramenta.

### EL. Εγγύηση

Το εργαλείο αυτό φέρει συμβατική εγγύηση για οποιούδήποτε ελαττωμα κατασκευής από την ημερομηνία Πώλησης στο χροστή, με ΑΠΛ. ή Προκαταβ. ή εγγύηση αΠΟΤΕΛΕΙται από την αντικατάσταση των ελαττωματικών τμημάτων. Η Παρούσα εγγύηση δεν εφαρμόζεται σε Περύπτωση χροστής μη συμφωνής με τα Προστίθ. της συσκευής, η σε Περύπτωση ζημιάς που Προκλήθηκε από μη εγκριμένη επεμβάση ή από αμέλεια του αγοραστή. Η εγγύηση δεν εφαρμόζεται στις ζημίες που Προκαλούνται από βλάβη του εργαλείου Στάθρο ή κενό υ Διαστήμο - Παρ Εμβύσμα

### PL. GWARANCJA

Narz'dzie jest obje'te gwarancją na wszelkie wady konstrukcyjne i materiałowe, licząc, od daty sprzedaży u'ytkownikowi i po okazaniu paragonu kasowego. Gwarancja obejmuje wymianę cz. Acj wybrakowanych. Gwarancja nie, znajduję zastosowania w przypadku u'ytkowania niezgodnego z normami urz'adzenia, ani w przypadku szkód spowodowanych działaniami

niedozwolonymi lub zaniedbaniami ze strony nabywcy. Gwarancja nie obejmuje szkód powstałych z powodu upadku urz'adzenia.

### SV. GARANTI

Detta verktyg har en avtalsenlig garanti mot konstruktions och materialfel, från och med tidpunkten för användarens inköp och genom uppvisning av kassavittot. Garantin består i att ersätta de bristfälliga delarna. Denna garanti gäller inte om användningen inte motsvarar apparatens standarder, inte heller vid skador som orsakas av ej tillåtna ingrepp eller på grund av köparens vårdslöshet. Garantin gäller inte förskador som orsakats av att verktyget fungerat bristfälligt.

### FI. TAKUU

Tämän laitteen takuu on voimassa sopimuskennukaisesti kattaa kaikki rakenne- ja materiaaliu'vialt lukien ostopäivästä kassakuitista vastaan. Takuu sisältää viallisten osien korvaamisen. Takuu ei korvaa ohjeidenvastaista käyttöä eikä vaiuuttamattomien henkilöiden käsittelystä tai ostajan huolimattomuudesta aiheutuneita vahinkoja. Takuu ei vastaa myöskään toimintahäiriöistä aiheutuneita vahinkoja.

### BU. Гаранция

Този инструмент е под договорна гаранция срещу всякакъв дефект в изработката и използваните материали, считано от датата на продажба на потребителя и само срещу представяне на касовата бележка. Гаранционното обслужване се състои в замяна на дефектните части. Настоящата гаранция не е валидна когато апаратът се използва по начин, несъответстващ на стандарта за работа с него, както и в случай на щети, нанесени от неоторизирани лица, или вследствие на проявена небрежност от страна на потребителя. Гаранцията не покрива щети, произтекли вследствие на техническа неизправност на апарата.

### DA. GARANTI

De'tte værktøj er dækket af en garantikontrakt for konstruktions- og materialefejl, som gælder fra købsdatoen ved visning af kassebonen. Garantien består i at u'dskifte de defekte dele. Garantien dækker ikke fejl opstået som følge af anvendelse, som ikke overholder standarderne for apparatet, eller skader opstået ved ikke autoriserede indgreb eller sløshed fra brugerens side. Garantien dækker ikke skader opstået, fordi værktøjet har svigtet.

## SERVICE APRÈS VENTE - AFTER SALE SERVICE

FARGROUP EUROPE - 192, Avenue Yves Farge - 37700 St. Pierre-des-Corps - FRANCE

fargroup@fargroup.net



**RO. GARANTIE**

Acest aparat este garantat din punct de vedere contractual împotriva tuturor viciilor de construcție și de material, începând de la data vânzării lui către utilizator și la simpla prezentare a bonului de casă. Garanția constă în înlocuirea componentelor defecte. Această garanție nu se aplică în cazul exploatarei în alt mod decât cel recomandat de normele aparatului și nici în caz de stricăciuni provocate de intervenții neautorizate sau prin neglijența cumpărătorului. Garanția nu se aplică asupra pagbelor cauzate de o defectare a aparatului.

**RU. ГАРАНТИЯ**

Данное изделие обладает имеющей силу контракта гарантией, покрывающей все возможные дефекты изготовления и материала. Гарантия вступает в силу с даты продажи изделия пользователю, для этого достаточно сохранить и предъявить полученный в кассе чек. Гарантия обязывает изготовителя заменить дефектные части изделия. В случае не соответствующего нормам использования изделия, не санкционированного демонтажа или ремонта или небрежного обращения с изделием, действия гарантии прекращаются. Гарантия не покрывает ущерба, возникшего в результате соев в работе изделия.

**TU. GARANTI**

Bu araç, satış tarihinden itibaren, kullanicının sadece vezne alıncısını sunmasıyla tüm üretim ve malzeme hatasına karşı garantilidir. Garanti eksik olan kısımları değiştirilmek içindir. Bu garanti aracın şartlarına uygun olmayan işleme durumunda, izin verilmeden kullanımlardan kaynaklanan hasarlarda veya alıcının isteği durumunda uygulanmaz. Garanti malzemenin bir eksikliğinden meydana gelen bir zararda uygulanmaz.

**CS. ZÁRUKA**

Pro tento nástroj platí smluvní záruka na všechny výrobní a materiálové vady od data prodeje uživateli a na základě předložení pokladního bloku. Záruka spočívá ve výměně vadných částí. Tato záruka neplatí v případě použití přístroje, které neodpovídá normám, ani v případě škod způsobených nepovolenými zásahy nebo nedbalostí ze strany kupujícího. Záruka se nevztahuje na škody způsobené závadou nástroje.

**SK. ZÁRUKA**

Pre tento nástroj platí zmluvná záruka na všetky výrobné a materiálové chyby od dátumu predaja užívateľovi a na základe predloženia pokladničného

bloku. Záruka spočíva vo výmene chybných častí. Táto záruka neplatí v prípade použitia prístroja, ktoré nezodpovedá normám, ani v prípade škôd spôsobených nepovolenými zásahmi alebo nedbalosťou zo strany kupujúceho. Záruka sa nevzťahuje na škody spôsobené poruchou nástroja

**HE. אחריות**

חשבונית קופה. האחריות-משמעה מיום המכירה למשתמש עם הצגת מפני כל ליקוי בייצור או בחומרי החל הי עככלי זה חלה אחריות לפי חוקה נקד שנגרם על ידי התערובות תללח שאינו מתאים לתקינים ובמקרה של אינה חלה במקרה של שימוש במכשיר החלפה תחלקם הלקיים אחריות זו חלה על נזק שנגרם על ידי תקלה בכלי. רשלנות מאת הקונה. האחריות אינה מוכח או על ידי

**AR. الضمان**

على مورد توريد توريد ببطاقة الشراء يتغل في تاريخ البيع الى المستعمل وينهاء في التصدي عوفى الجواهر. إعتباراً من الع دة مضمونه تغاردي من أي عيب في حالة تعرضه لآل لفات إن منه غير المطابق لمعايير الجاهز. ولا قابلاً للتطبيق في حالة الاستخدام الآلة العاطلة لا يكون هذا الضمان الإنتاج عن خلل الضمان فإي استبدال المشتري لا يطبق الضمان على الصنوبر غير مخصصة أو في حالة الأعمال عن قبل زاتجة عن عمليات تدل

**HU. GARANCIA**

Erre a szerszámra szerződéses garanciát vállalunk bármilyen gyártási és anyaghiba felmerülése esetére, a fogyszót részére történt eladás napjától számítva, a pentztári blokk egyszerű felmutatása ellenében. A garancia a hibás alkatrészek cseréjére terjed ki. Ez a garancia nem érvényes, ha a készüléket nem rendeltetésszerűen használták, sem illetéktelen beavatkozások, vagy a vásárló hanyagsága okozta károk esetén. A garancia nem fedezi azokat a károkat, melyeket a szerszám hibás működése okozott.

**SL. GARANCIJA**

To orodje je z garancijsko pogodbo zaščiteno proti vsem napakam v izdelavi in v sestavnem materialu od datuma prodaje naprej in ta velja ob predložitvi blagajniškega računa. Garancija velja za zamenjavno delov z napako. Ta garancija ne velja za uporabo orodja, ki ni v skladu z normami, predpisanimi za omenjeno orodje in za primere okvar, ki nastanejo zaradi nedovoljenih posegov na orodju ali zaradi malomarnega rokovanja kupca. Garancija ne velja za škodo, ki jo lahko povzroči okvara orodja.

**ET. GARANTII**

See tööriist kuulub lepingu järgi garantiiremonti arvestades alates müümise päevast ja kasutajate alusel kasutatava kõigi konstruktsiooni- ja materjalivigade puhul. Garantii seisneb defektsete osade väljavahetamises. See garantii ei kehti aparadi normide ebatavalise eiramise puhul ega ostja poolt keelatud viisil kasutamisest või hooletusjätmisest

tulenevate kahjude korral. Garantii ei kehti seadme defektidest põhjustatud kahjude puhul

**LV. GARANTIJA**

Šis prietaisys yra užtikrinamas kaip itin geros kokybės, nuo jo pardavimo datos iki jo panaudojimo, ir jam yra suteikiama šios garantinis talonas. Garantijos metu galima pakeisti atsitadusius trumplaikius gėdimus. Ši garantija netaikoma esant nėtikamam naudojimui ar nesilaikant reikiam šio aparato vartojimo instrukcijų, tai pat pačiam perkėjui jį sugadinus. Garantija taip pat netaikoma, prietaisų naudojant ne pagal paskirtį ir jį apgadinus

**LT. GARANTIJA**

Šim darbarikam ir ligumė noteikta garantija visiem defektiem, kas saistās ar konstrukciju un materiālu, sākot ar pārdošanas datumu, kad mašinu pārdod lietotājam un vienkāši uzrādōt kases čeku. Garantija iekļauj bojāoto daļu nomaiņu. Ši garantija nav derīga, ja aparātš nav lietots saskaņā ar drošības noteikumiem, ne gadījumos, ja bojājumi radušies nesankcionētas iekāušības gadījumā vai arī pēreja nolaidības dēļ. Garantija nav derīga, ja bojājumi radušies darbarika defekta dēļ

**HR. JAMSTVO**

Ovaj alat ima ugovorno jamstvo u slučaju bilo kakvih nedostataka u konstrukciji i materijalu, od datuma prodaje korisniku uz jednostavno predocenje računa. Jamstvo se sastoji u zamjeni neispravnih dijelova. Ovo se jamstvo ne primjenjuje u slučaju uporabe i eksploatacije koja nije sukladna standardima uređaja, niti u slučaju štete uzrokovane neovlaštenim intervencijama ili nemarom kupca. Jamstvo se ne primjenjuje na štetu uzrokovanu nekim nedostatkom alata.

**SERVICE APRÈS VENTE - AFTER SALE SERVICE**

FARGROUP EUROPE - 192, Avenue Yves Farge - 37700 St. Pierre-des-Corps - FRANCE

fargroup@fargroup.net

## FAR GROUP EUROPE

Une société du groupe **SIGMA**

192, Avenue Yves Farge  
37700 St. Pierre-des-Corps  
FRANCE

[www.fartools.com](http://www.fartools.com)

