

TB3KR

KammRack

Instructions

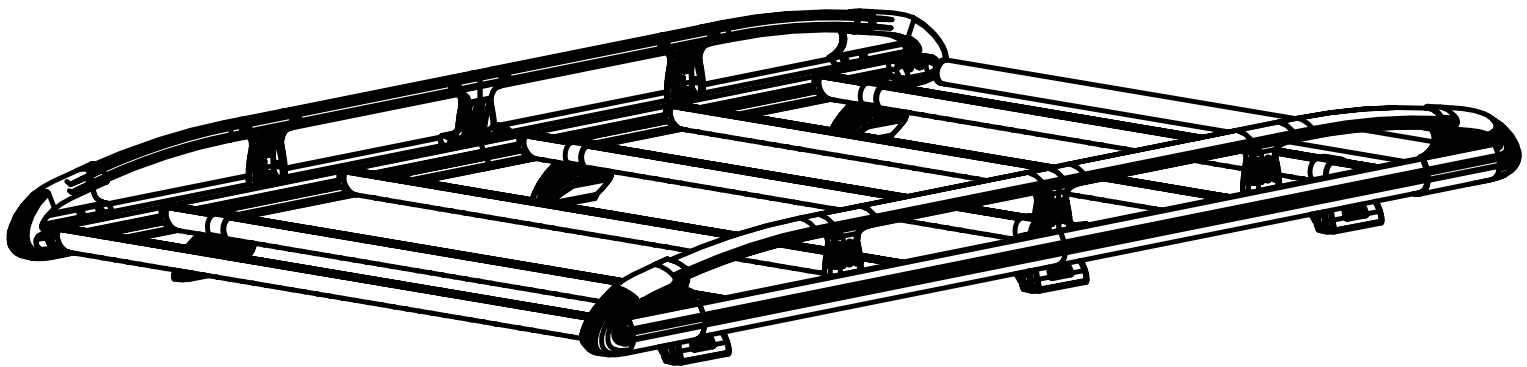

CITY CRASH (✓)
According to ISO/ PAS 11154:2006

TB3KR:

Ford Transit Custom, 2012-

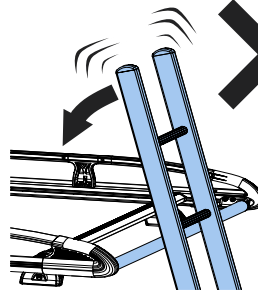
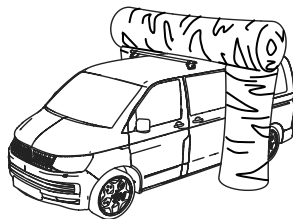
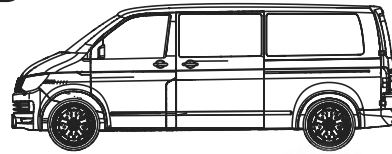

Max
50kg/110lbs

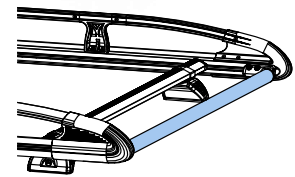

KammRack

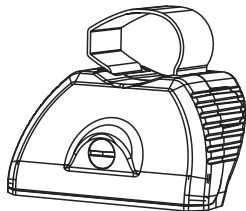

SA397U x 3

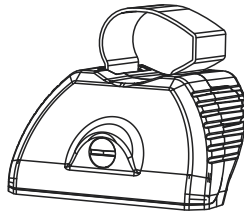

SA398U x 3

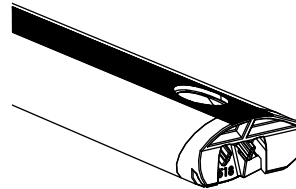

**SA429/
SA467**



C04 x 6
optional upgrade

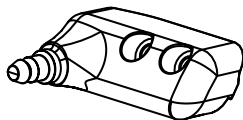

PS519 x 1

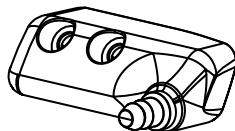

PS520 x 1

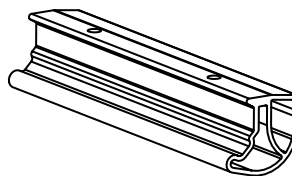

EXT15-02

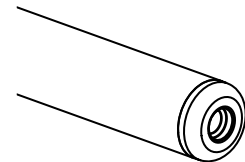

SA437 x 1

LHS x 2

RHS x 2

Centre x 2

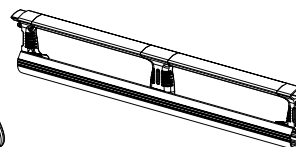
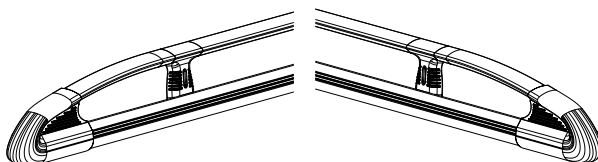

ASF x 1

Fitting Kit

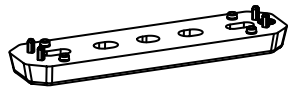

PS178 x 4

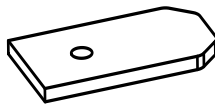

**PS615
(8mm)
x 8**

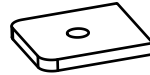

PS492 x 6

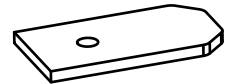

**PS491
(3mm)
x 6**

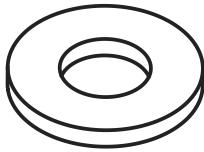

FW002 (M8) x 12

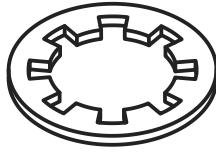

FW009 (M8) x 12

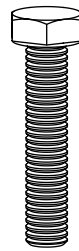

**FS061
(M8 x 35) x 8**

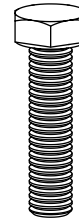

**FS062
(M8 x 25) x 4**

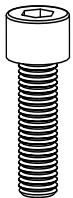

**FS059
(M8 x 25) x 18**

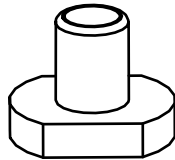

FN085 x 18



FT05 x 1



FT01 x 1



1.

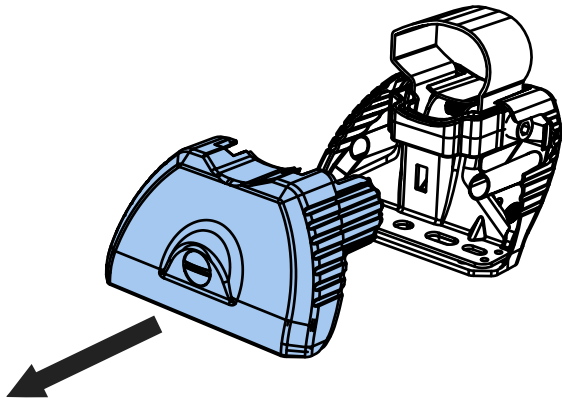

2.

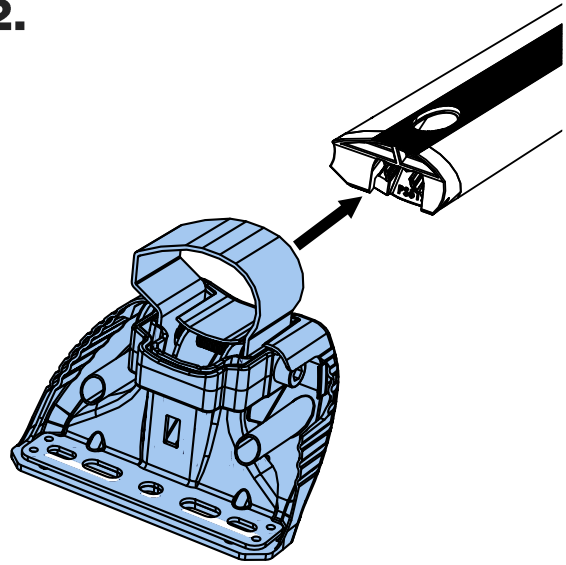

3

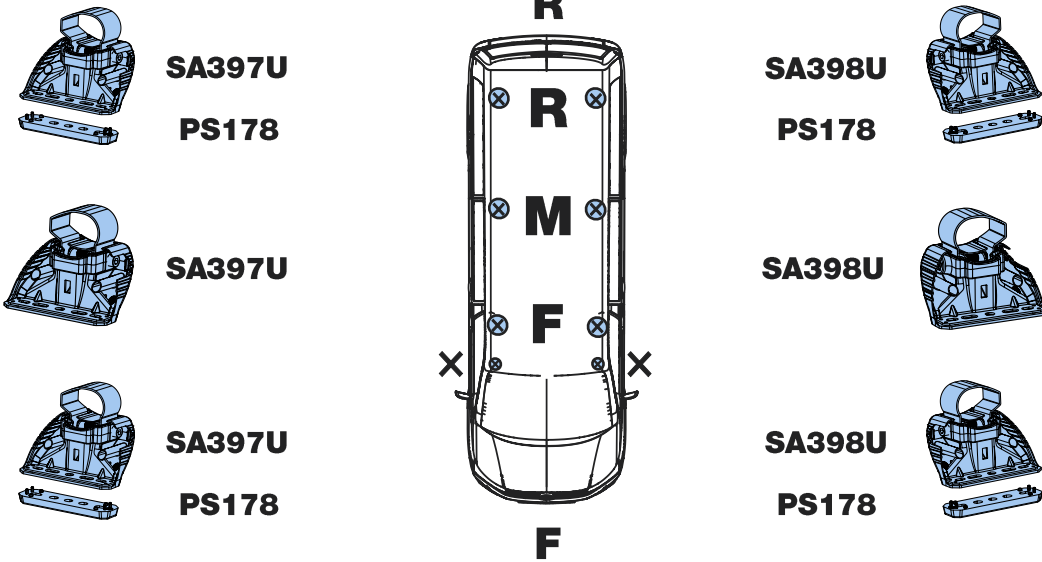

4a.

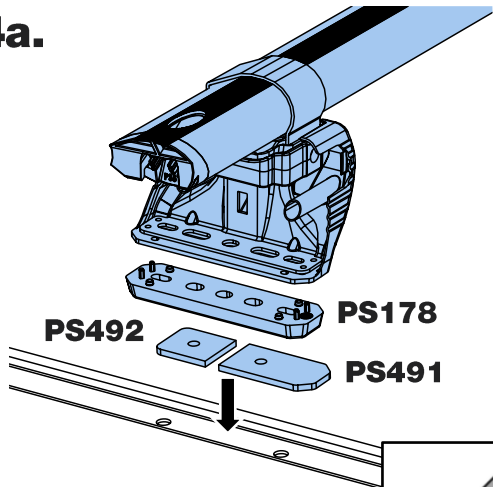

! FORD TRANSIT
CUSTOM 2012-2023

R



4b.

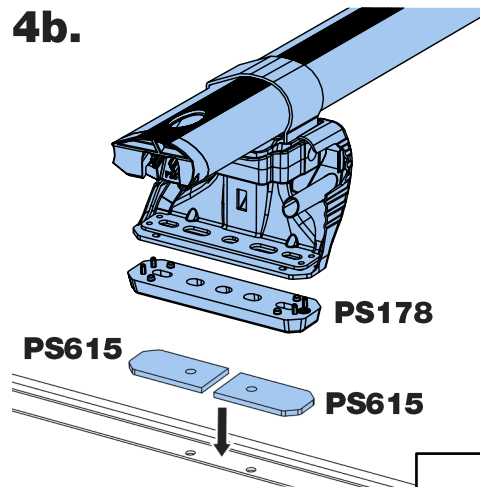

! FORD TRANSIT
CUSTOM 2023-

R

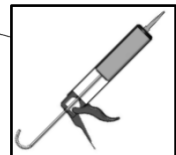

5a.

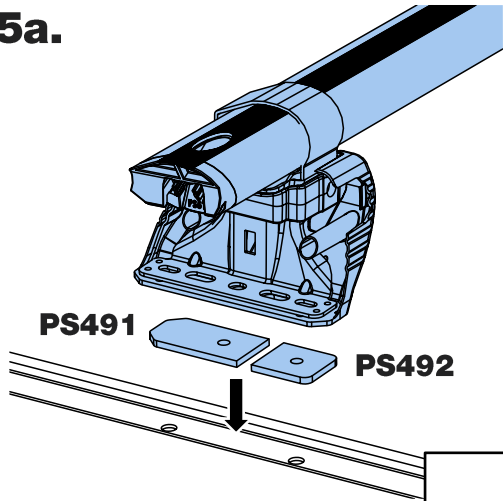

! FORD TRANSIT
CUSTOM 2012-2023

M

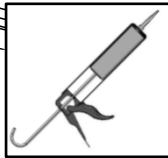

5b.

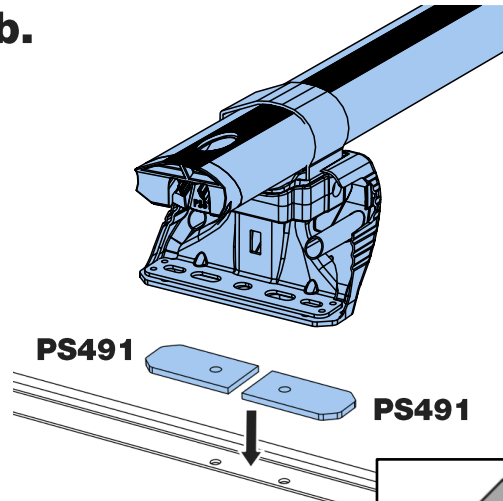

! FORD TRANSIT
CUSTOM 2023-

M

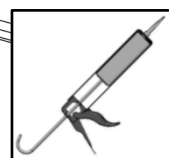

6a.

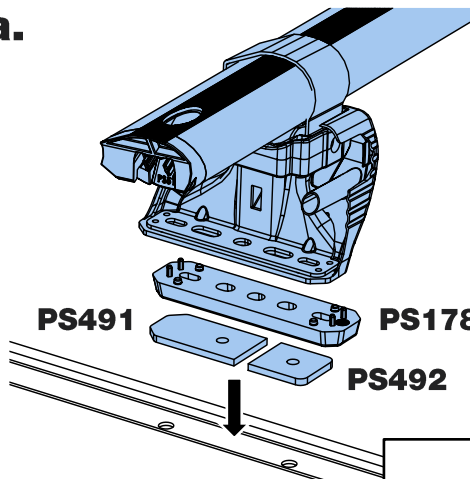

! FORD TRANSIT
CUSTOM 2012-2023

F

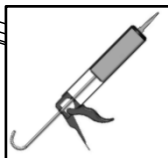

6b.

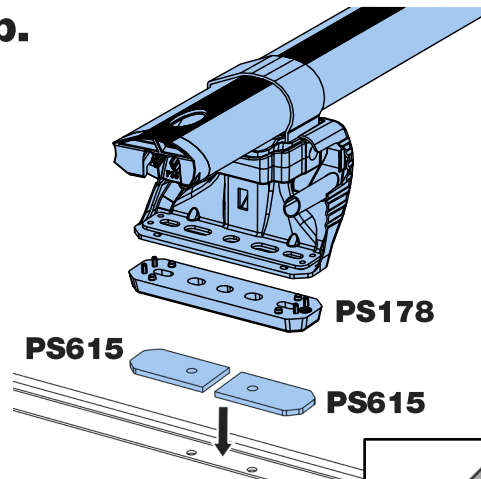

! FORD TRANSIT
CUSTOM 2023-

F

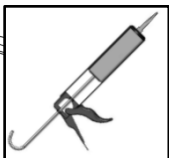

7.

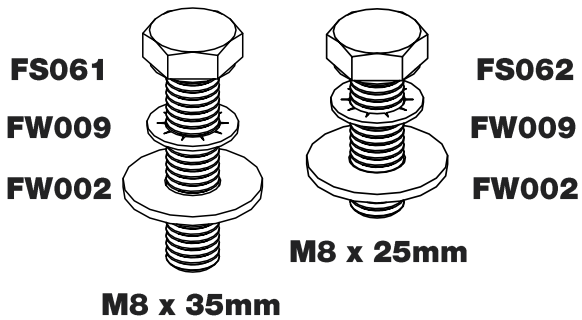

M8 x 35mm

M8 x 25mm

8.

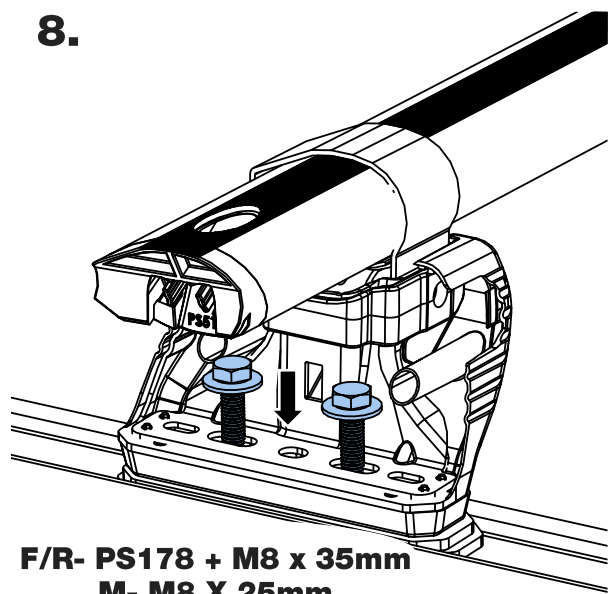

F/R- PS178 + M8 x 35mm
M- M8 X 25mm

9.

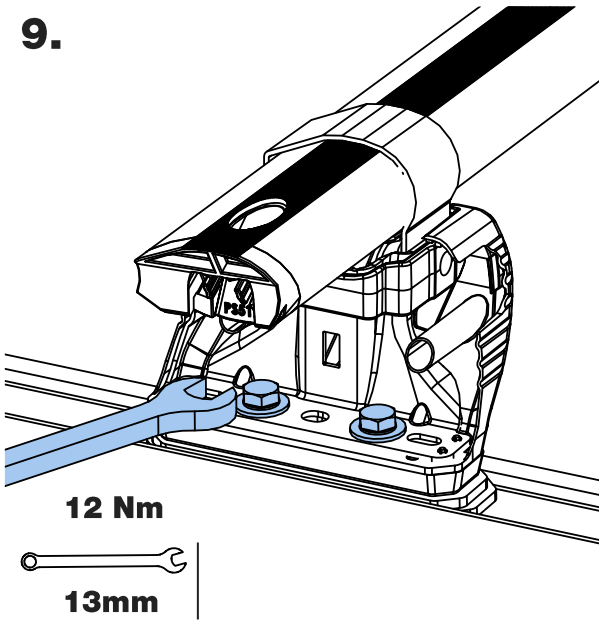

10.

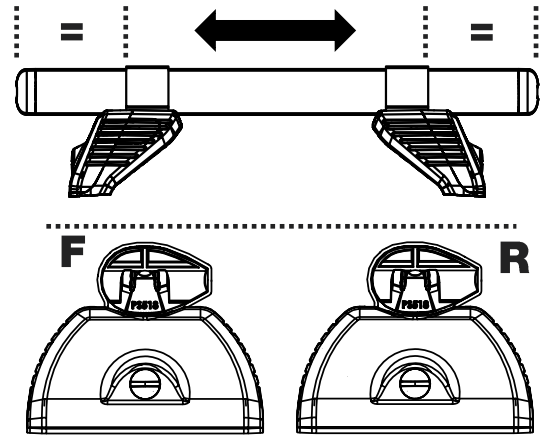

11.

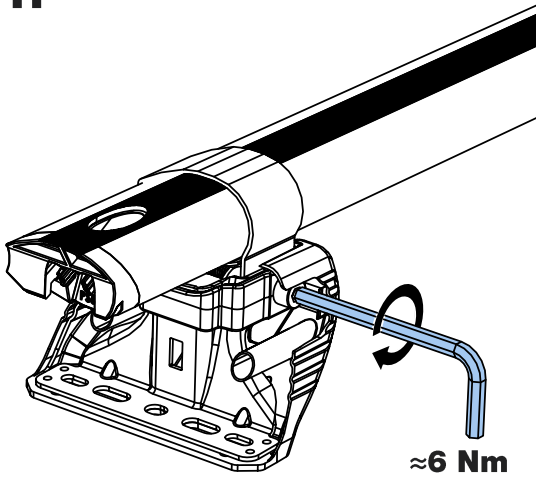

12.

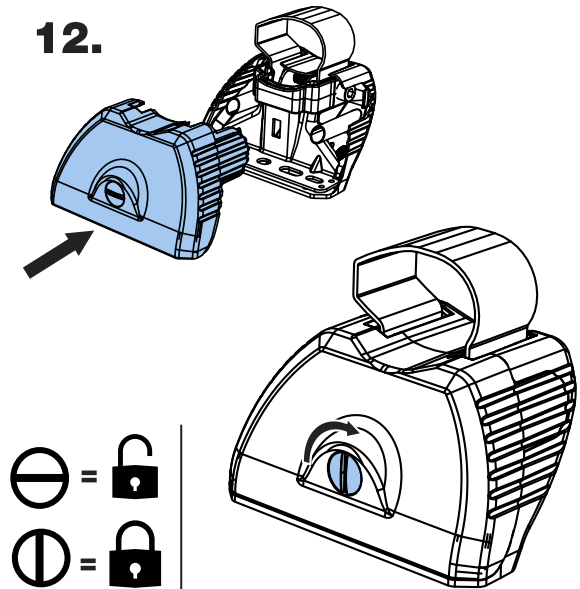

13.

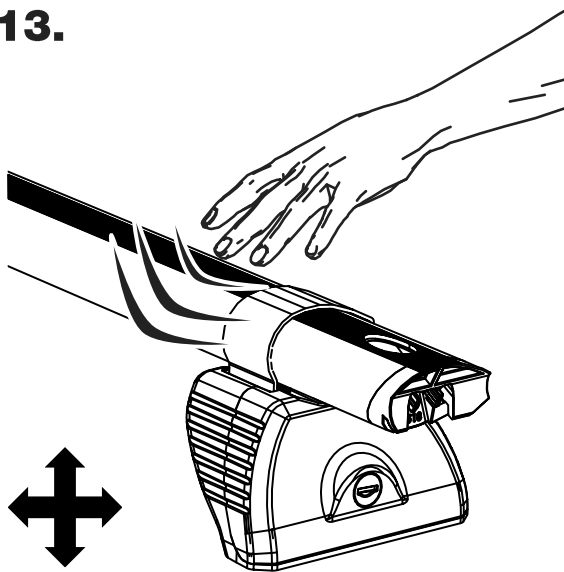

K615/B615- Ford Transit Custom 2012- L1 Twin Doors.

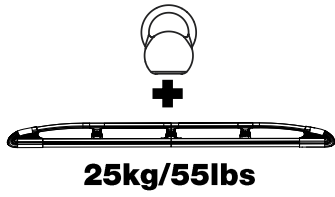

150kg
Max

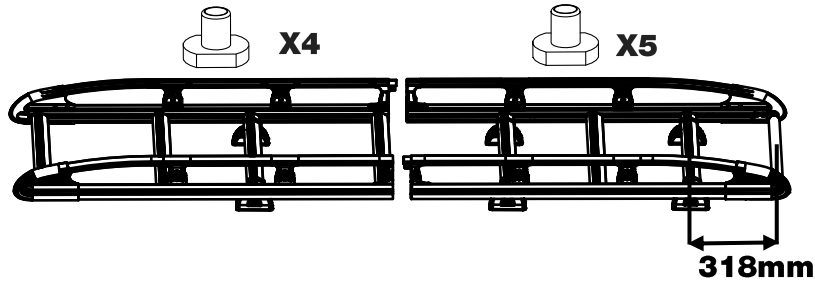
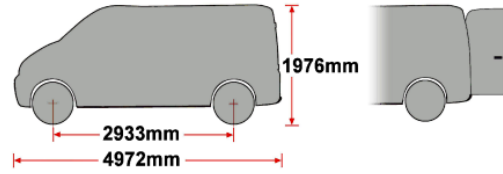

Steps 14-30, 53-62

A

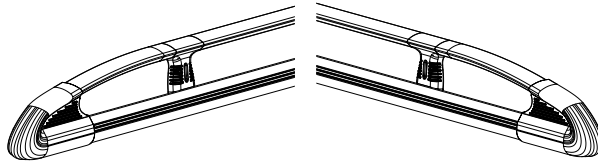

K650/B650- Ford Transit Custom 2012- L1, Tailgate.

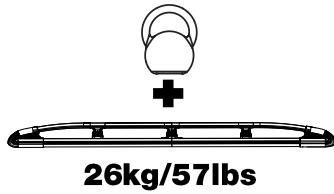

150kg
Max

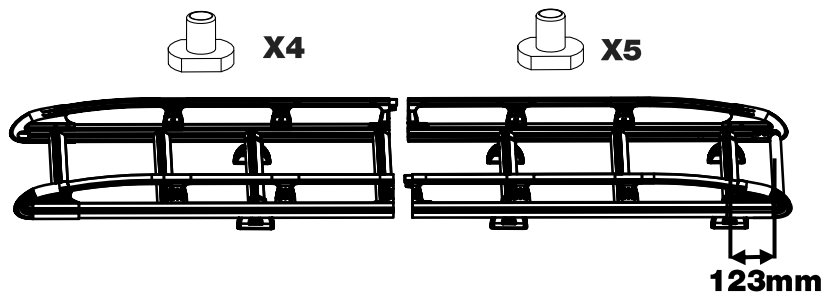
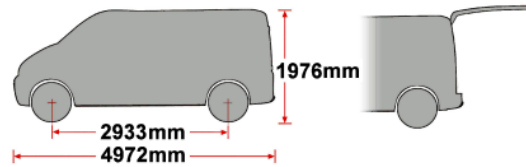

Steps 14-30, 53-62

A

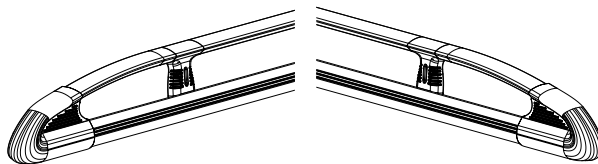

K651/B651- Ford Transit Custom 2012- L2, Tailgate.

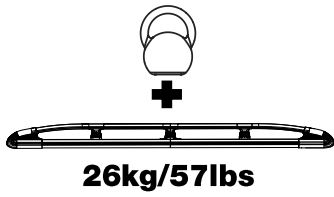

150kg Max

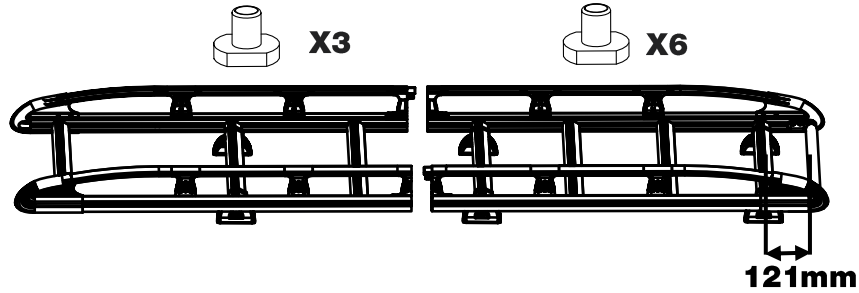
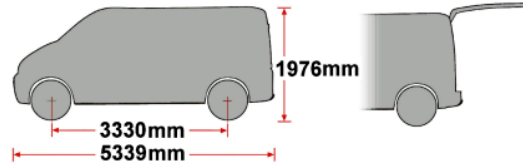

Steps 14-30, 53-62

A

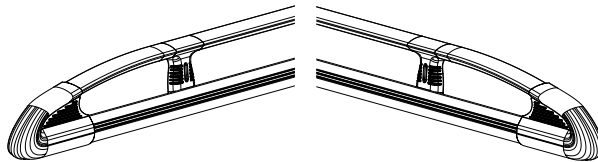

K616/B616- Ford Transit Custom 2012- L2, Twin Doors.

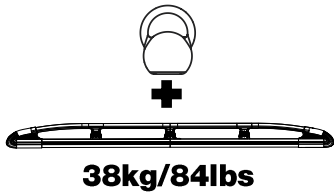

150kg Max

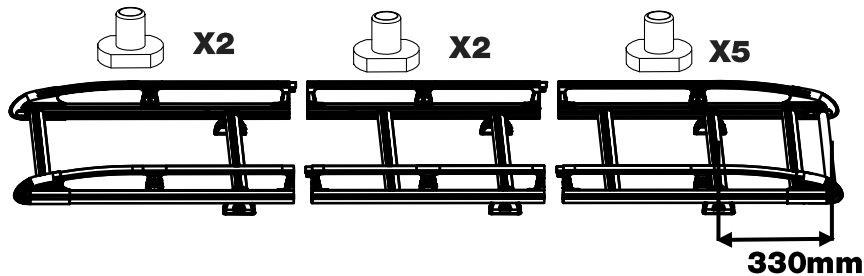
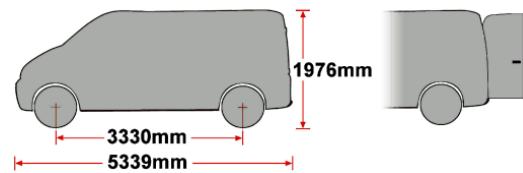

Steps 31-62

B

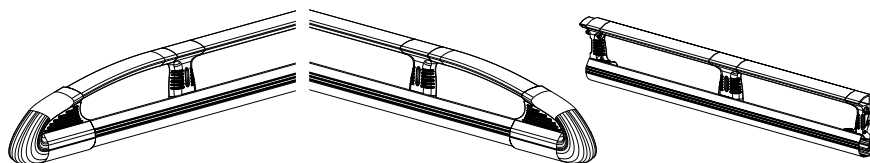

K615/B615- Ford Transit Custom 2023- L1 Twin Doors.

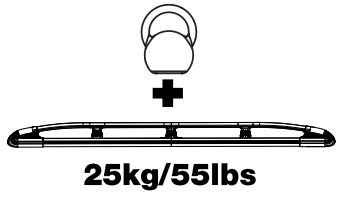

150kg Max

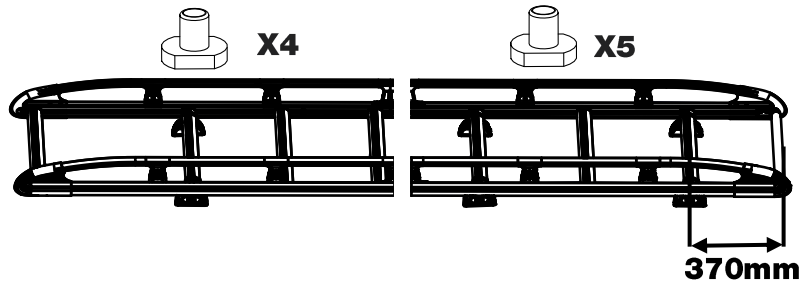
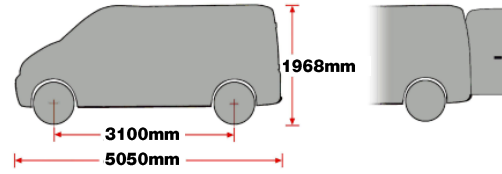

Steps 14-30, 53-62

A

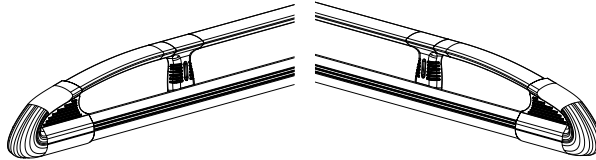

K650/B650- Ford Transit Custom 2023- L1, Tailgate.

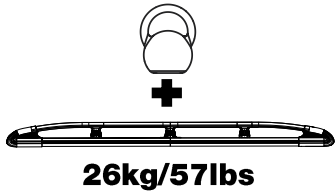

150kg Max

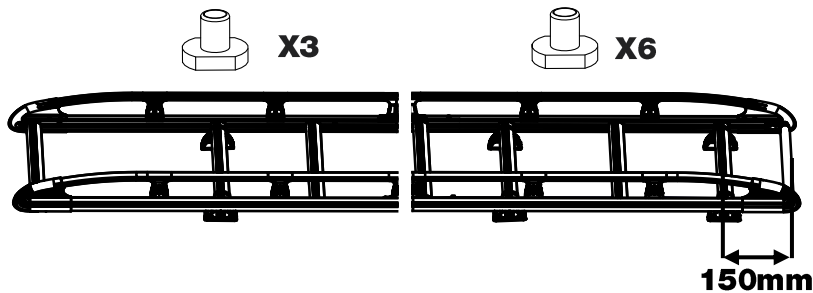
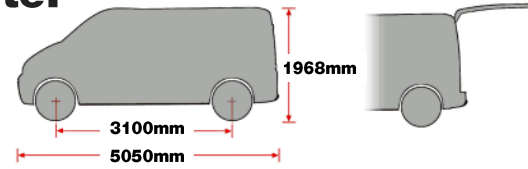

Steps 14-30, 53-62

A

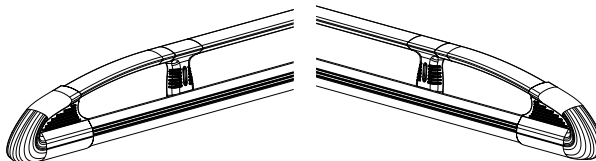

K651/B651- Ford Transit Custom 2023- L2, Tailgate.

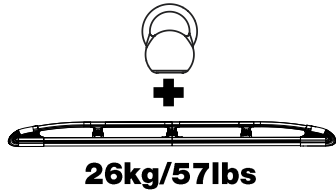

150kg Max

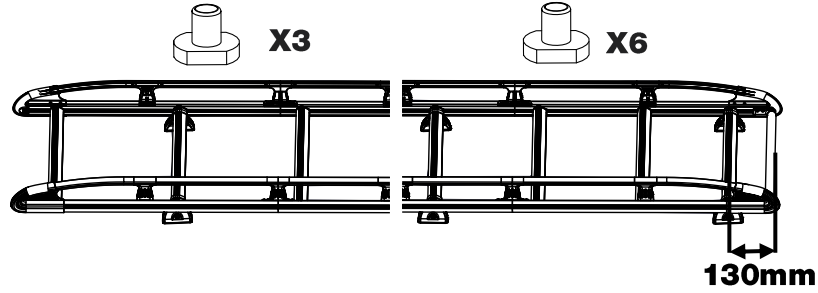
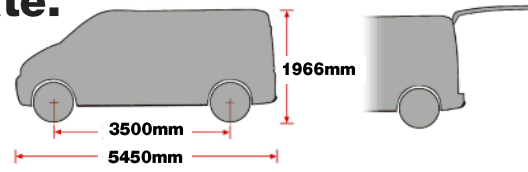

Steps 14-30, 53-62

A

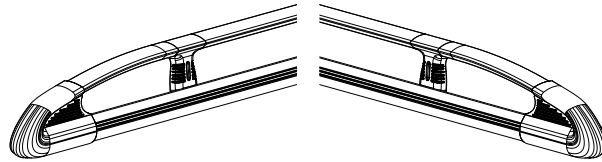

K616/B616- Ford Transit Custom 2023- L2, Twin Doors.

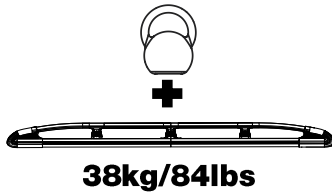

150kg Max

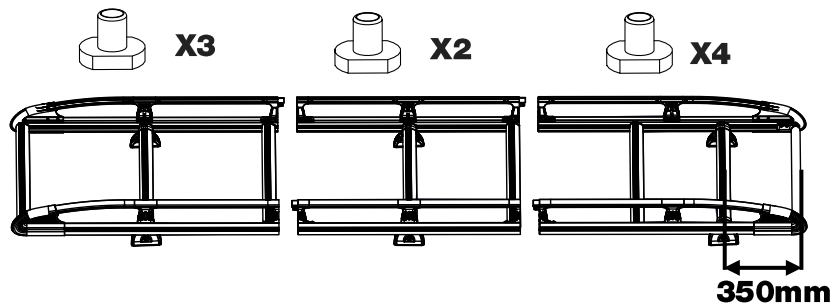
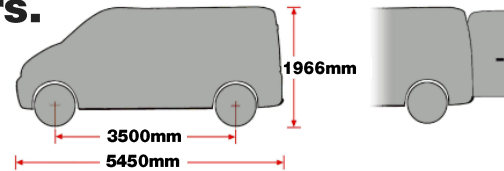

Steps 31-62

B

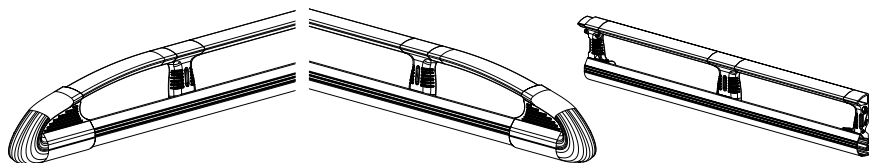

14.

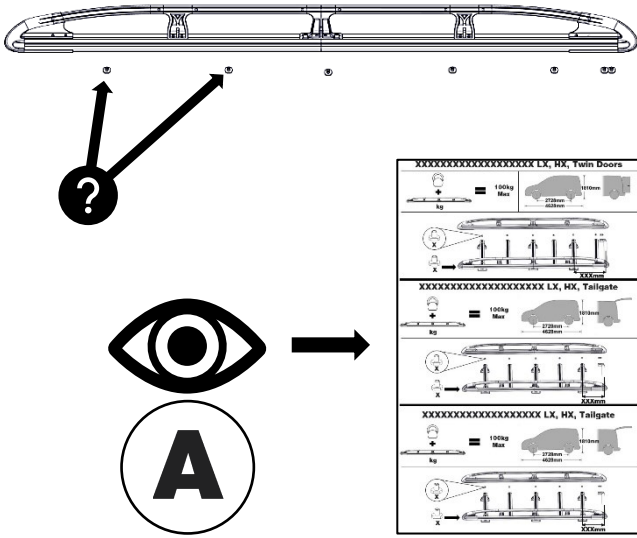

15.

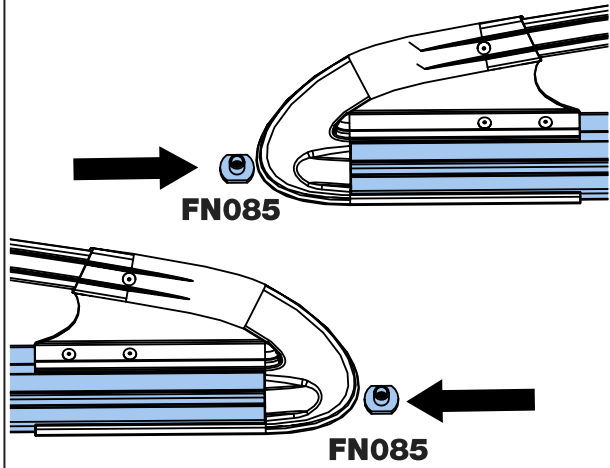

16.

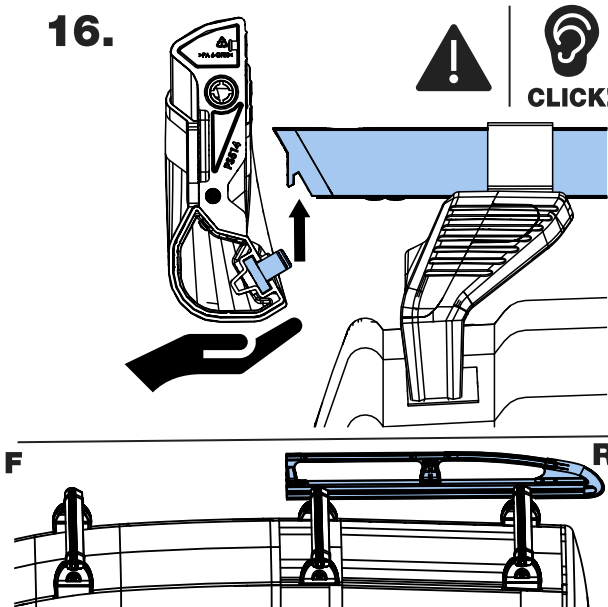

17.

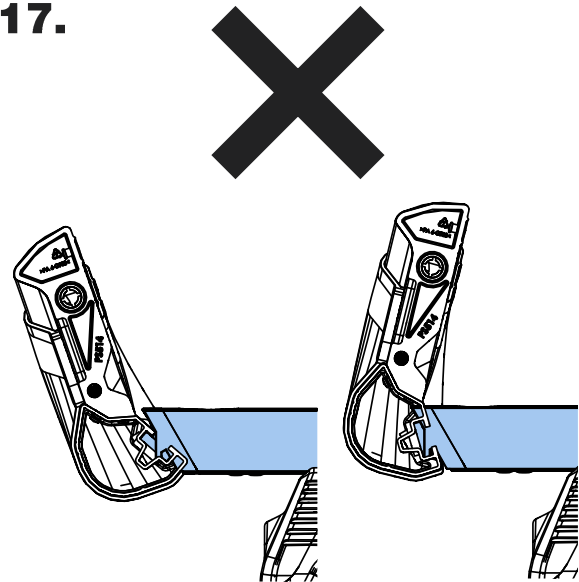

18.

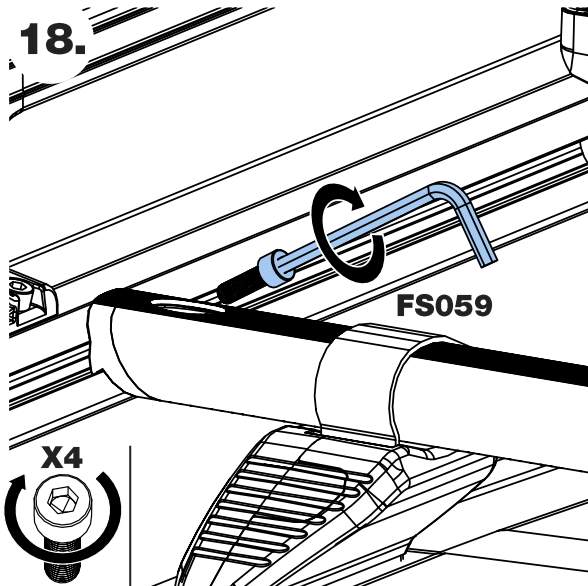

19.

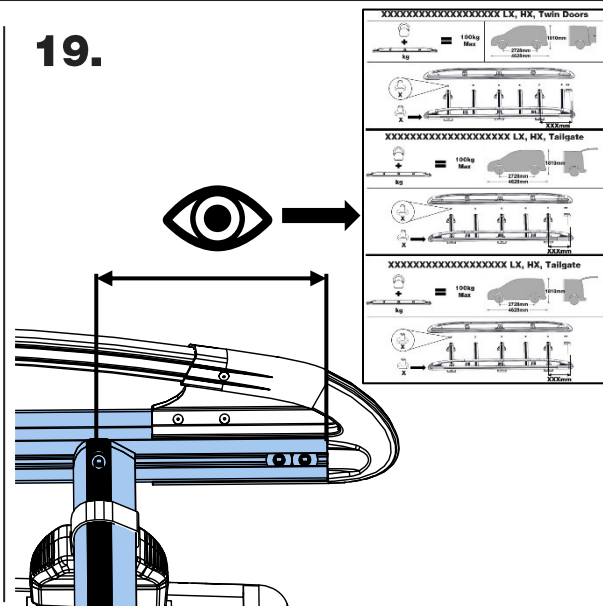

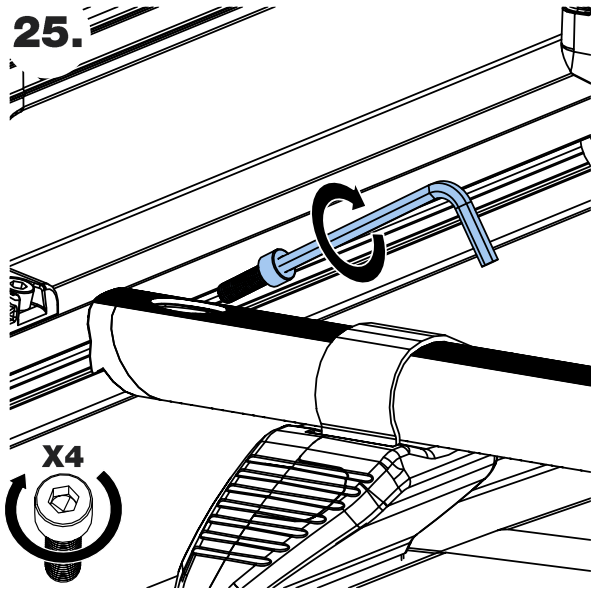
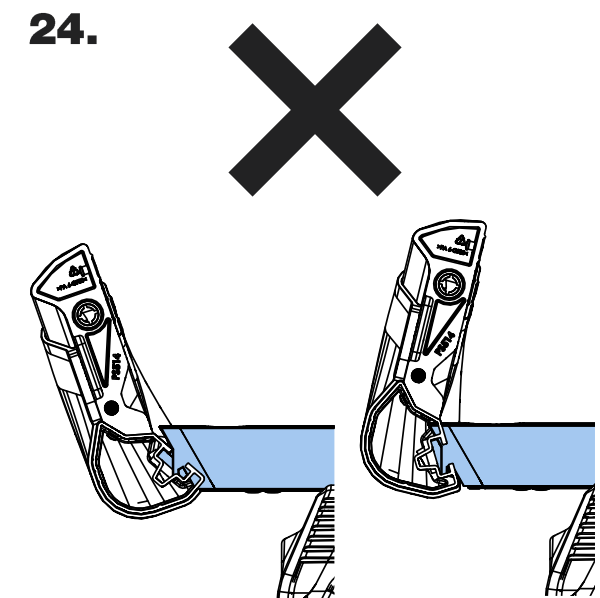
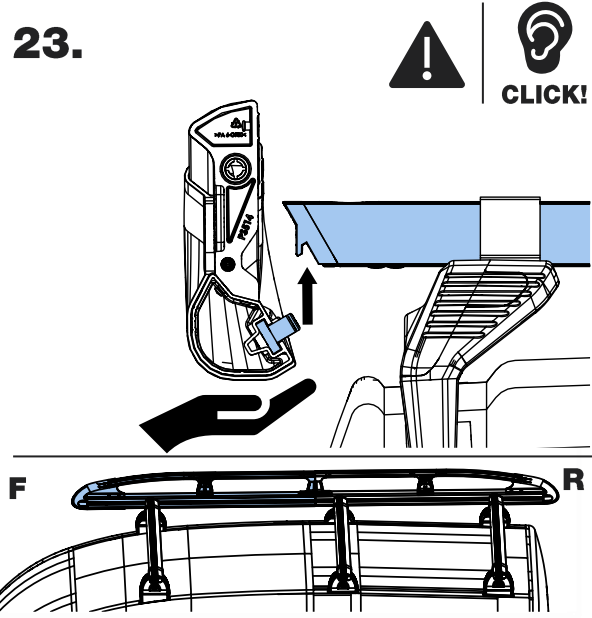
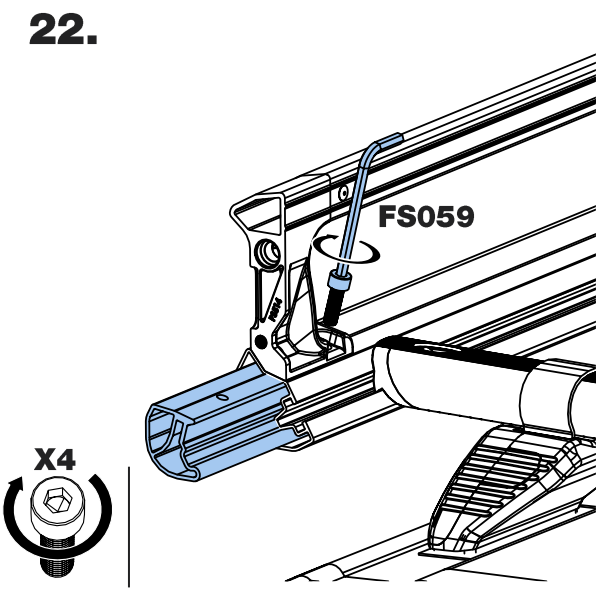
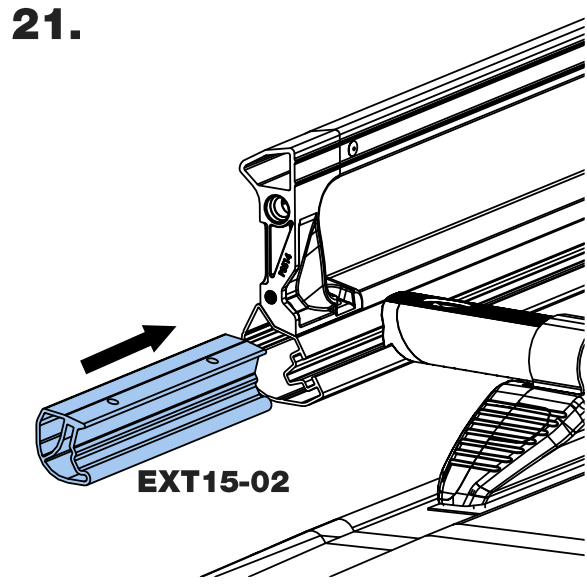
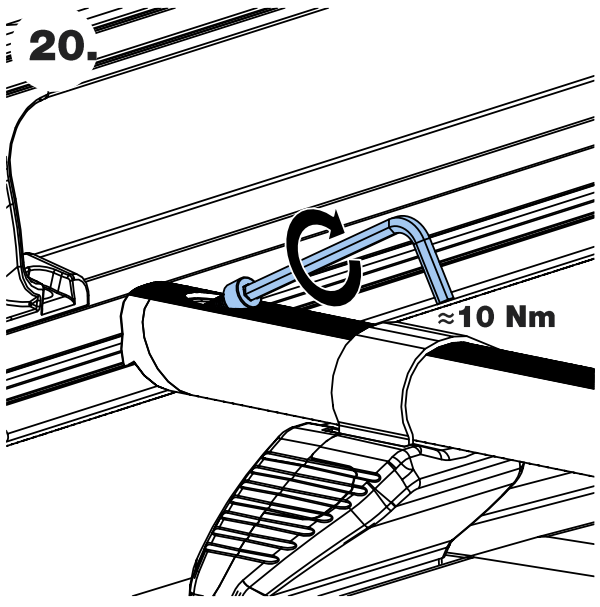

26.

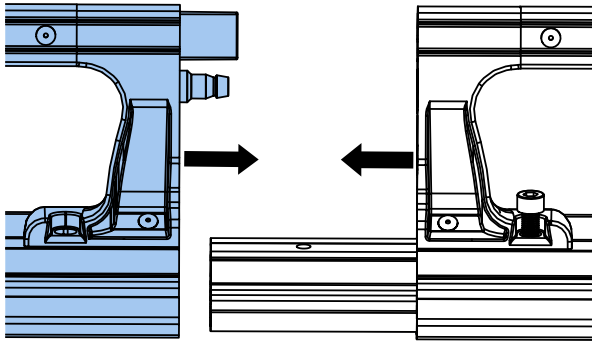

27.

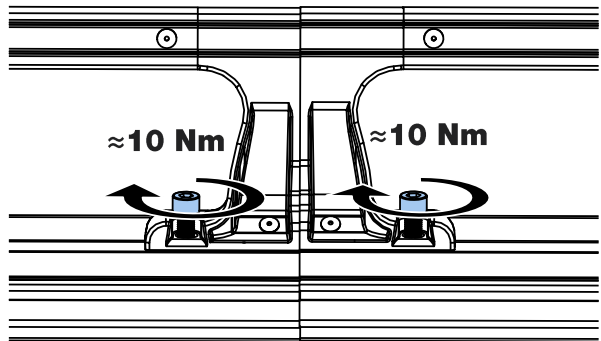

28.

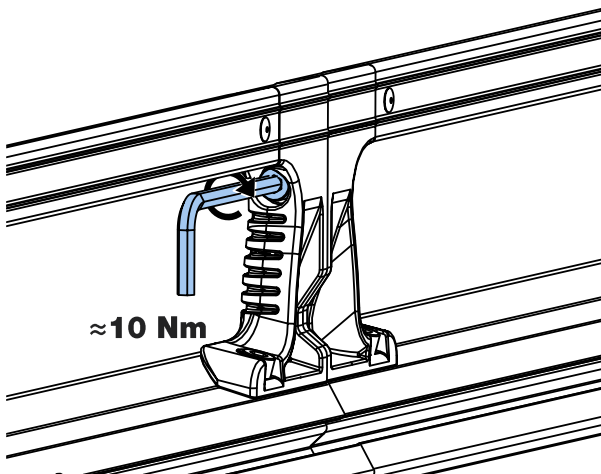

29.

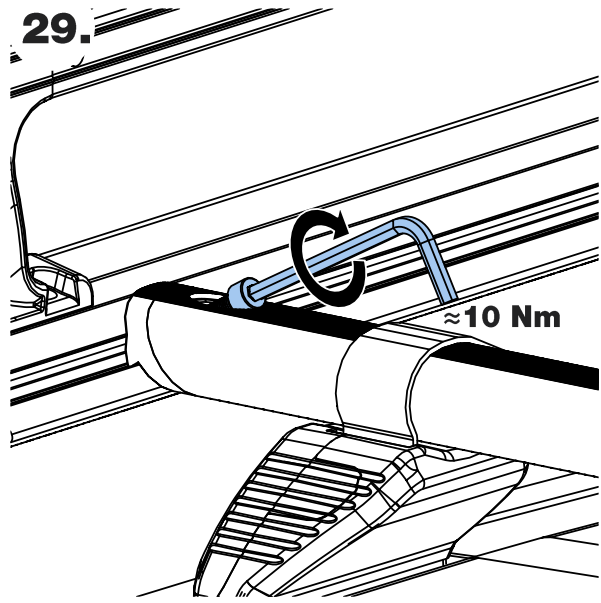

30.

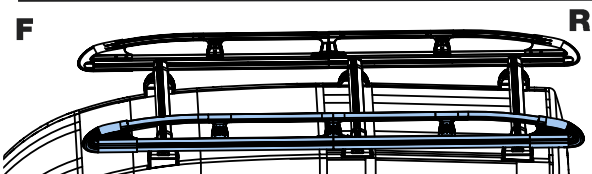
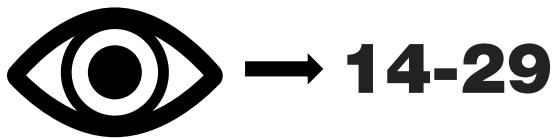

31.

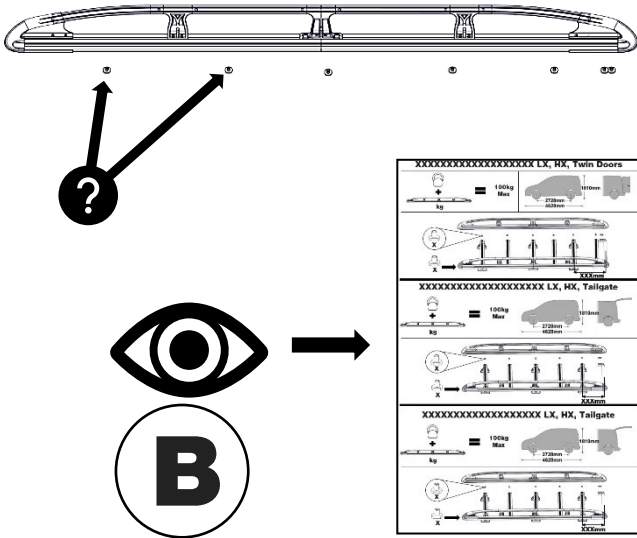

32.

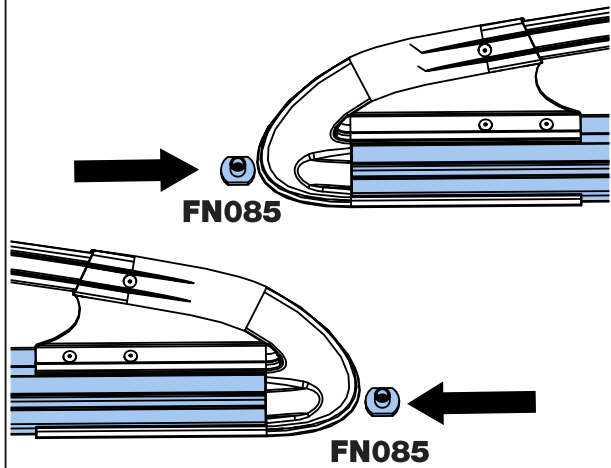

33.

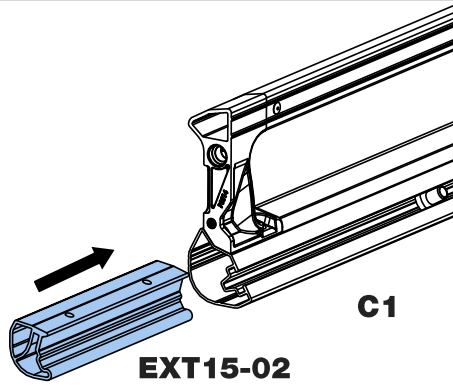

34.

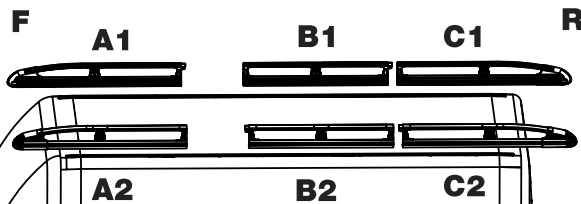
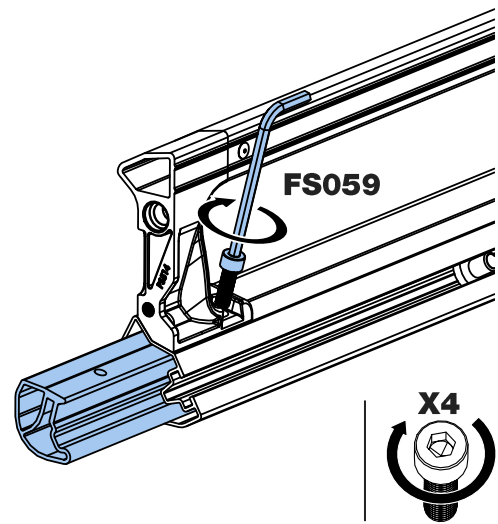

35.

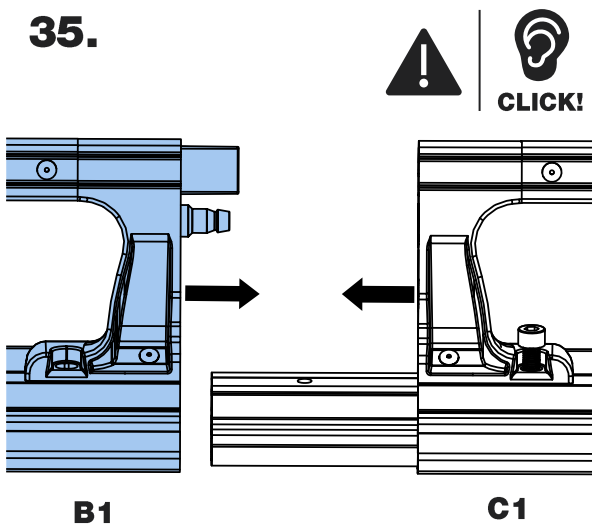

36.

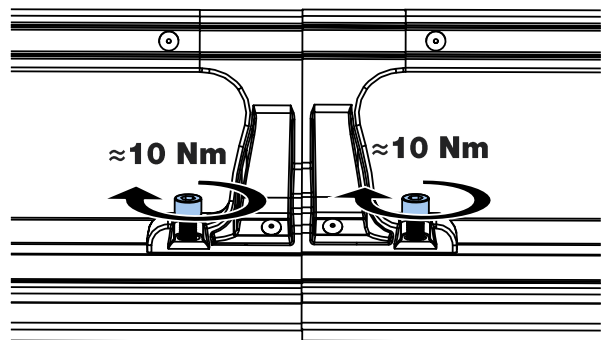

37.

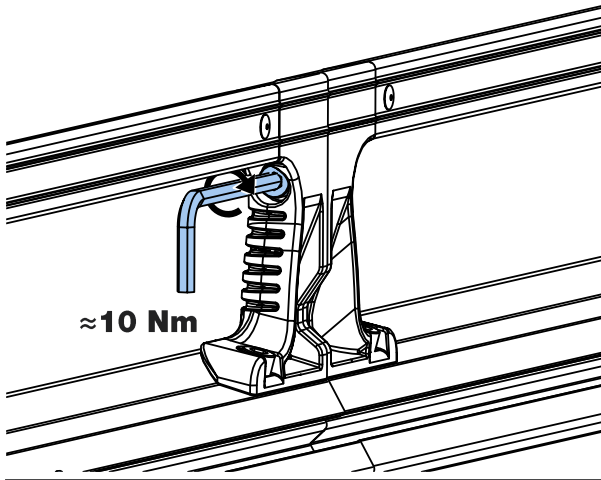

38.

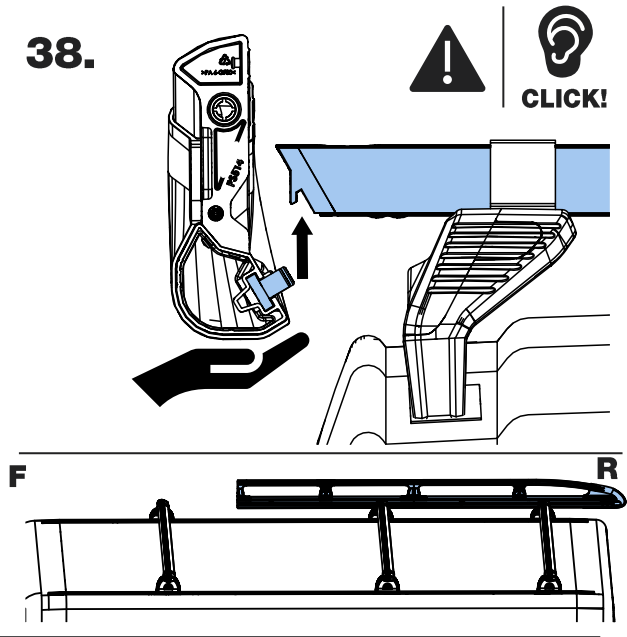

39.

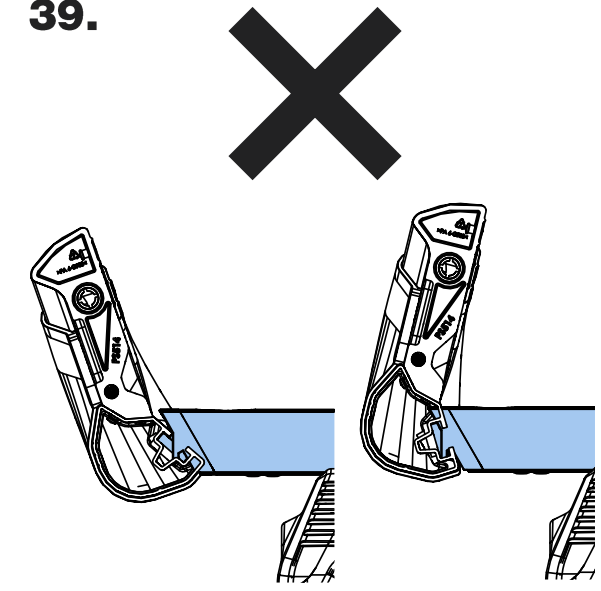

40.

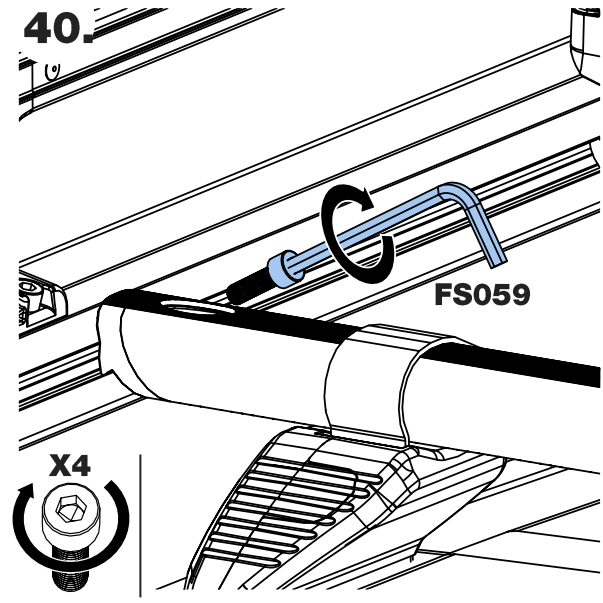

41.

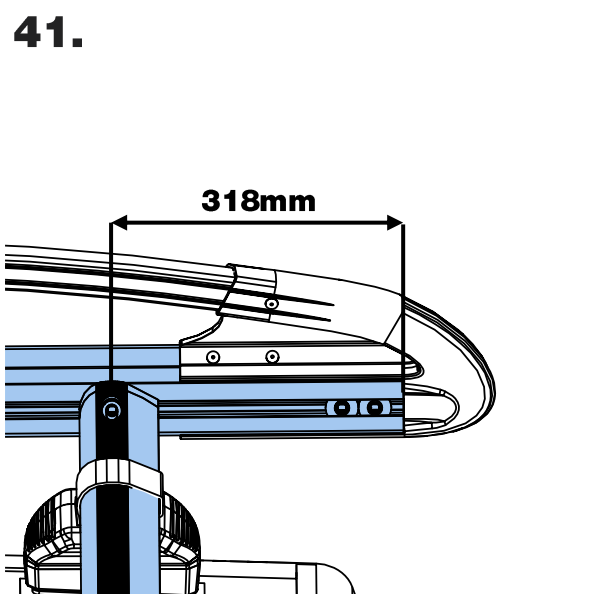

42.

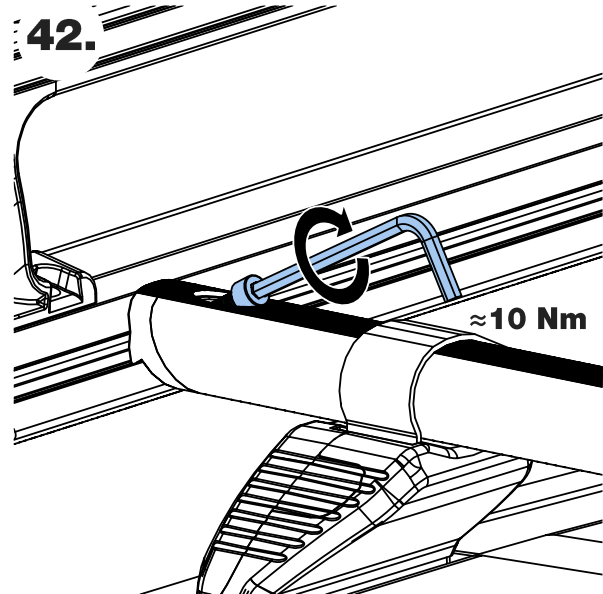

43.

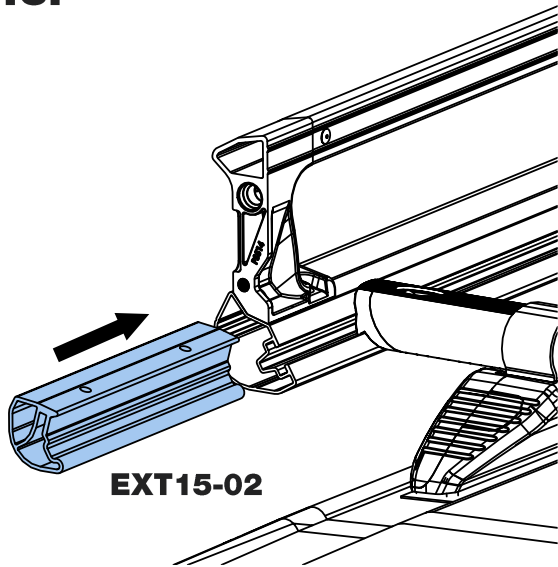

44.

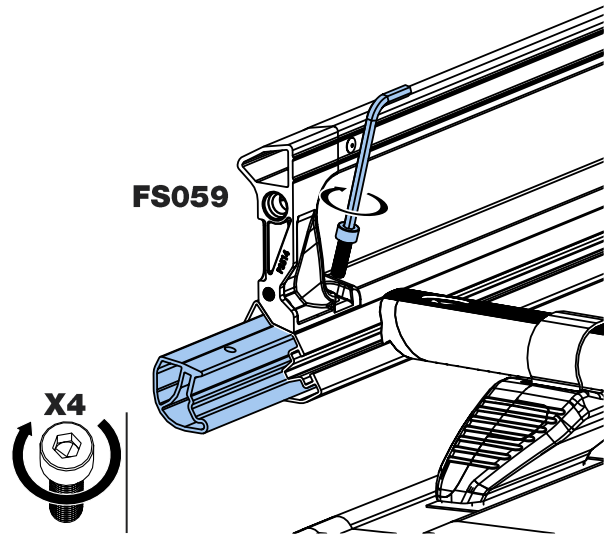

45.



46.

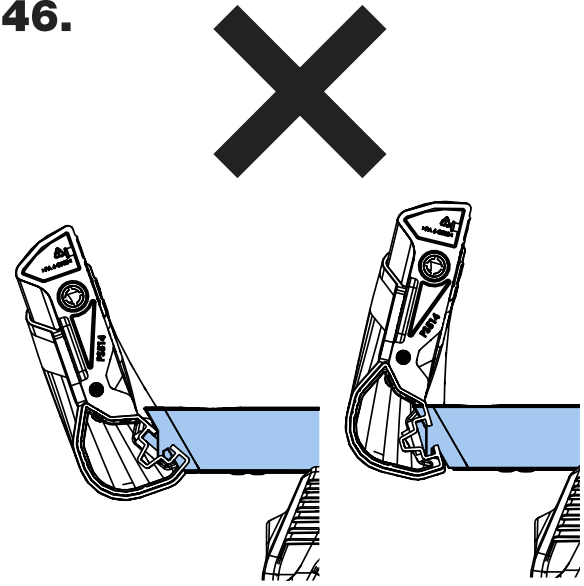

47.

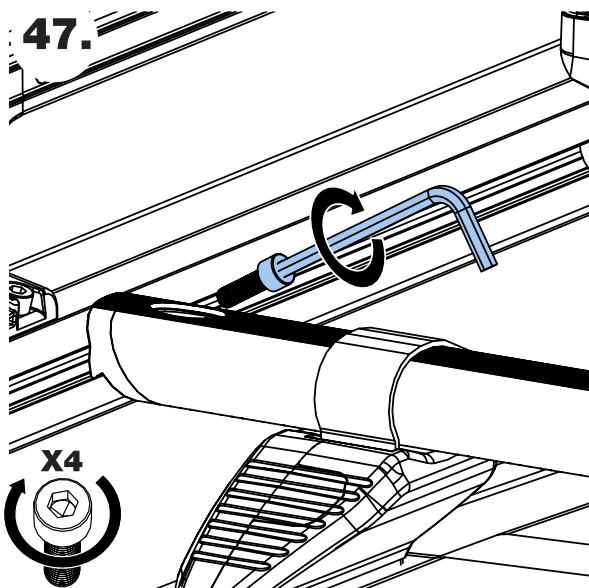

48.

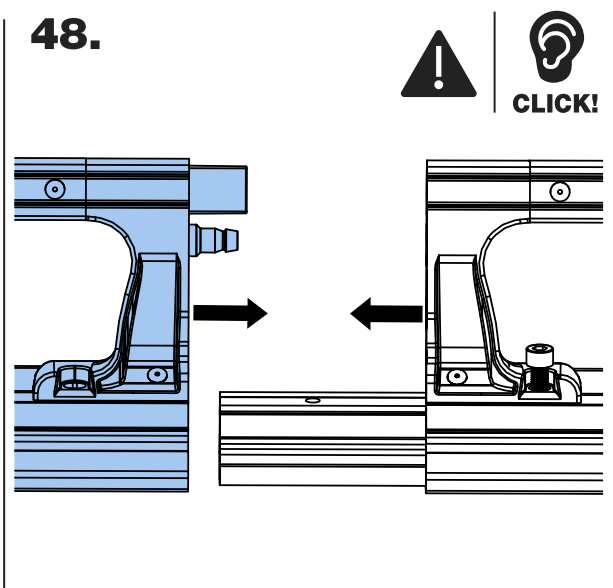

49.

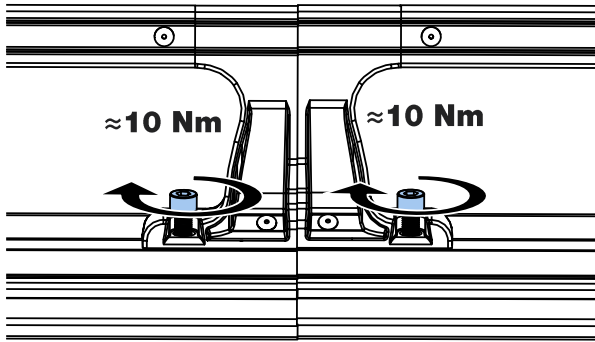

50.

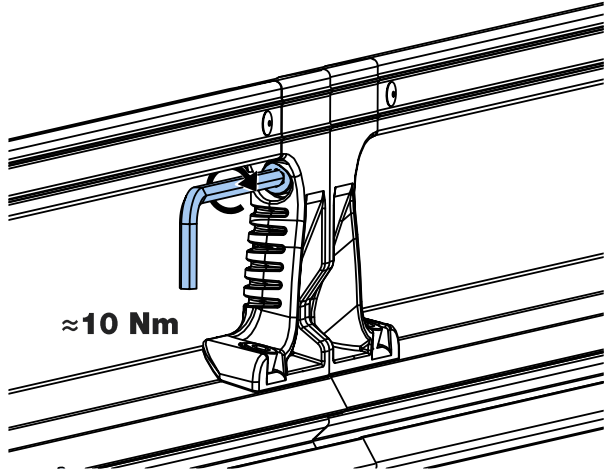

51.

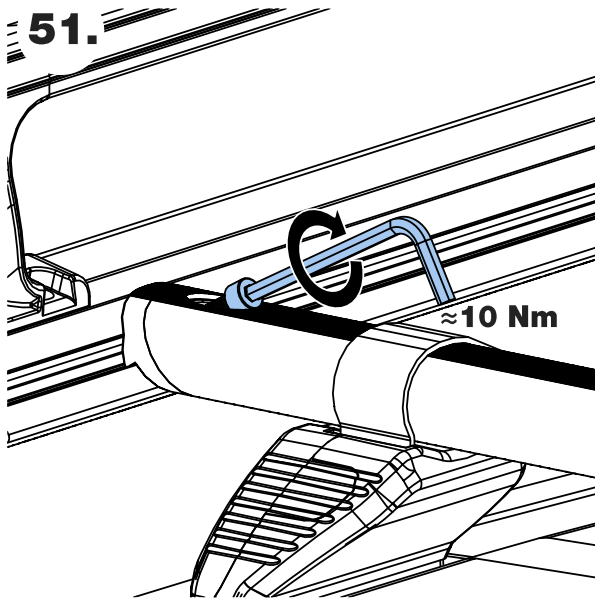

52.

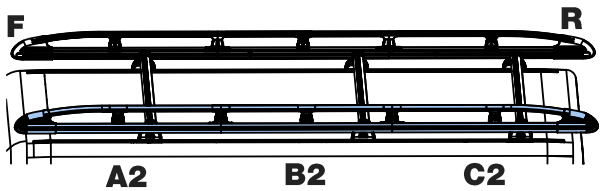
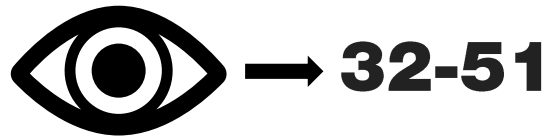

53.

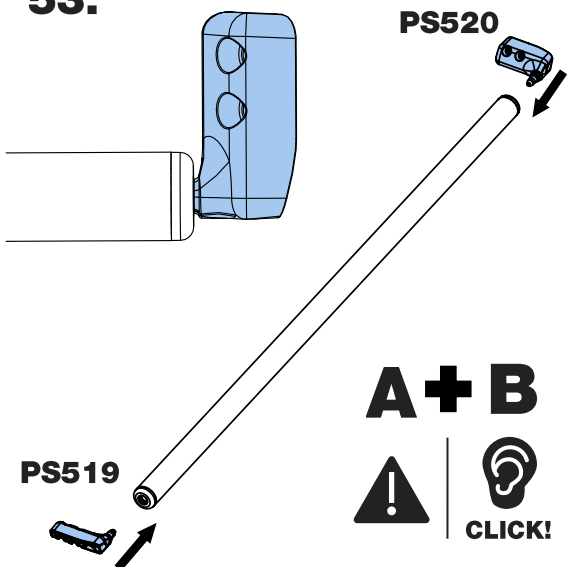

54.

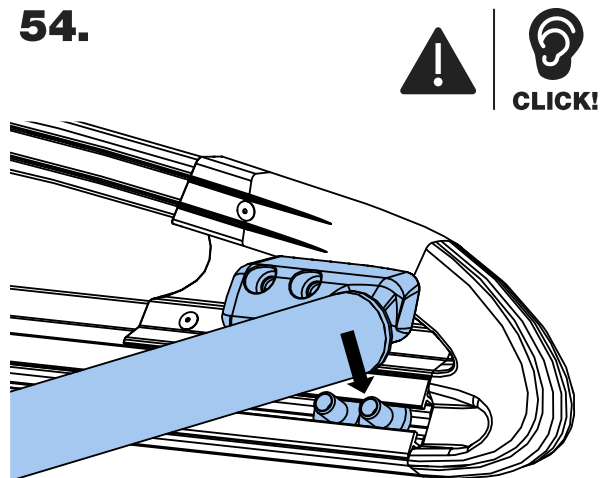

55.

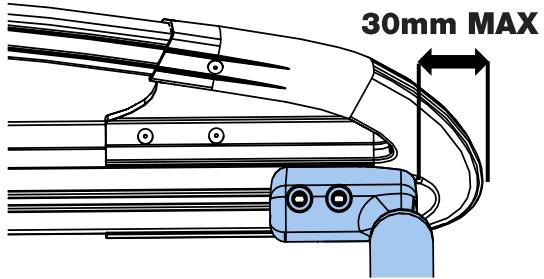

56.

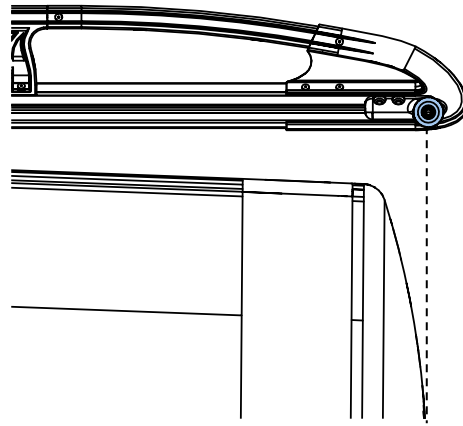

57.

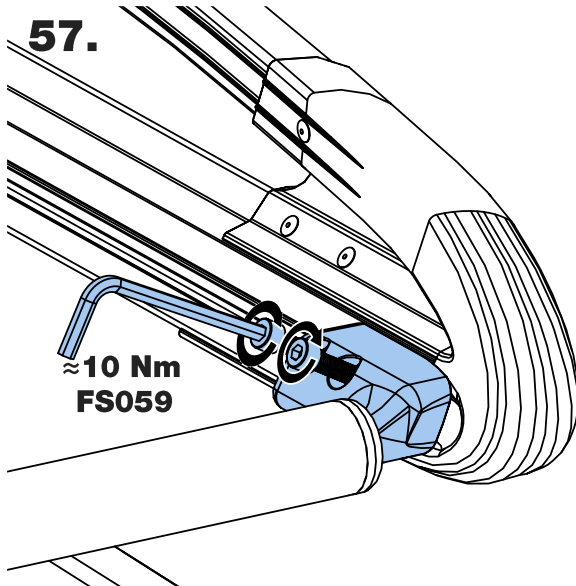

58.

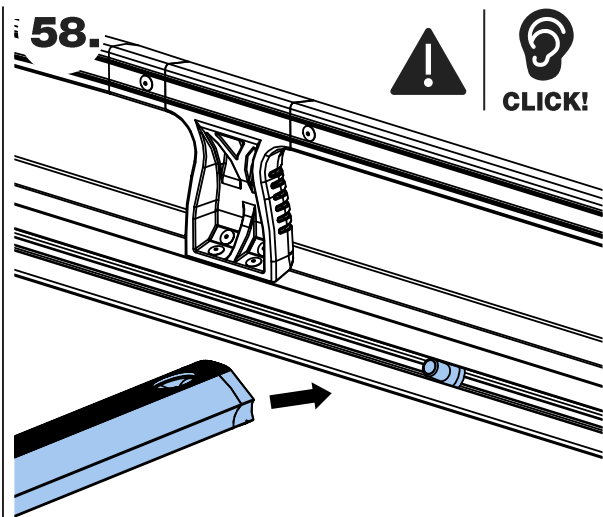

59.

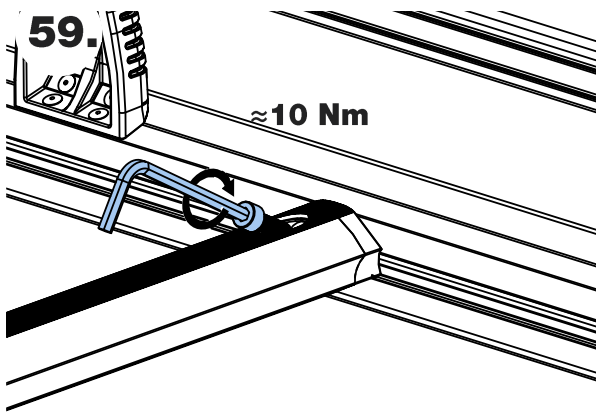

60.

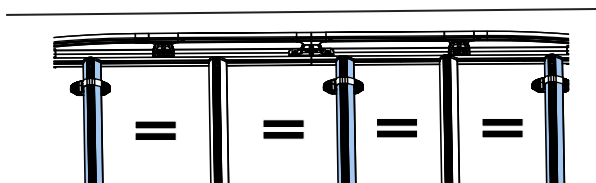
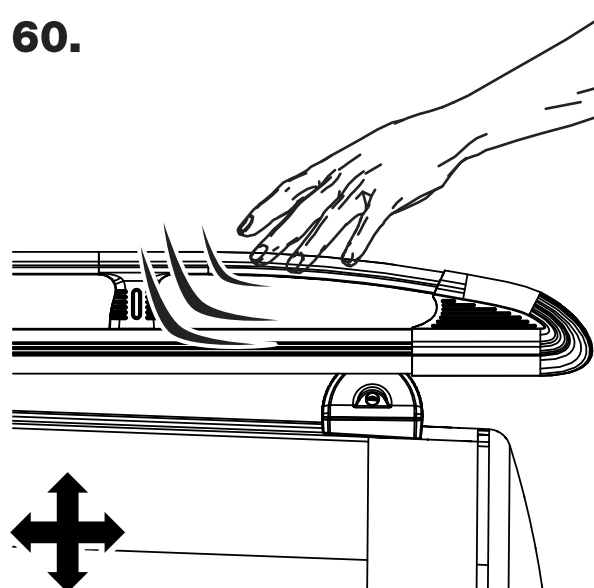

61.

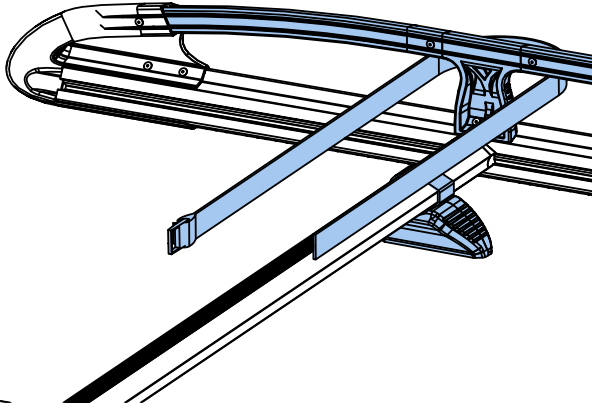

62.

