

MC5KR

KammRack

Instructions

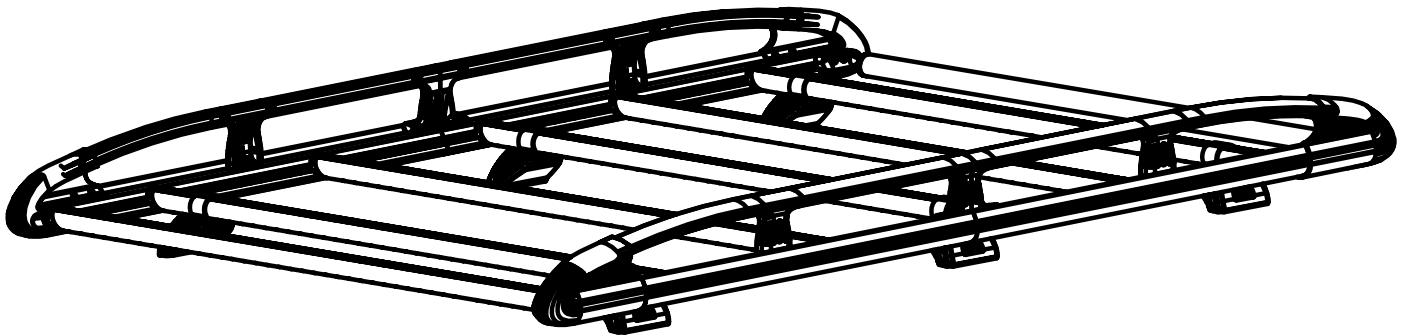

CITY CRASH (✓)

According to ISO/ PAS 11154:2006

MC5KR:

MERCEDES Sprinter 2006-
VW Crafter 2006-2017-
VW Crafter 2017-

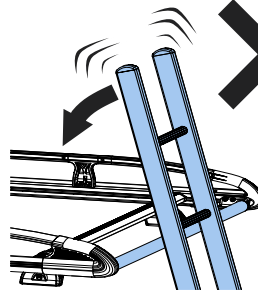
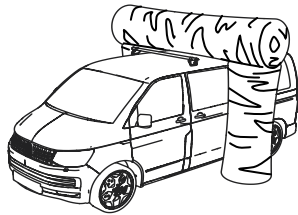
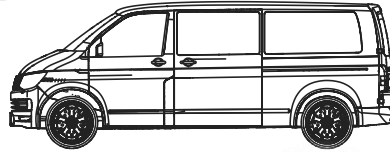

Max
50kg/110lbs

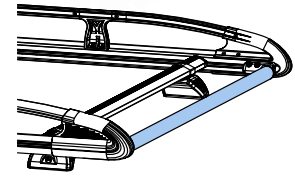

KammRack

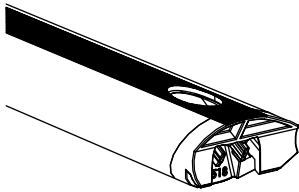

**SA430/
SA468**

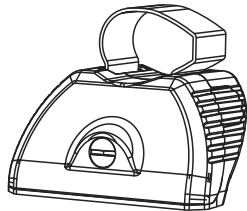

SA398U x 5

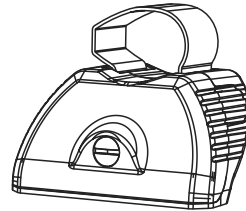

SA397U x 5



C04 x 10
optional upgrade

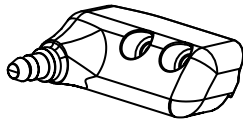

PS519 x 1

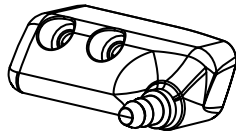

PS520 x 1

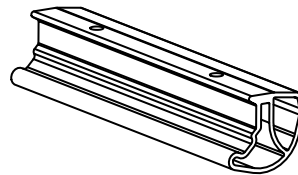

EXT15-02

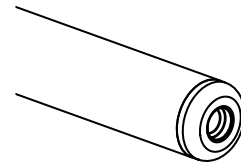

SA438 x 1

LHS x 2

RHS x 2

Centre

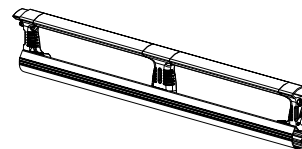
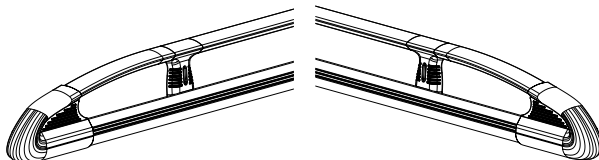

ASF x 1

Fitting Kit

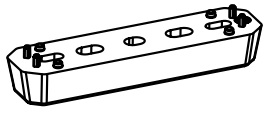

PS183 x 10

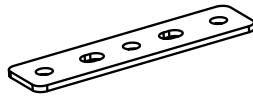

PS023 x 10

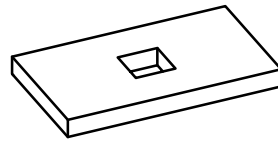

MS209 x 20

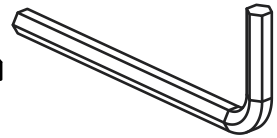

FT01 x 1

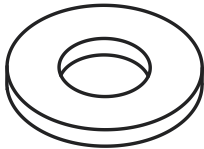

FW002 (M8) x 20

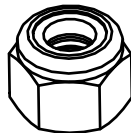

FN006 (M8) x 20

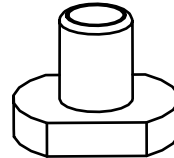

FN085 x 26

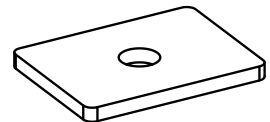

PS020 x 10

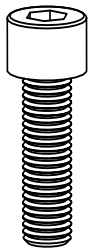

FS018
(M8 x 25) x 26

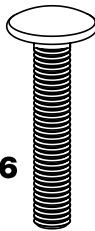

FS134
(M8 x 45) x 20

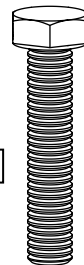

FS081
(M8 x 50) x 10

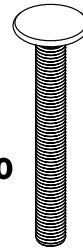

FS293
(M8 x 65) x 20

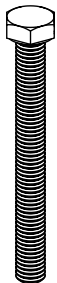

FS107
(M8 x 75) x 10

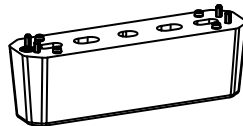

PS325 x 10



FT05 x 1

K521/B521- Sprinter/Crafter 2006- L3, H2, Twin Doors

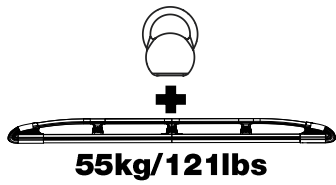

150kg Max

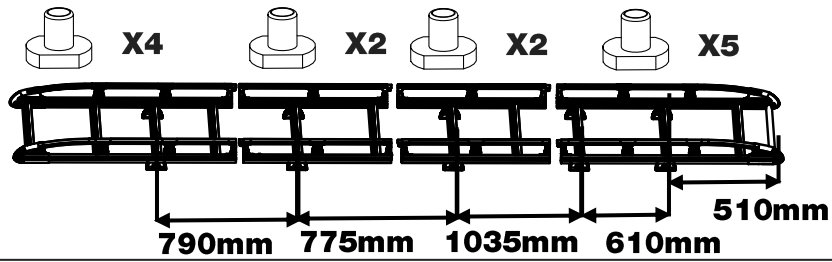
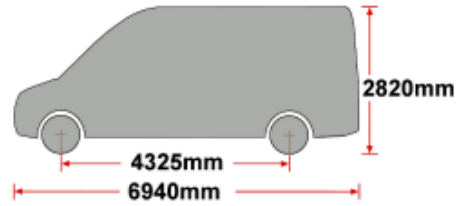

A

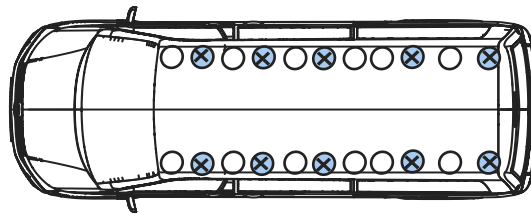

K522/B522- Sprinter/Crafter 2006- L4, H2, Twin Doors

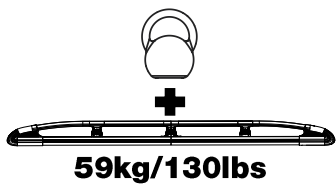

150kg Max

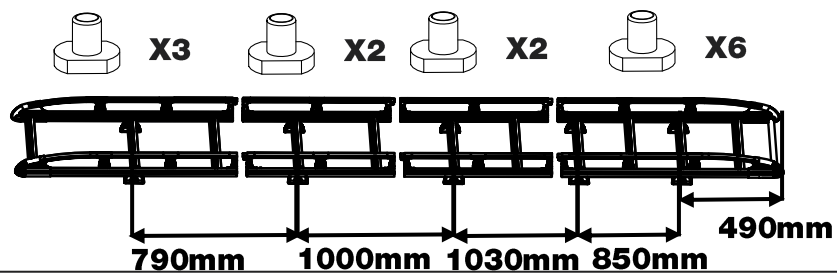
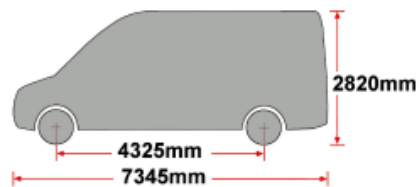

B

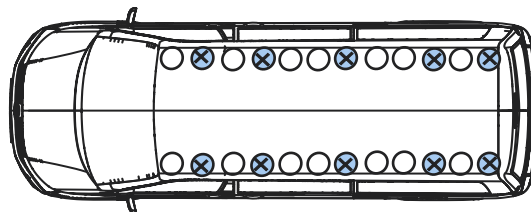

1. A+B

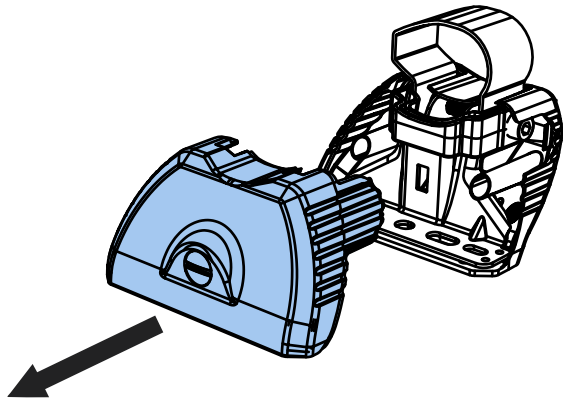

2.

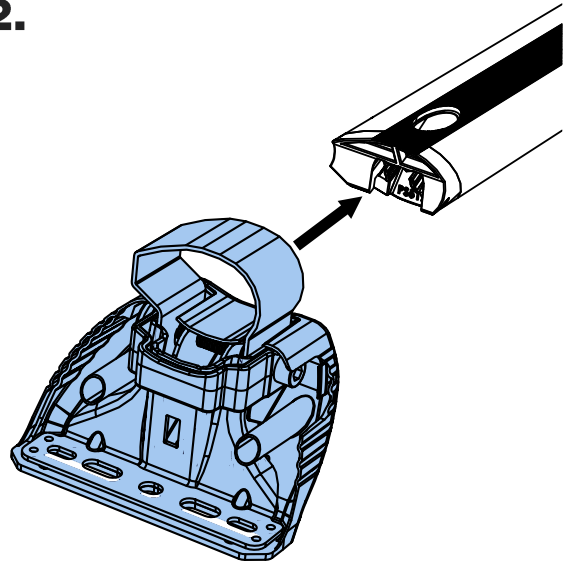

3.

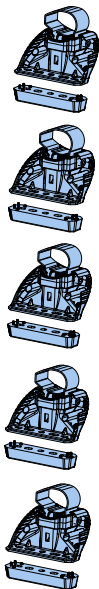

**SA397U
PS183/PS325**

**SA397U
PS183/PS325**

**SA397U
PS183/PS325**

**SA397U
PS183/PS325**

**SA397U
PS183/PS325**

R

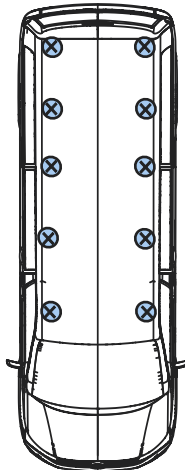

F

**SA398U
PS183/PS325**

**SA398U
PS183/PS325**

**SA398U
PS183/PS325**

**SA398U
PS183/PS325**

**SA398U
PS183/PS325**



4.

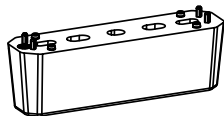

PS325

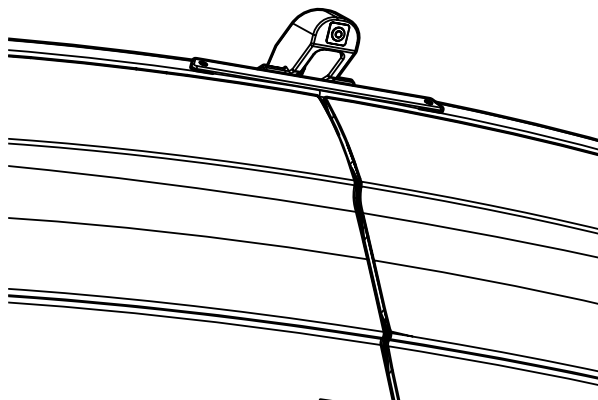

5.

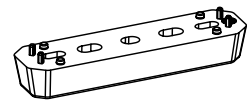

PS183

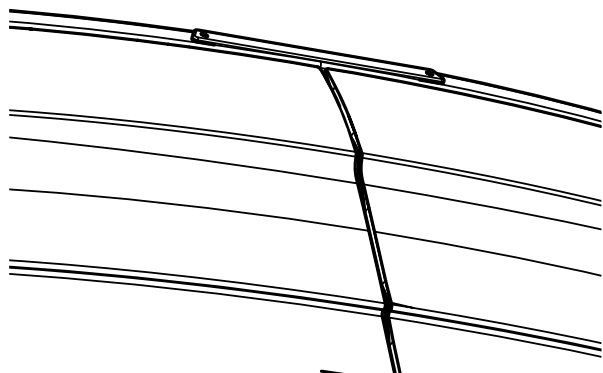

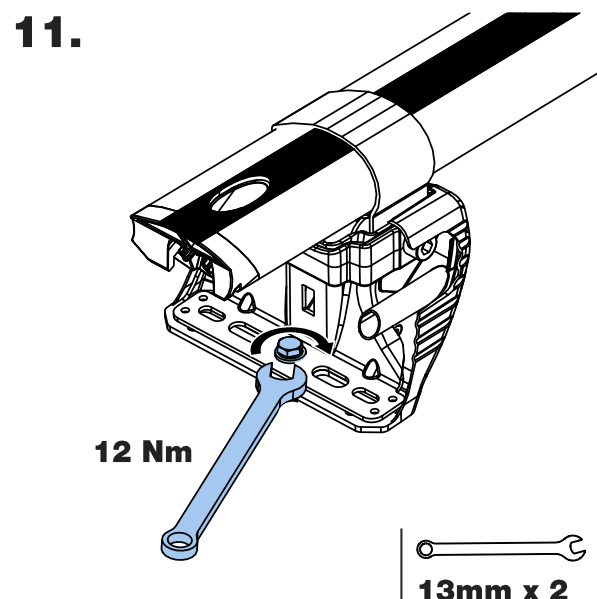
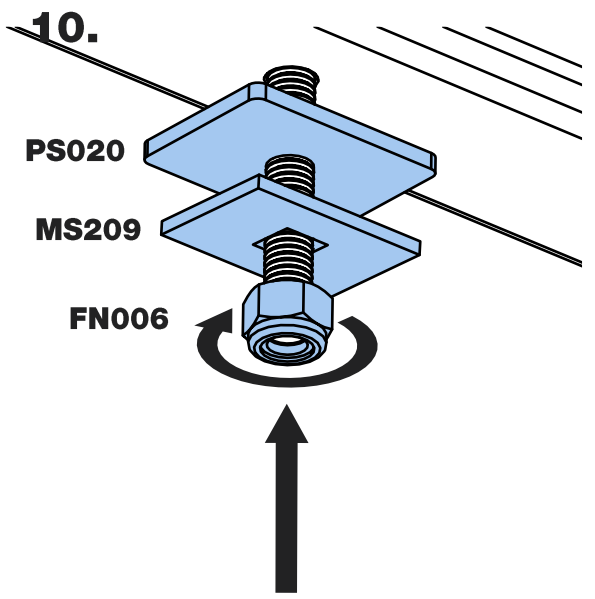
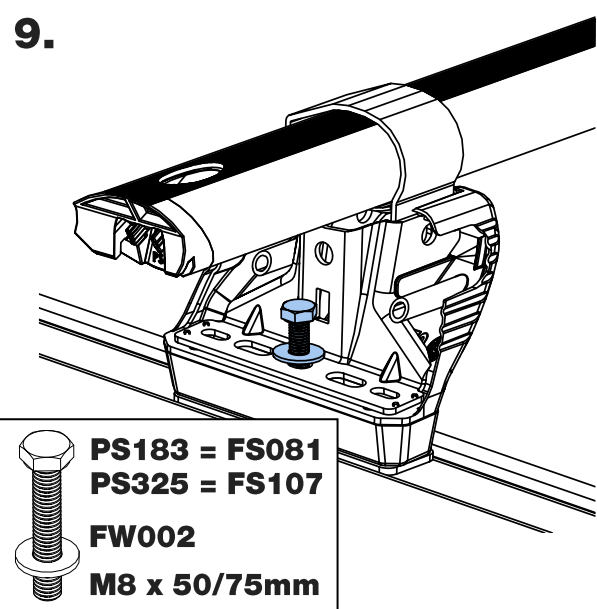
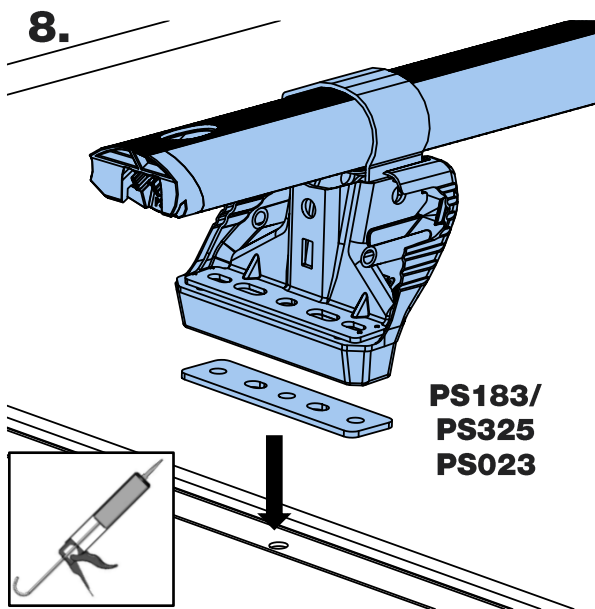
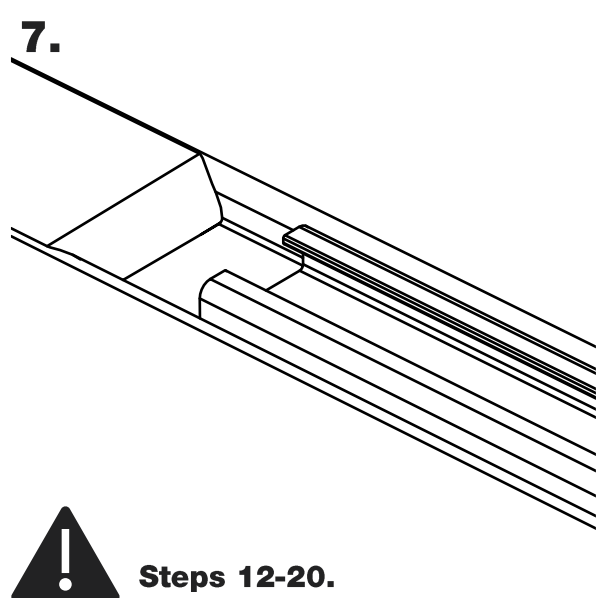
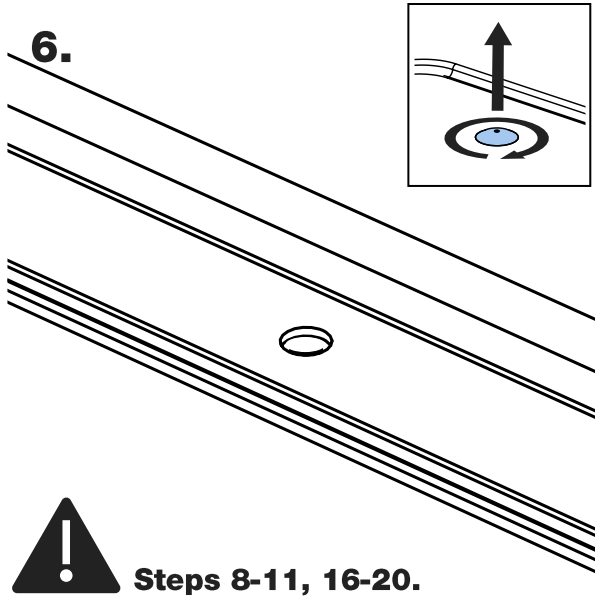

12.

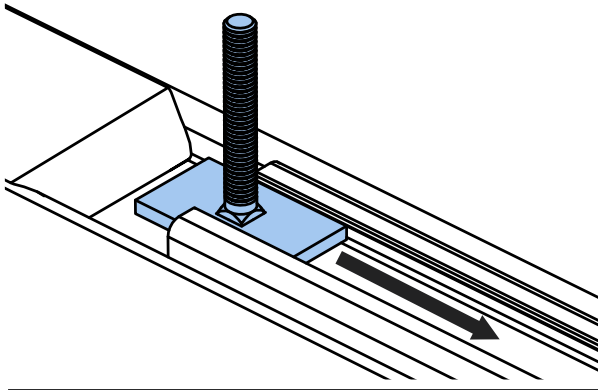
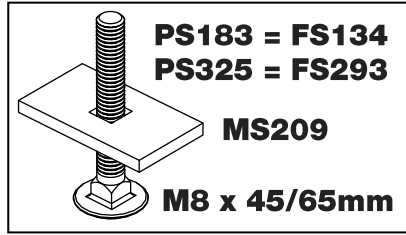

13.

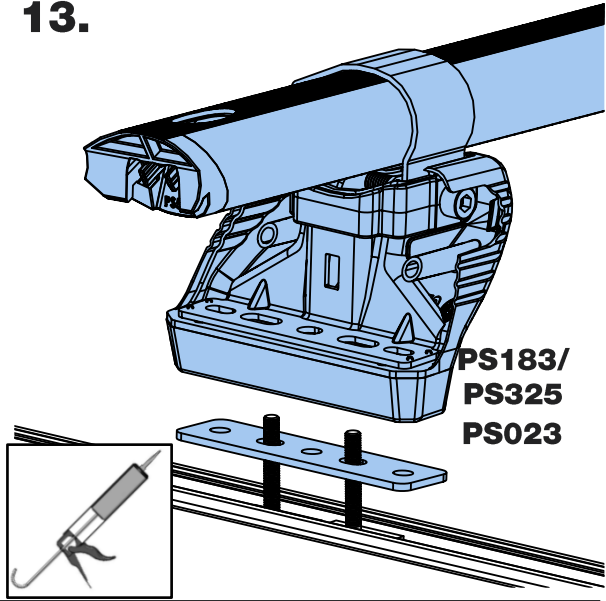

14.

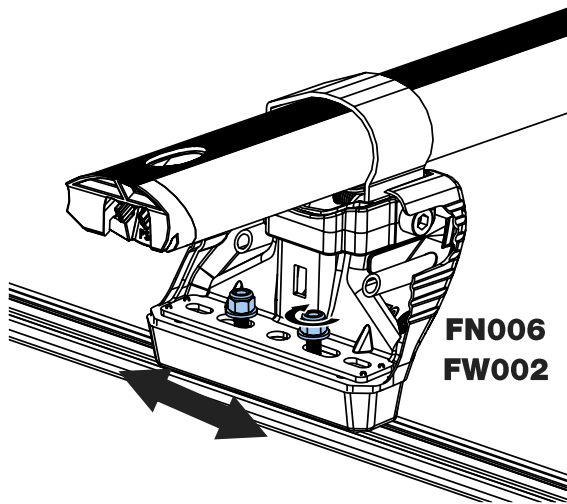

15.

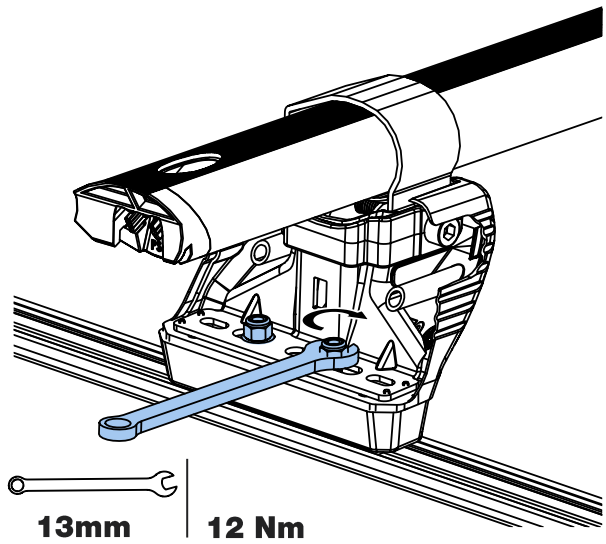

16.

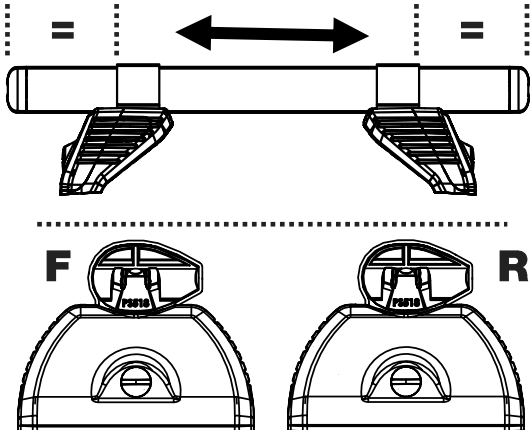

17.

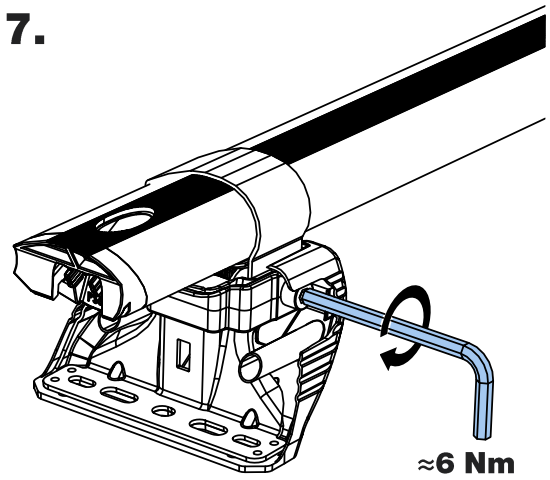

18.

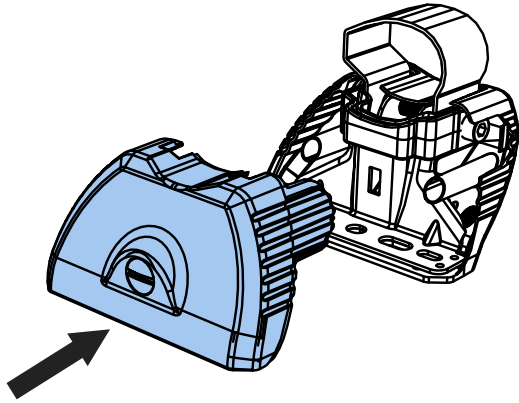

19.

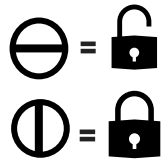
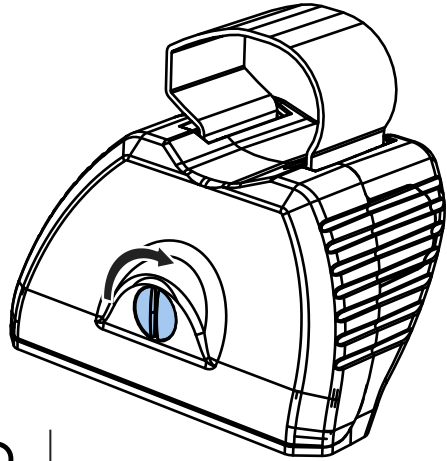

20.

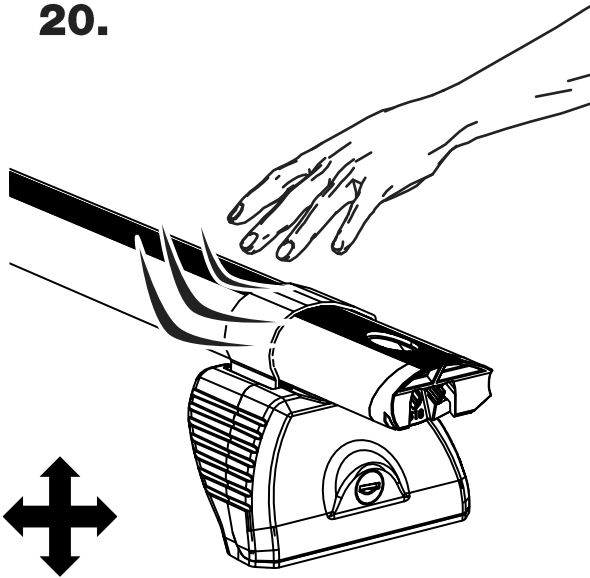

21.

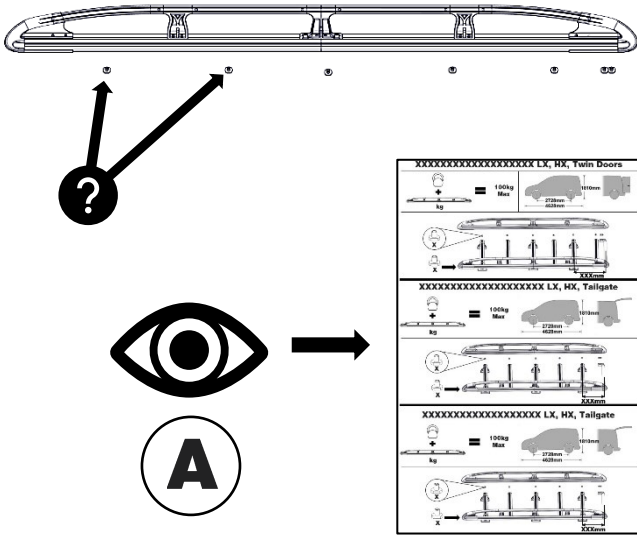

22.

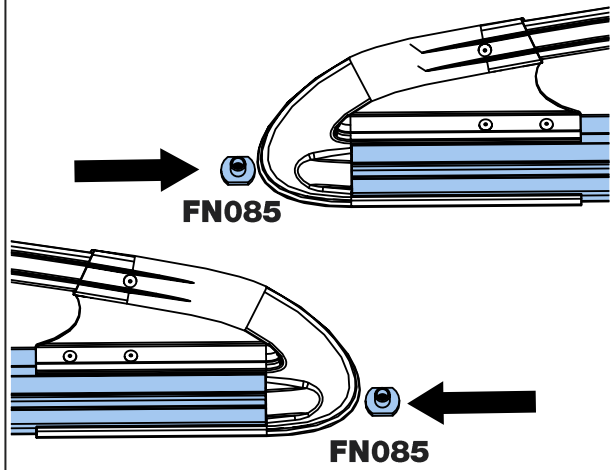

21.

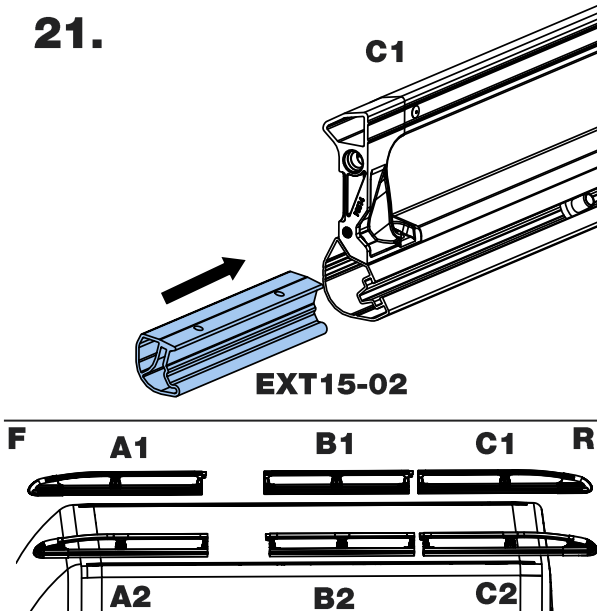

22.

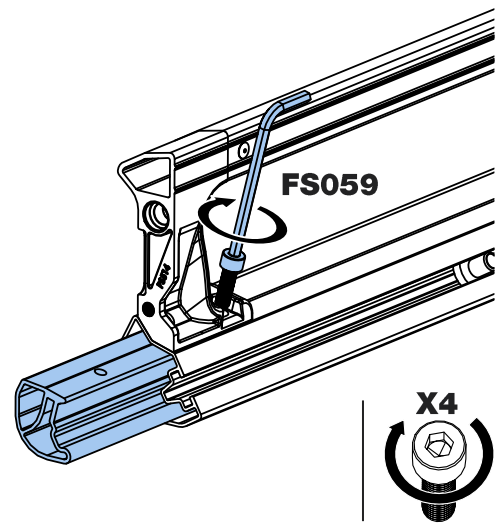

23.

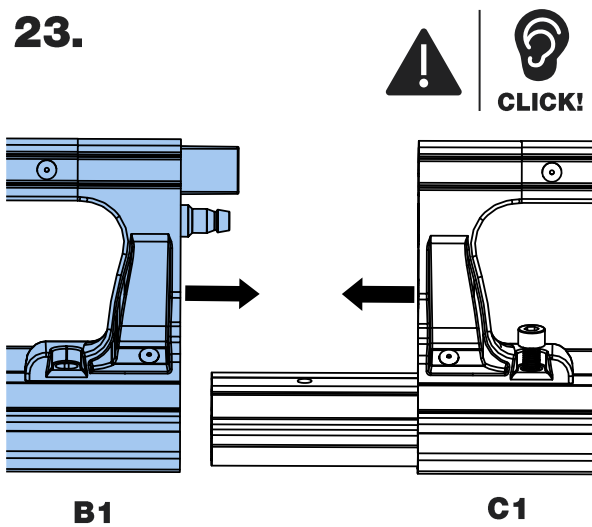

24.

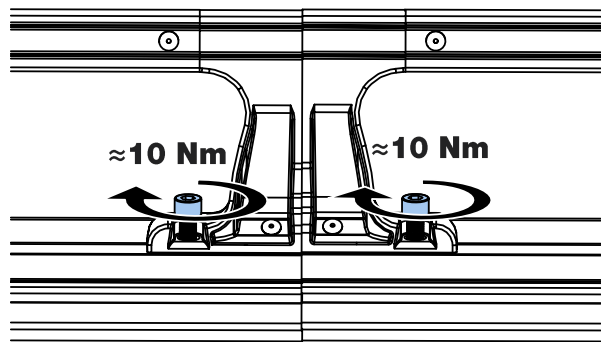

25.

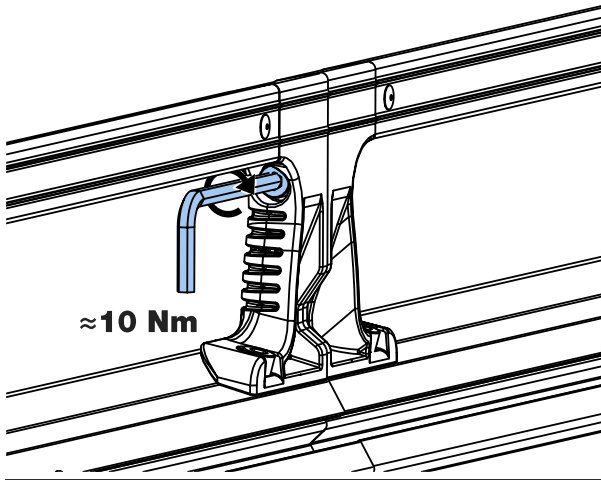

26.

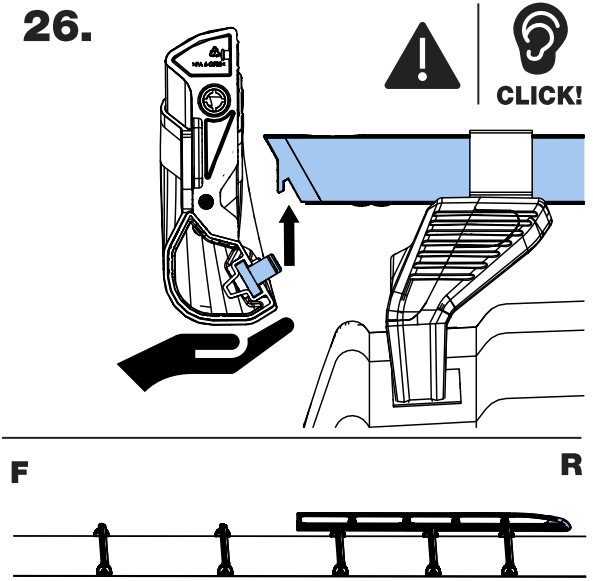

27.

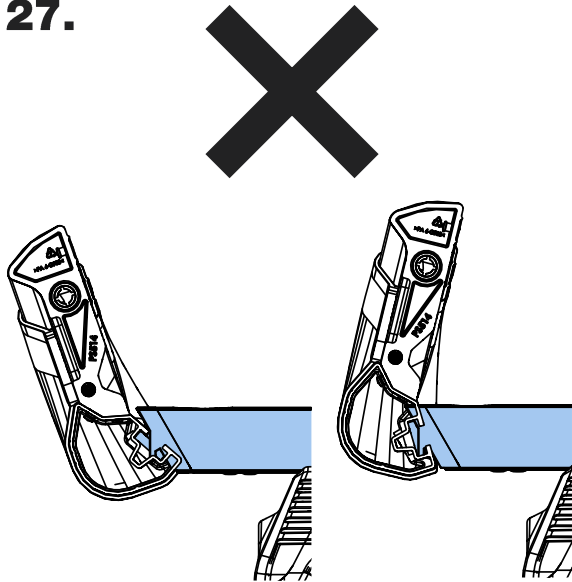

29.

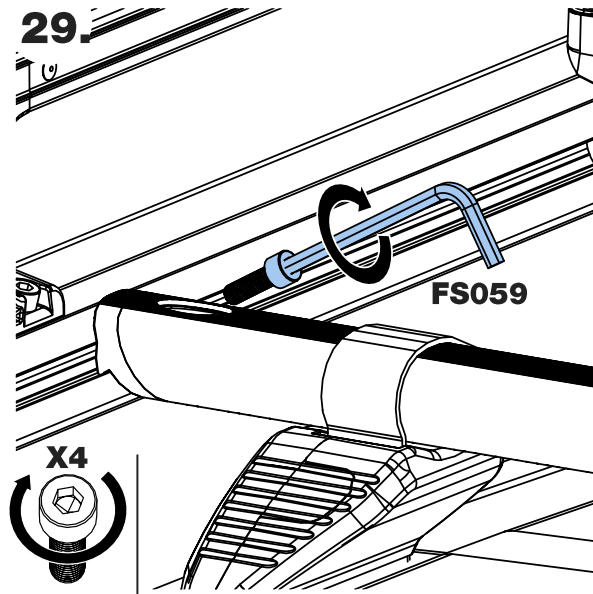

30.

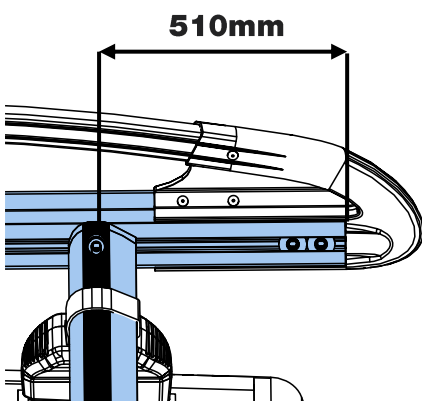

31.

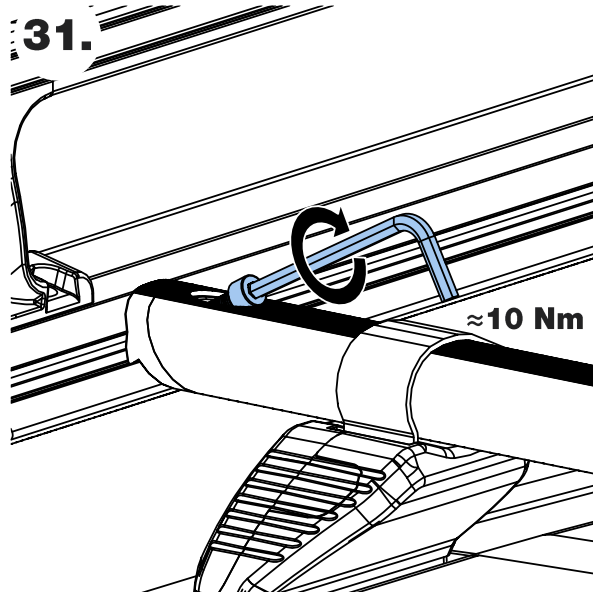

32.

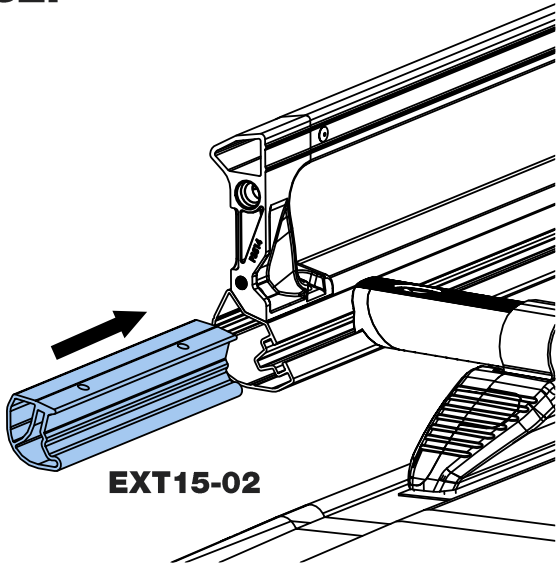

33.

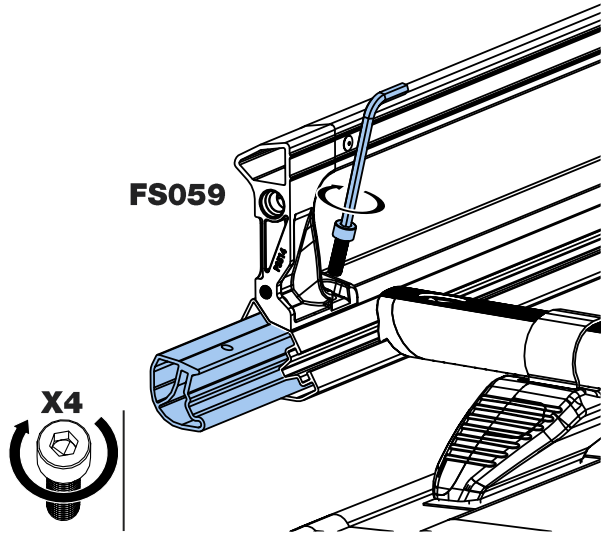

34.

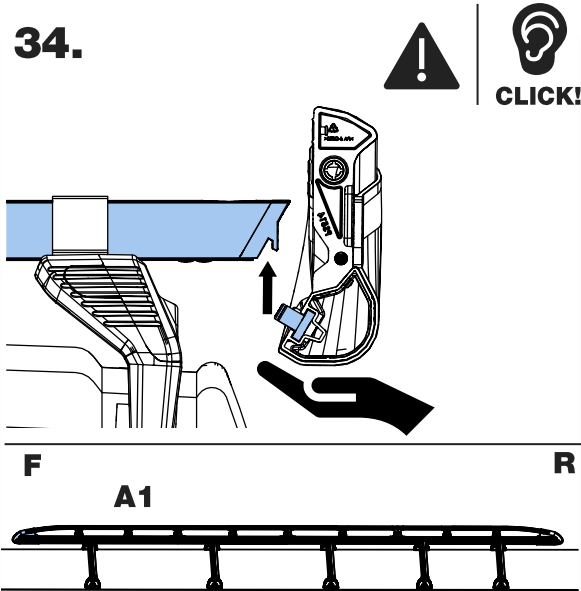

35.

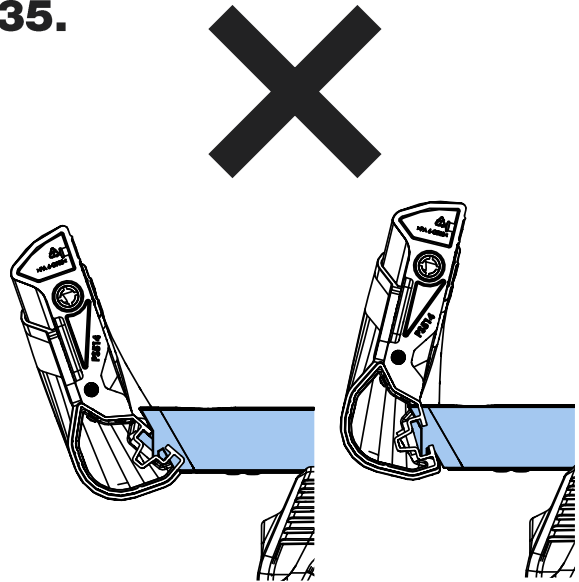

36.

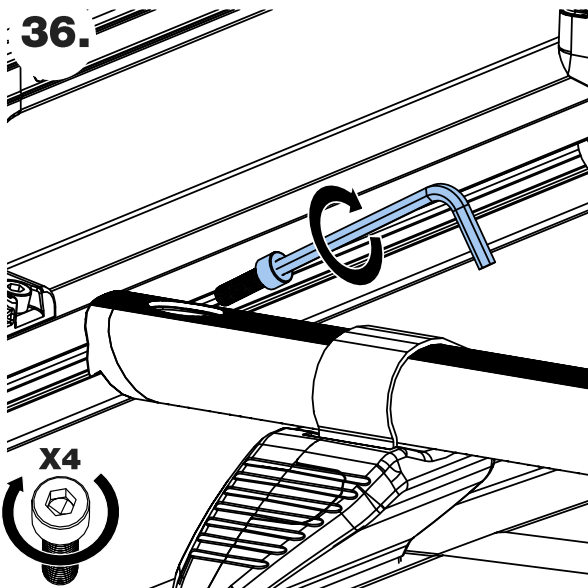

37.

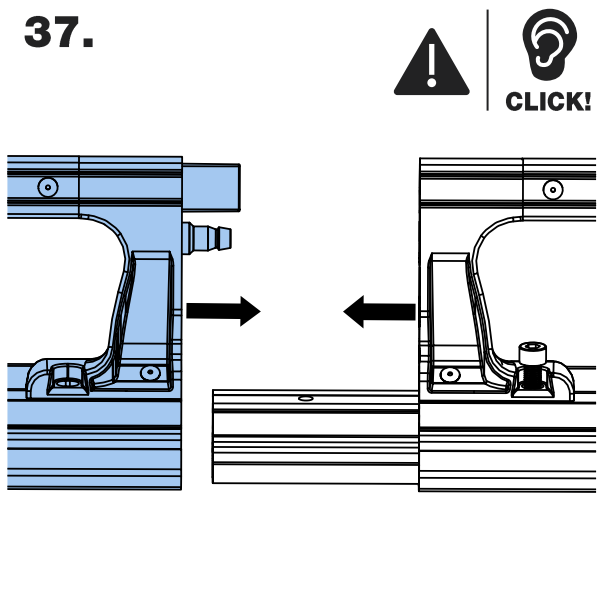

38.

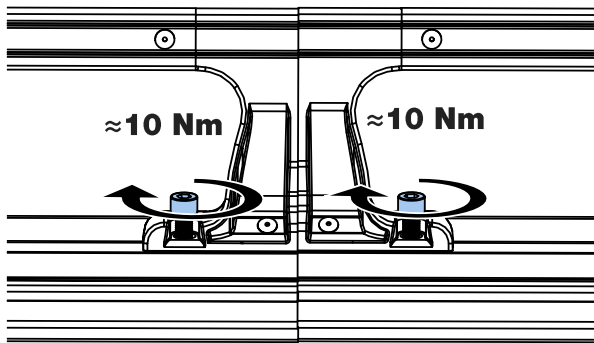

39.

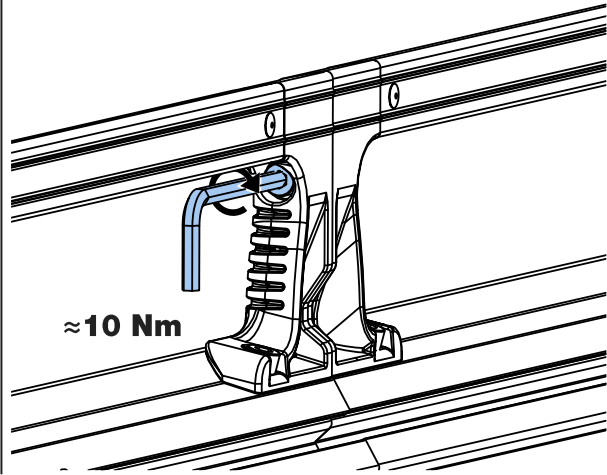

40.

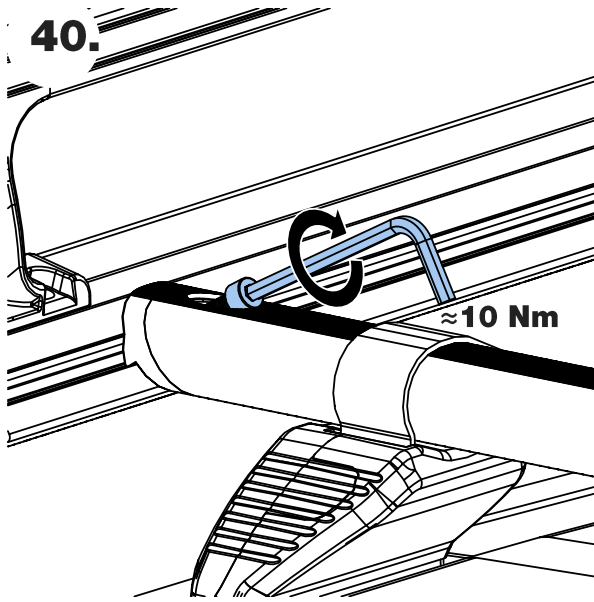

41.

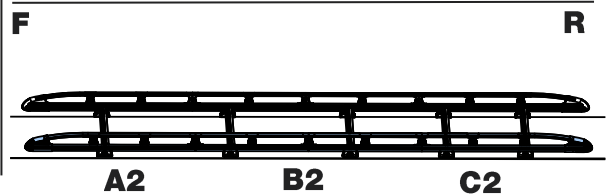
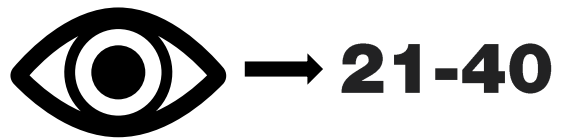

42.

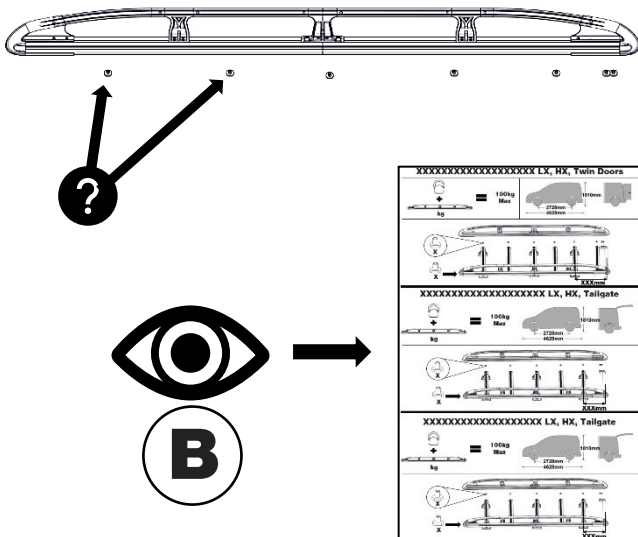

43.

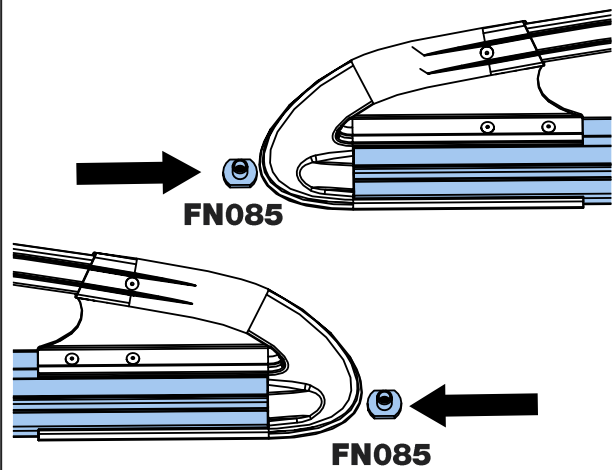

44.

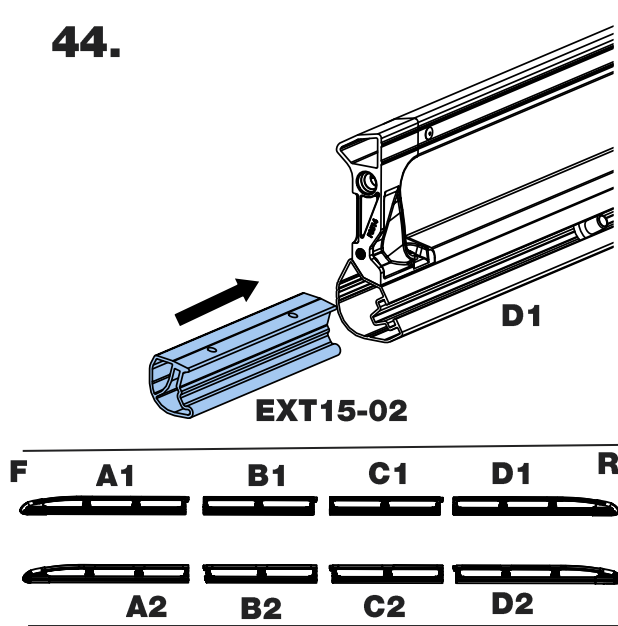

45.

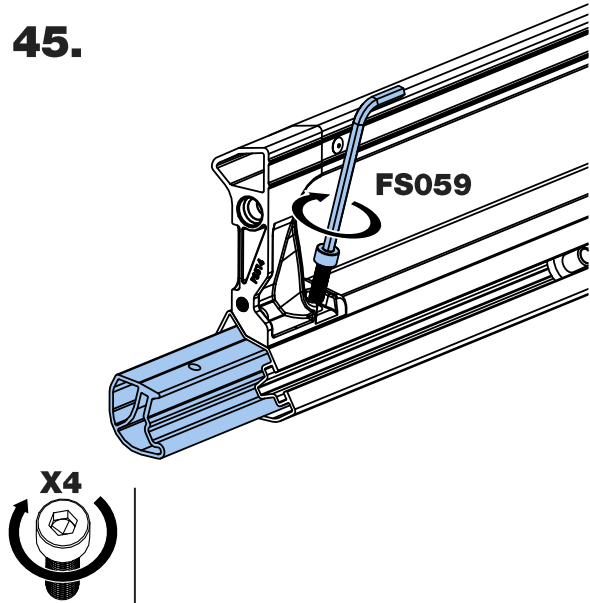

46.

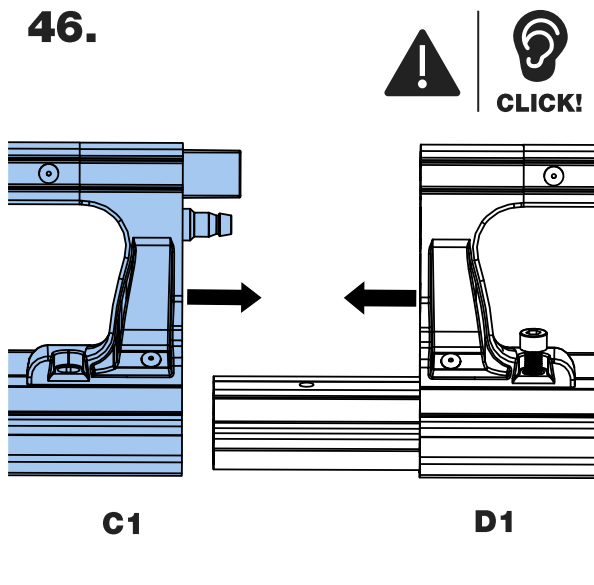

47.

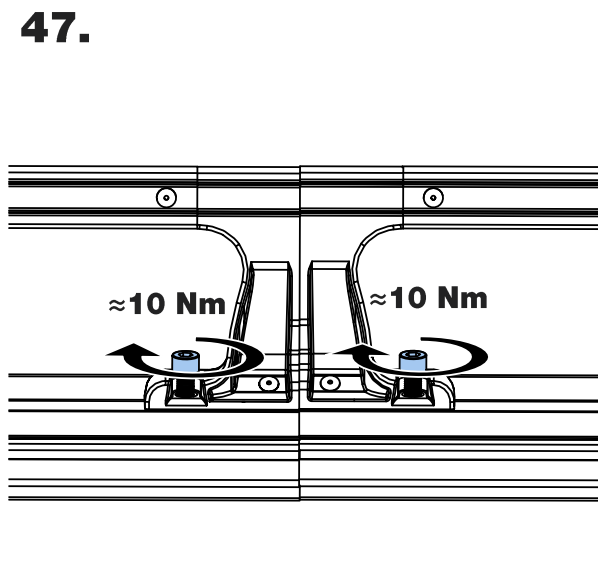

48.

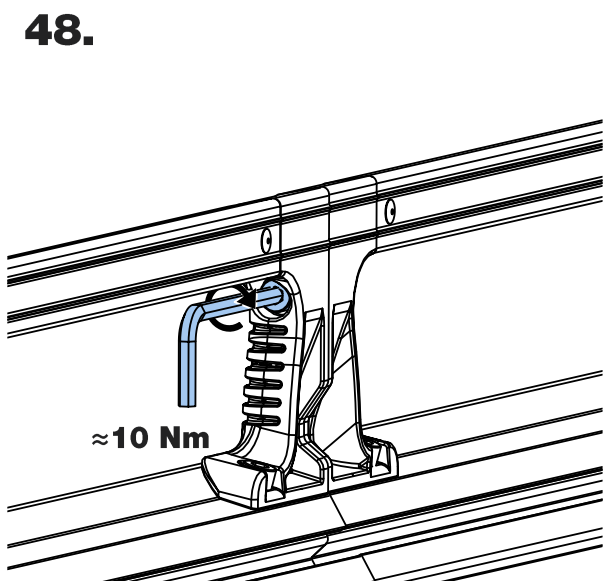

49.

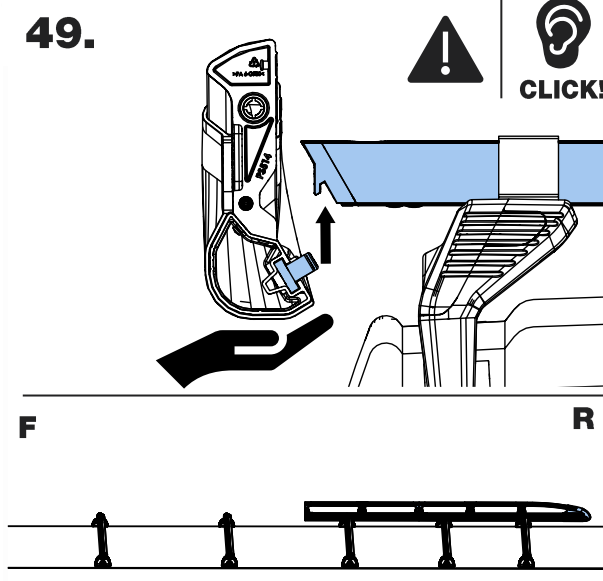

50.

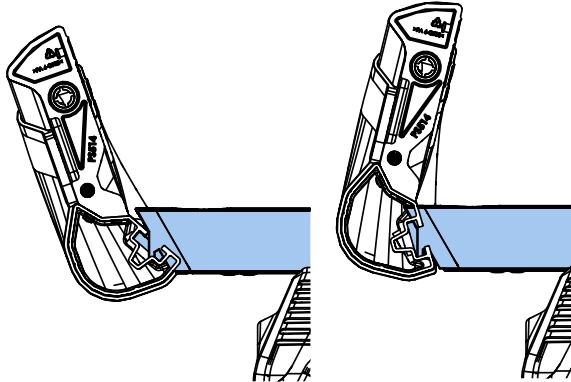

51.

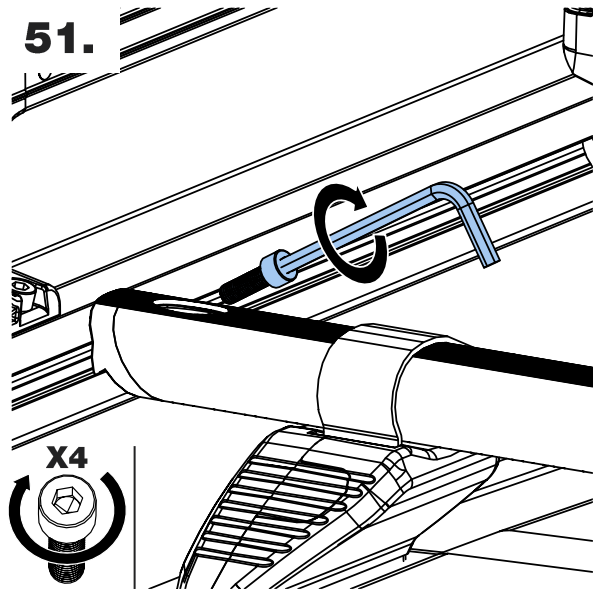

52.

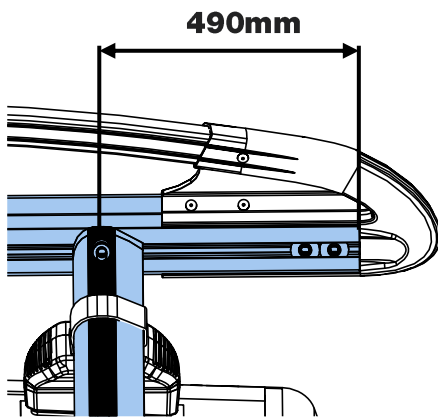

53.

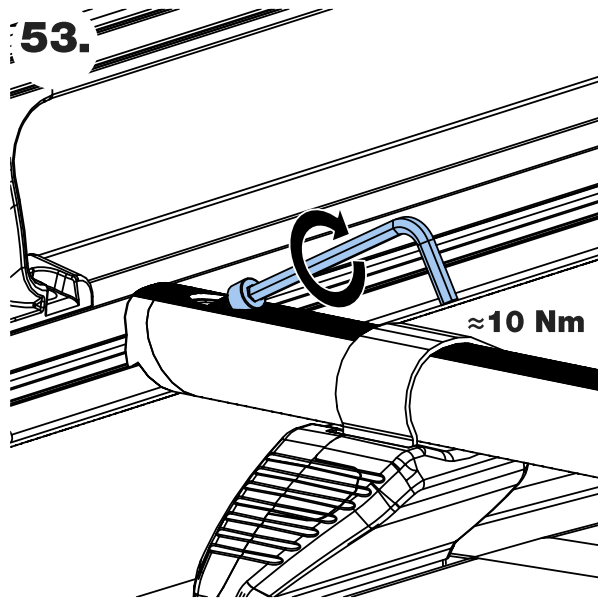

54.

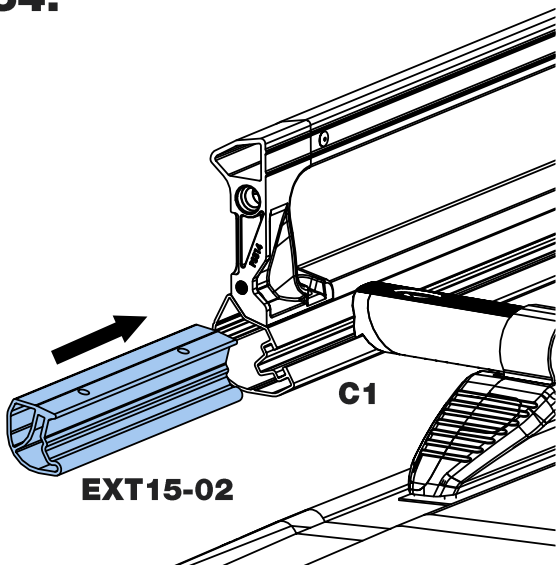

55.

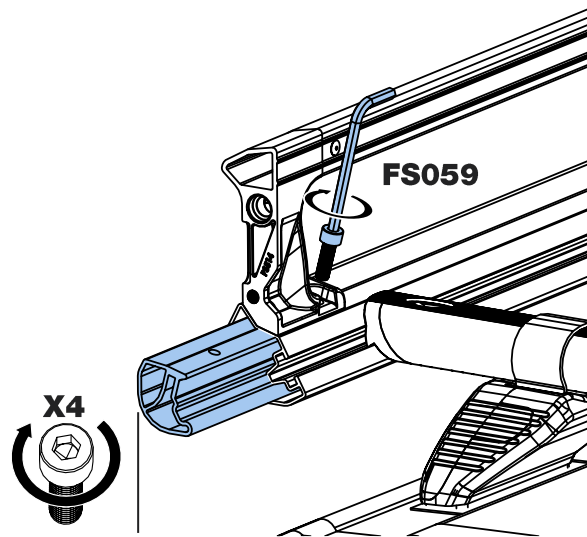

56.

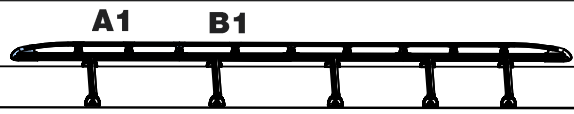
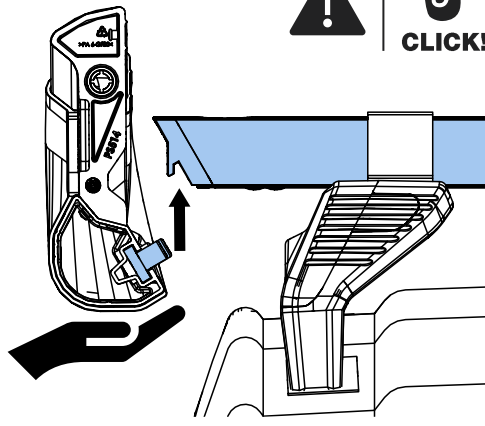

57.

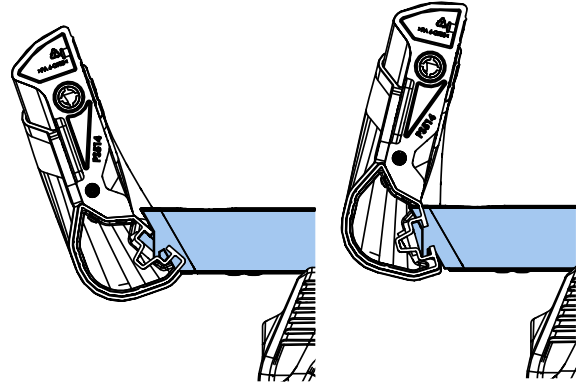

58.

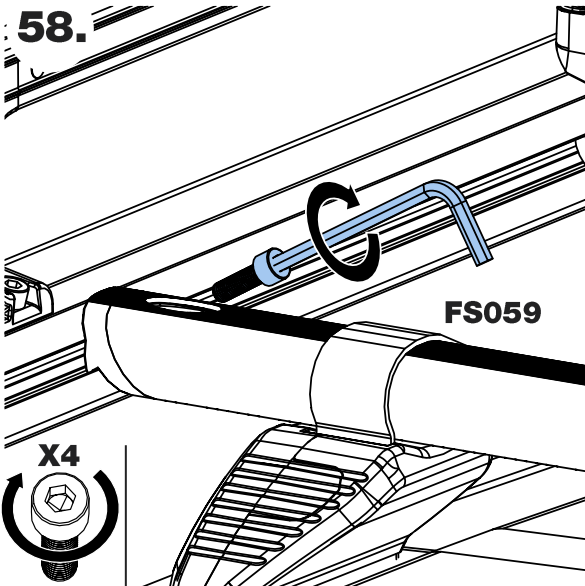

59.

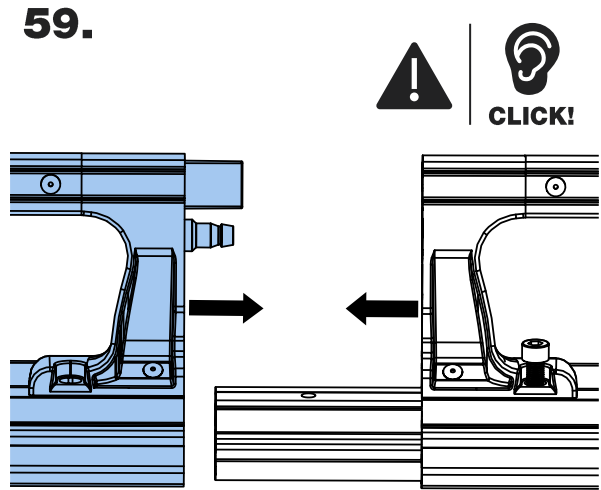

60.

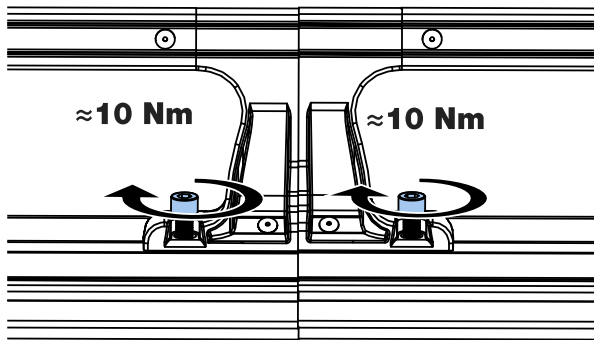

61.

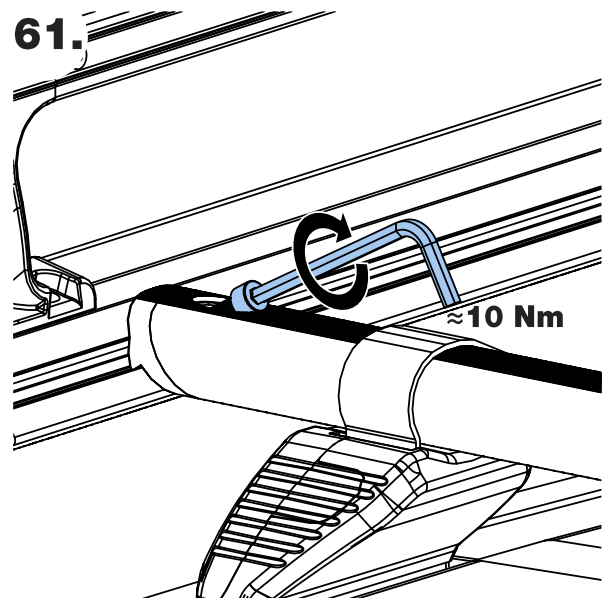

62.

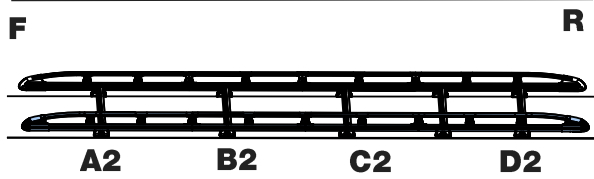
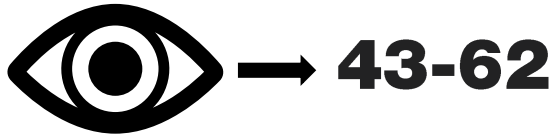

63.

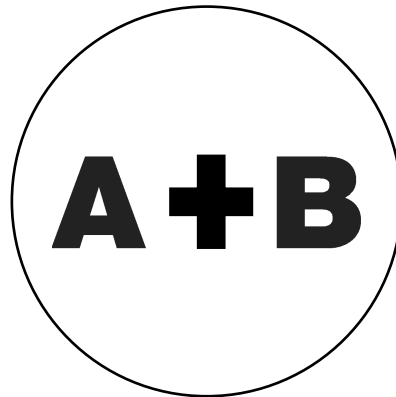

64.

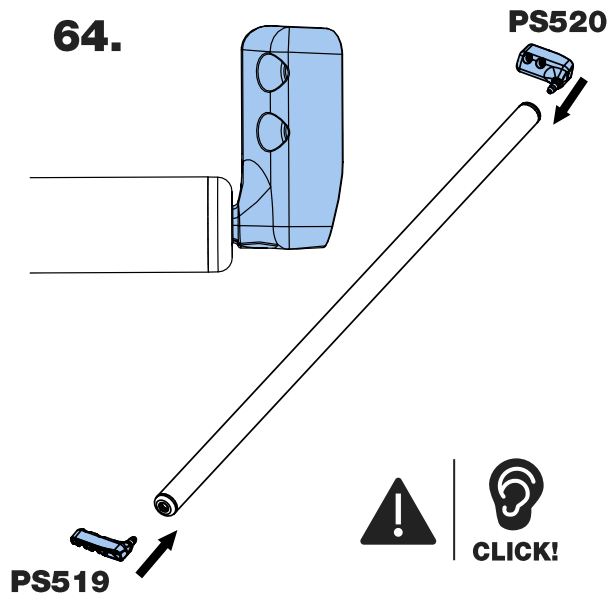

65.

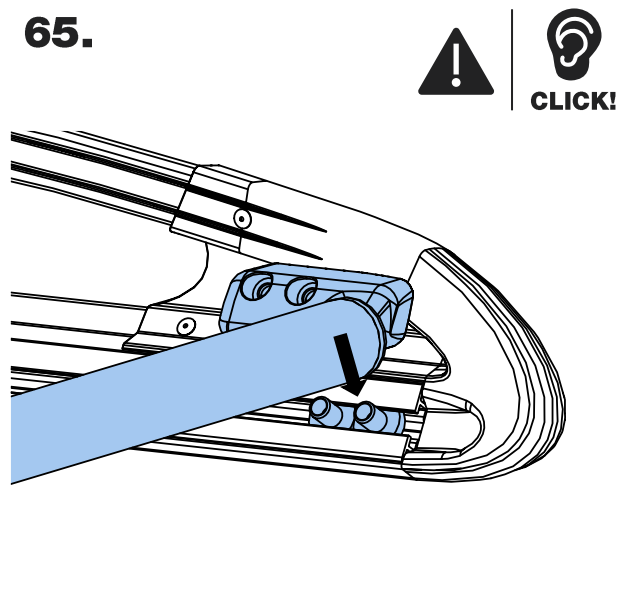

66.

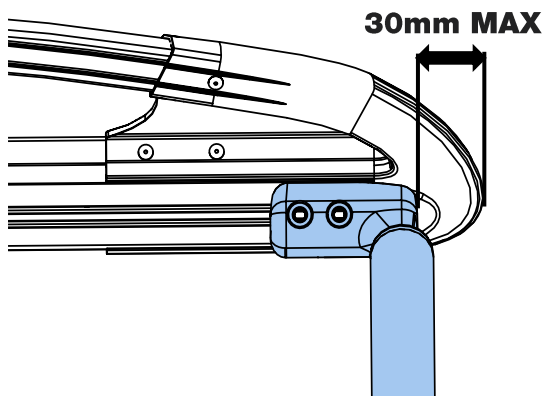

67.

